



BRITISH
STEEL

Product Range

BUILDING STRONGER FUTURES

WELCOME TO BRITISH STEEL

British Steel is one of Europe's leading steel manufacturers, producing around 3 million tonnes of quality steel products every year. We supply high-quality rail, sections, special profiles, wire rod and a variety of semi-finished products for some of the most demanding applications around the world.

In March 2020, we were bought by distinguished Chinese multi-industrial company Jingye Group, beginning a new chapter in British steelmaking.

Our steelworks have existed for around 150 years and we're excited about what we can collectively achieve to build a successful future for many years to come.

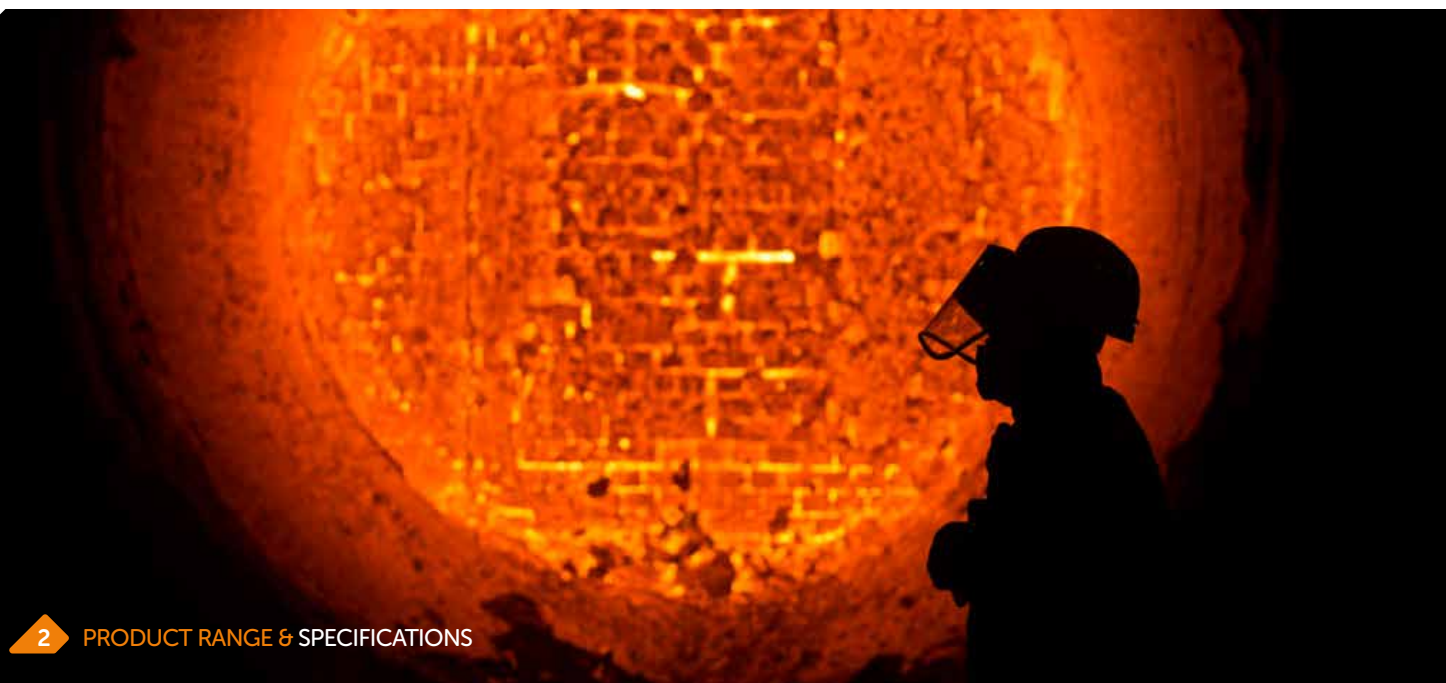

Our operations

We have a range of operations across the UK and Europe, supported by an international chain of sales offices.

Our steel is produced in Scunthorpe via the basic oxygen steelmaking (BOS) route. Our mills take this carefully made steel and roll it into a range of products that we supply across the world.

- STEELMAKING
- MANUFACTURING
- SERVICE CENTRE
- R&D FACILITIES



| Location | Semi-finished products | Sections | Special profiles | Wire rod | Rail | Services |
|--------------|------------------------|----------|------------------|----------|------|--|
| Scunthorpe | ● | ● | | ● | ● | |
| Teesside | | ● | | | | Processing, cutting, shotblasting and painting |
| Skinningrove | | | ● | | | |
| Darlington | | | ● | | | Cutting, shotblasting, drilling and notching |
| Lisburn | | | | | | Processing, cutting, shotblasting and painting |
| Alblasserdam | | | | ● | | Wire drawing, annealing and pickling |

THE MARKETS WE SERVE

Our wide range of products, manufactured to internationally recognised standards, are used in many markets and demanding applications, helping share the modern world we see around us every day.

Our steel has helped build some of the world's most iconic and awe-inspiring projects, including:

- The Shard, London
- Crossrail, London
- Petronas Towers, Kuala Lumpur
- Camlica Tower, Istanbul
- Yankees Stadium, New York
- Harmony of the Seas cruise ship

Automotive



Construction



Energy & Power



Construction & Earthmoving Equipment



Defence & Security



Photo courtesy of Andrew Linnett/MOD

Rail Infrastructure



Consumer Goods



CONTENTS

| | | |
|----------|---|------------|
| 1 | SPECIAL PROFILES | 6 |
| 1.1 | Bulb flats | 8 |
| 1.2 | Condumax® cathode bars | 16 |
| 1.3 | Crane rail | 20 |
| 1.4 | Cutting edge | 24 |
| 1.5 | Forklift profiles | 30 |
| 1.6 | Tophat | 34 |
| 1.7 | Trackshoe profiles | 40 |
| 1.8 | Melting Base Iron (MBI) | 46 |
| 2 | WIRE ROD | 48 |
| 2.1 | Cold heading | 50 |
| 2.2 | Freecutting | 53 |
| 2.3 | Tyre reinforcement | 56 |
| 2.4 | Automotive spring steel | 58 |
| 2.5 | Rail clip | 60 |
| 2.6 | Bearing steel | 62 |
| 2.7 | Welding steel | 65 |
| 2.8 | High tensile | 68 |
| 2.9 | PC strand | 70 |
| 2.10 | Wire Processing Centre | 72 |
| 3 | CONSTRUCTION | 75 |
| 3.1 | UK sections | 77 |
| | • Universal beams | 78 |
| | • Universal columns | 81 |
| | • Universal bearing piles | 83 |
| | • Parallel flange channels | 84 |
| | • Asymmetric beams | 85 |
| | • Unequal angles | 85 |
| | • Equal angles | 86 |
| 3.2 | American sections | 88 |
| | • American wide flange beams (W) | 89 |
| | • American wide flange bearing piles (HP) | 94 |
| 3.3 | European sections | 95 |
| | • European I beams (IPE) | 96 |
| | • European wide flange beams (HE) | 97 |
| 3.4 | Advance® sections | 99 |
| 3.5 | S460M structural sections | 101 |
| 3.6 | Weathering steel structural sections | 103 |
| 3.7 | Service centres and distribution facilities | 106 |
| 4 | RAIL | 108 |
| 4.1 | Rail profiles and grades | 110 |
| 4.2 | HP range | 113 |
| 4.3 | Zinoco® coated rail | 115 |
| 4.4 | Steel sleepers | 117 |
| 5 | SEMI-FINISHED PRODUCTS | 119 |
| 5.1 | Slabs | 121 |
| 5.2 | Blooms | 124 |
| 5.3 | Billets | 127 |
| 6 | CONTACTS | 130 |



1 SPECIAL PROFILES

ABOUT SPECIAL PROFILES

Our Special Profiles mill is located in Skinningrove in the north east of England; from here we are able to deliver all around the world.

We provide unique steel solutions for unique applications; our extensive range of special profiles is used to make components for a wide range of industries from shipbuilding to construction and earthmoving equipment; material handling to mining.

Whether its building a ship, manufacturing earthmoving equipment or designing a mine shaft, our technical and roll design teams are on hand to work with you to create the optimum profile shape for your application.

We can roll profiles up to 260kg/metre – from simple profiles with non-standard dimensions, to highly complex and asymmetrical shapes. We supply both ‘reserved’ profiles designed for individual customer needs and ‘open’ roll profiles which are available to all customers. Through establishing long-term relationships with our customers we are able to help them develop and modify the profile ranges they require.

We also offer additional processing including cold sawing to exact length, shot blasting, painting and a range of fabrication and machining operations to meet our customers’ requirements.



1.1 BULB FLATS



1.1 BULB FLATS

Light weight corrosion resistant solution for plate stiffening

Bulb flats are the most cost-effective, efficient and corrosion-resistant solution for plate stiffening. They provide an excellent strength to weight ratio delivering buckling resistance at a lower weight than flat bars or angles.

We supply bulb flats in a wide range of steel types and grades. We also offer a choice of finishing services to meet our customers' needs. These include:

- Shot blasting and priming – to provide improved fabrication performance and protection
- Weld edge preparation to reduce preparation required for automated welding
- A range of enhanced dimensional tolerances giving further weight and engineering enhancements to your designs

Our flexible and regular rolling programme of all our products means we can help our customers achieve closer project schedule adherence.

We are ISO 9001 and ISO 14001 compliant. We also have approval of the world's leading classification societies including: ABS, BV, CCS, DNV, GL, LRS, RINA and MRRS.

Steel types and grades

Shipbuilding steels

| Strength | Grade | |
|---------------|-------|---|
| Normal | A, B | ● |
| | D | ● |
| | E | ● |
| High strength | A32 | ● |
| | D32 | ● |
| | A36 | ● |
| | D36 | ● |
| | E36 | ● |

Grades that are held in bloom stock, readily available to roll in the next available capacity ●

The following grades are within our capability and steel is made to order ●

Other grades may also be available upon request.

Structural steels

| Euronorm | Grade | |
|-----------|-----------|---|
| ASTM | A572 Gr50 | ● |
| | S235JR+AR | ● |
| | S235J0+AR | ● |
| EN10025-2 | S235J2+AR | ● |
| | S275JR+AR | ● |
| | S275J0+AR | ● |
| | S275J2+AR | ● |
| | S355JR+AR | ● |
| EN10025-4 | S355J0+AR | ● |
| | S355J2+AR | ● |
| | S355M | ● |
| EN10225 | G11 | ● |
| | G12 | ● |

1.1 BULB FLATS

Dimensions

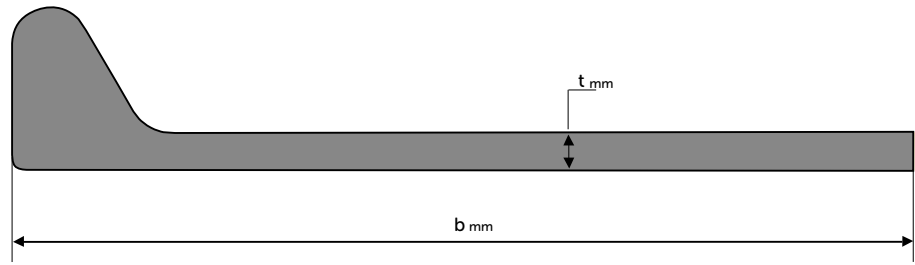

| | |
|-------------------|---------|
| Width, b (mm) | 160-430 |
| Thickness, t (mm) | 7-20 |
| Length (m) | 6-16.5* |

* short cuts and longer lengths up to 18m available on request

Dimensional tolerances

Width

| Width b, (mm) | EN10067 Standard | Special 1 | Special 2 |
|---------------------|---------------------|--------------------|----------------------|
| $\geq 160 \leq 180$ | $\pm 2.0\text{mm}$ | $\pm 2.0\text{mm}$ | $\pm 1.5 \text{ mm}$ |
| $\geq 180 \leq 300$ | $\pm 3.0\text{mm}$ | $\pm 2.2\text{mm}$ | $\pm 1.7 \text{ mm}$ |
| $\geq 300 \leq 430$ | $\pm 4.00\text{mm}$ | $\pm 3.0\text{mm}$ | $\pm 2.0 \text{ mm}$ |

Our special width tolerances are achieved through an offline 100% weld edge grinding process.

This ensures clean flat edges for superior welding.

Thickness

Thickness **t** tolerances for different widths ranges.

| Width b, (mm) | EN10067 Standard | Special 1 |
|---------------------|------------------|----------------|
| $\geq 160 \leq 180$ | -0.3 / +1.0mm | -0.2 / + 0.6mm |
| $> 180 \leq 300$ | -0.4/ + 1.0mm | -0.3 / + 0.6mm |
| $> 300 \leq 430$ | -0.4/ + 1.2mm | -0.3 / + 0.6mm |

Length

Closer tolerances may be achieved by special agreement.

| Length, L | EN10067 Standard |
|-----------|------------------|
| All | -0 / + 100 mm |

Individual lengths between 6m and 16.5m are available as a standard stackable length. Lengths outside this range (1.5m to 18m) may be available on request on a limited tonnage basis.

1.1 BULB FLATS

Straightness – bow and camber

As measured over the length of the bar.

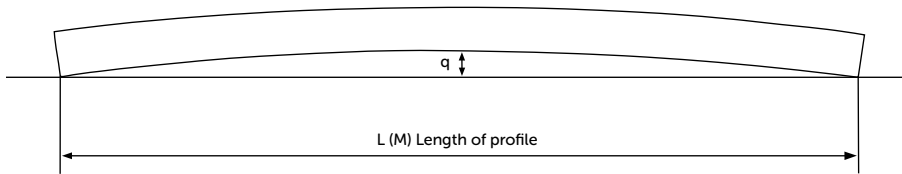

| Length | EN10067 Standard | Special 1 | Special 2 |
|---------------------|--------------------------|--------------------------|---------------------------|
| $L \leq 18\text{m}$ | $q \leq 0.0035 \times L$ | $q \leq 0.0025 \times L$ | $q \leq 0.00125 \times L$ |

Twist

The permissible degree of twist is given as the following:

| Length | Standard | Special 1 |
|--------|----------|-----------|
| All | 0.5°/m | 0.35°/m |

Twist can be difficult to measure and is easiest to measure converted into Torsion by measuring the Torsion **T** in mm and applying the following calculations:

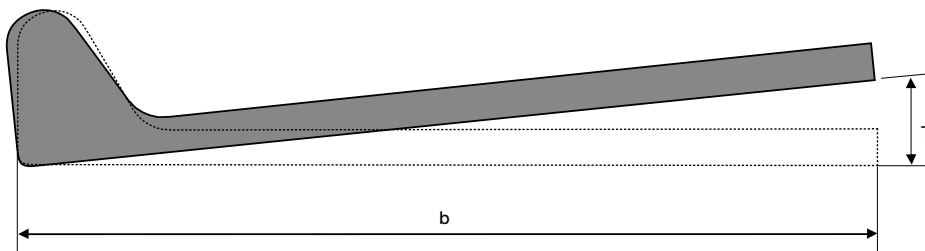

Torsion, T (mm) = width (mm) x sin tol degree, x length (M)

Torsion: $T = b \times \sin 0.35^\circ \times L$ - Special steel 1

Torsion: $T = b \times \sin 0.5^\circ \times L$ - Standard steel

| Length, L | 6m | | 10m | | 12m | | 15m | | 18m | |
|-----------------|-----------------|-------|-------|-------|-------|-------|-------|-------|-------|-------|
| Permitted twist | 0.35° | 0.5° | 0.35° | 0.5° | 0.35° | 0.5° | 0.35° | 0.5° | 0.35° | 0.5° |
| Width, b (mm) | Torsion, T (mm) | | | | | | | | | |
| 160 | 5.86 | 8.38 | 9.77 | 13.96 | 11.73 | 16.75 | 14.66 | 20.94 | 17.59 | 25.13 |
| 180 | 6.60 | 9.42 | 11.00 | 15.71 | 13.19 | 18.85 | 16.49 | 23.56 | 19.79 | 28.27 |
| 200 | 7.33 | 10.47 | 12.22 | 17.45 | 14.66 | 20.94 | 18.33 | 26.18 | 21.99 | 31.42 |
| 220 | 8.06 | 11.52 | 13.44 | 19.20 | 16.13 | 23.04 | 20.16 | 28.80 | 24.19 | 34.56 |
| 240 | 8.80 | 12.57 | 14.66 | 20.94 | 17.59 | 25.13 | 21.99 | 31.42 | 26.39 | 37.70 |
| 260 | 9.53 | 13.61 | 15.88 | 22.69 | 19.06 | 27.23 | 23.82 | 34.03 | 28.59 | 40.84 |
| 280 | 10.26 | 14.66 | 17.10 | 24.43 | 20.52 | 29.32 | 25.66 | 36.65 | 30.79 | 43.98 |
| 300 | 11.00 | 15.71 | 18.33 | 26.18 | 21.99 | 31.42 | 27.49 | 39.27 | 32.99 | 47.12 |
| 320 | 11.73 | 16.75 | 19.55 | 27.92 | 23.46 | 33.51 | 29.32 | 41.89 | 35.19 | 50.26 |
| 340 | 12.46 | 17.80 | 20.77 | 29.67 | 24.92 | 35.60 | 31.15 | 44.51 | 37.38 | 53.41 |
| 370 | 13.56 | 19.37 | 22.60 | 32.29 | 27.12 | 38.75 | 33.90 | 48.43 | 40.68 | 58.12 |
| 400 | 14.66 | 20.94 | 24.43 | 34.91 | 29.32 | 41.89 | 36.65 | 52.36 | 43.98 | 62.83 |
| 430 | 15.76 | 22.51 | 26.27 | 37.52 | 31.52 | 45.03 | 39.40 | 56.29 | 47.28 | 67.54 |

1.1 BULB FLATS

Flatness

The plate flatness tolerance h is 0.3% of the bulb flat width b and is measured as shown below.

Plate flatness tolerance: $h \leq 0.003 \times b$

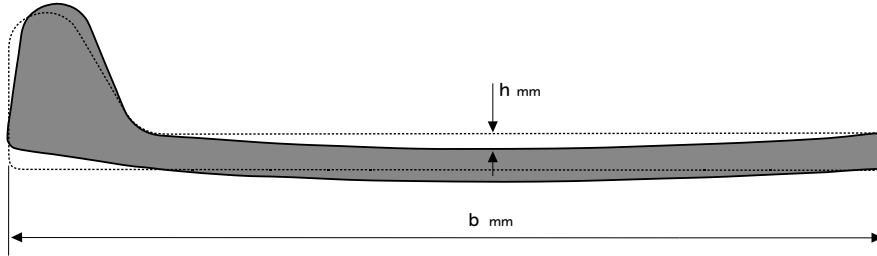

The bulb flatness tolerance of the heel is n measured as shown below with a 2mm maximum.

Bulb flatness tolerance: $n \leq 2.0 \text{ mm}$



Shape

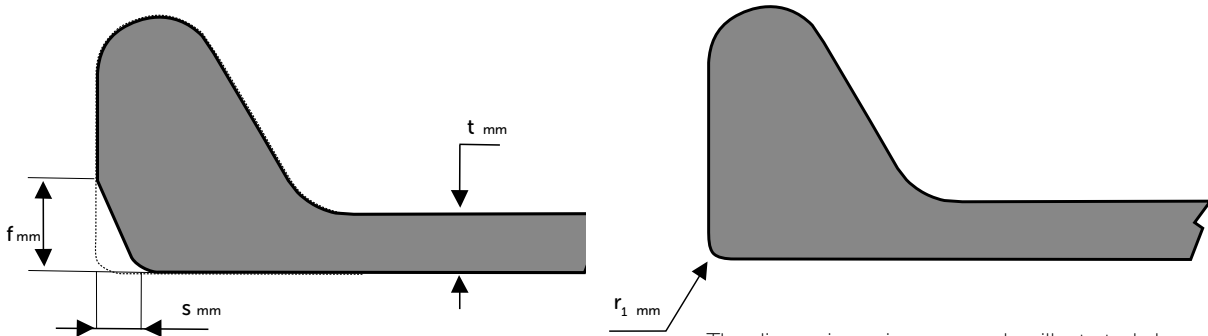

The dimensions s and f are measured as illustrated above.

The dimension r_1 is measured as illustrated above.

Bulb head corner tolerances s

| Thickness | Tolerance |
|----------------------------|-------------------------|
| $t \leq 9 \text{ mm}$ | $s \leq 2.0 \text{ mm}$ |
| $9 < t \leq 13 \text{ mm}$ | $s \leq 3.0 \text{ mm}$ |
| $t > 13 \text{ mm}$ | $s \leq 4.0 \text{ mm}$ |

Bulb head corner tolerances f

| Thickness | Tolerance |
|--------------------|-----------------|
| $t > 7 \text{ mm}$ | $f \leq 0.75 S$ |

Bulb head corner tolerances radius r_1

Radius of curvature of corners r_1 for thickness

| Thickness | $r_1 \leq$ |
|---------------------|------------|
| $5 < t \leq 9$ | 2.0mm |
| $9 \leq t < 13$ | 3.0mm |
| $13 \leq t \leq 20$ | 4.0mm |

1.1 BULB FLATS

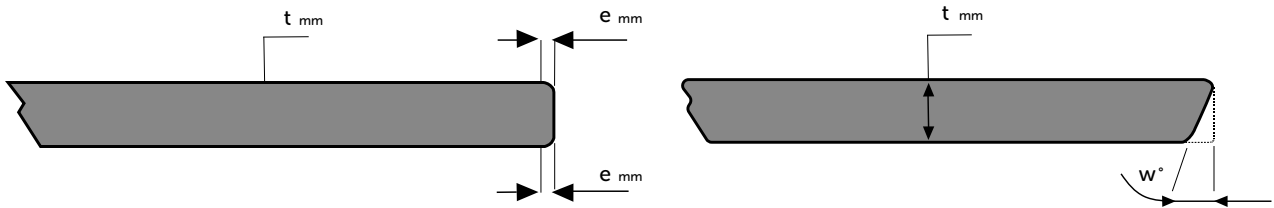

The dimension **e** is measured as illustrated above.

The dimension **w** is measured as illustrated above.

Web edge tolerances **e**

| Thickness | EN10067 - Standard |
|--------------------|--------------------|
| $t \leq 9$ mm | $e \leq 2.0$ mm |
| $9 < t \leq 13$ mm | $e \leq 3.0$ mm |
| $t > 13$ mm | $e \leq 4.0$ mm |

Tighter tolerances may be available on request through grinding of the web edge.

Web edge tolerances angle **w**

| Thickness | Tolerance |
|--------------------|------------------|
| $t \leq 9$ mm | $w \leq 4^\circ$ |
| $9 < t \leq 13$ mm | $w \leq 4^\circ$ |
| $t > 13$ mm | $w \leq 4^\circ$ |

Tighter tolerance on web edge tolerance **e** and angle **w** may be available on request through offline grinding of the web edge.

Surface condition

The surface requirements and repair conditions for shipbuilding profiles are in accordance with EN10163-3:2004, subclass 3, class C. Maximum permissible depth of discontinuities and grinding allowance below minimum specified thickness are given in the table below:

| Nominal thickness of the Product, t | Maximum permissible depth of discontinuities (mm) |
|-------------------------------------|---|
| $3 \leq t < 6$ | 20% of t |
| $6 \leq t < 20$ | 1.2 |
| $20 \leq t < 40$ | 1.7 |

1.1 BULB FLATS

Dimensions and properties

| Section description | Dimensions | | | | | Mass per metre G Kg/m | Area of section A cm ² | Surface area per metre U m ² /m | Distance to centre of gravity | |
|---------------------|------------|---------|---------|---------|---------|-----------------------------|---|--|-------------------------------|----------|
| | b mm | t mm | c mm | d mm | r mm | | | | dx mm | dy mm |
| 160x7 | 160 | 7.0 | 22.0 | 22.2 | 6.0 | 11.46 | 14.58 | 0.365 | 96.7 | 6.5 |
| 160x8 | 160 | 8.0 | 22.0 | 22.2 | 6.0 | 12.72 | 16.18 | 0.367 | 95.1 | 6.8 |
| 160x9 | 160 | 9.0 | 22.0 | 22.2 | 6.0 | 13.97 | 17.78 | 0.370 | 93.7 | 7.1 |
| 160x10 | 160 | 10.0 | 22.0 | 22.2 | 6.0 | 15.30 | 19.34 | 0.371 | 92.6 | 7.5 |
| 160x11 | 160 | 11.0 | 22.0 | 22.2 | 6.0 | 16.49 | 20.94 | 0.373 | 91.7 | 7.9 |
| 160x11.5 | 160 | 11.5 | 22.0 | 22.2 | 6.0 | 17.30 | 21.74 | 0.374 | 91.3 | 8.1 |
| 180x8 | 180 | 8.0 | 25.0 | 25.5 | 7.0 | 14.80 | 18.83 | 0.412 | 109.0 | 7.4 |
| 180x9 | 180 | 9.0 | 25.0 | 25.5 | 7.0 | 16.22 | 20.63 | 0.414 | 107.4 | 7.7 |
| 180x10 | 180 | 10.0 | 25.0 | 25.5 | 7.0 | 17.63 | 22.40 | 0.416 | 106.0 | 8.1 |
| 180x11 | 180 | 11.0 | 25.0 | 25.5 | 7.0 | 19.04 | 24.20 | 0.418 | 104.8 | 8.4 |
| 180x11.5 | 180 | 11.5 | 25.0 | 25.5 | 7.0 | 19.70 | 25.10 | 0.419 | 104.3 | 8.6 |
| 200x8.5 | 200 | 8.5 | 28.0 | 28.8 | 8.0 | 17.80 | 22.63 | 0.458 | 122.2 | 8.2 |
| 200x9 | 200 | 9.0 | 28.0 | 28.8 | 8.0 | 18.57 | 23.63 | 0.459 | 121.3 | 8.4 |
| 200x10 | 200 | 10.0 | 28.0 | 28.8 | 8.0 | 20.14 | 25.60 | 0.460 | 119.7 | 8.7 |
| 200x11 | 200 | 11.0 | 28.0 | 28.8 | 8.0 | 21.71 | 27.60 | 0.463 | 118.3 | 9.0 |
| 200x11.5 | 200 | 11.5 | 28.0 | 28.8 | 8.0 | 22.50 | 28.60 | 0.464 | 117.6 | 9.2 |
| 200x12 | 200 | 12.0 | 28.0 | 28.8 | 8.0 | 23.28 | 29.60 | 0.465 | 117.0 | 9.4 |
| 220x9 | 220 | 9.0 | 31.0 | 32.1 | 9.0 | 21.00 | 26.78 | 0.504 | 135.5 | 9.1 |
| 220x10 | 220 | 10.0 | 31.0 | 32.1 | 9.0 | 22.77 | 28.94 | 0.505 | 133.7 | 9.3 |
| 220x11 | 220 | 11.0 | 31.0 | 32.1 | 9.0 | 24.50 | 31.14 | 0.507 | 132.0 | 9.7 |
| 220x11.5 | 220 | 11.5 | 31.0 | 32.1 | 9.0 | 25.30 | 32.24 | 0.509 | 131.2 | 9.8 |
| 220x12 | 220 | 12.0 | 31.0 | 32.1 | 9.0 | 26.22 | 33.34 | 0.510 | 130.5 | 10.0 |
| 230x11 | 230 | 11.0 | 32.5 | 33.75 | 9.5 | 25.06 | 32.97 | 0.530 | 138.9 | 10.0 |
| 240x9.5 | 240 | 9.5 | 34.0 | 35.4 | 10.0 | 24.40 | 31.23 | 0.549 | 148.9 | 9.9 |
| 240x10 | 240 | 10.0 | 34.0 | 35.4 | 10.0 | 25.50 | 32.43 | 0.550 | 147.9 | 10.0 |
| 240x10.5 | 240 | 10.5 | 34.0 | 35.4 | 10.0 | 26.40 | 33.63 | 0.551 | 146.9 | 10.2 |
| 240x11 | 240 | 11.0 | 34.0 | 35.4 | 10.0 | 27.39 | 34.83 | 0.552 | 145.9 | 10.3 |
| 240x11.5 | 240 | 11.5 | 34.0 | 35.4 | 10.0 | 28.30 | 36.03 | 0.554 | 145.1 | 10.5 |
| 240x12 | 240 | 12.0 | 34.0 | 35.4 | 10.0 | 29.27 | 37.23 | 0.555 | 144.3 | 10.6 |
| 260x10 | 260 | 10.0 | 37.0 | 38.7 | 11.0 | 28.35 | 36.05 | 0.595 | 162.3 | 10.7 |
| 260x11 | 260 | 11.0 | 37.0 | 38.7 | 11.0 | 30.39 | 38.65 | 0.597 | 160.1 | 11.0 |
| 260x12 | 260 | 12.0 | 37.0 | 38.7 | 11.0 | 32.43 | 41.25 | 0.600 | 158.2 | 11.3 |
| 260x13 | 260 | 13.0 | 37.0 | 38.7 | 11.0 | 34.40 | 43.85 | 0.602 | 156.5 | 11.6 |
| 280x10.5 | 280 | 10.5 | 40.0 | 42.0 | 12.0 | 32.40 | 41.22 | 0.641 | 175.7 | 11.6 |
| 280x11 | 280 | 11.0 | 40.0 | 42.0 | 12.0 | 33.50 | 42.62 | 0.642 | 174.5 | 11.7 |
| 280x12 | 280 | 12.0 | 40.0 | 42.0 | 12.0 | 35.70 | 45.42 | 0.645 | 172.4 | 11.9 |
| 280x13 | 280 | 13.0 | 40.0 | 42.0 | 12.0 | 37.90 | 48.22 | 0.647 | 170.5 | 12.2 |
| 300x11 | 300 | 11.0 | 43.0 | 45.3 | 13.0 | 36.70 | 46.73 | 0.687 | 189.1 | 12.4 |
| 300x12 | 300 | 12.0 | 43.0 | 45.3 | 13.0 | 39.09 | 49.73 | 0.690 | 186.7 | 12.7 |
| 300x13 | 300 | 13.0 | 43.0 | 45.3 | 13.0 | 41.44 | 52.73 | 0.692 | 184.6 | 12.9 |
| 320x11.5 | 320 | 11.5 | 46.0 | 48.6 | 14.0 | 41.20 | 52.59 | 0.733 | 202.5 | 13.3 |
| 320x12 | 320 | 12.0 | 46.0 | 48.6 | 14.0 | 42.60 | 54.19 | 0.735 | 201.3 | 13.4 |
| 320x12.5 | 320 | 12.5 | 46.0 | 48.6 | 14.0 | 43.80 | 55.79 | 0.736 | 200.1 | 13.5 |
| 320x13 | 320 | 13.0 | 46.0 | 48.6 | 14.0 | 45.09 | 57.39 | 0.737 | 199.0 | 13.6 |
| 320x13.5 | 320 | 13.5 | 46.0 | 48.6 | 14.0 | 46.30 | 58.94 | 0.737 | 198.0 | 13.7 |
| 320x14 | 320 | 14.0 | 46.0 | 48.6 | 14.0 | 47.60 | 60.54 | 0.738 | 197.0 | 13.9 |
| 340x12 | 340 | 12.0 | 49.0 | 52.0 | 15.0 | 46.20 | 58.78 | 0.780 | 216.0 | 14.1 |
| 340x12.5 | 340 | 12.5 | 49.0 | 52.0 | 15.0 | 47.50 | 60.48 | 0.781 | 214.7 | 14.2 |
| 340x13 | 340 | 13.0 | 49.0 | 52.0 | 15.0 | 48.86 | 62.18 | 0.782 | 213.5 | 14.3 |
| 340x14 | 340 | 14.0 | 49.0 | 52.0 | 15.0 | 51.50 | 65.54 | 0.784 | 211.3 | 14.6 |
| 340x15 | 340 | 15.0 | 49.0 | 52.0 | 15.0 | 54.20 | 68.94 | 0.786 | 209.2 | 14.8 |
| 370x12.5 | 370 | 12.5 | 53.5 | 56.9 | 16.5 | 53.10 | 67.79 | 0.848 | 236.9 | 15.4 |
| 370x13 | 370 | 13.0 | 53.5 | 56.9 | 16.5 | 54.70 | 69.64 | 0.850 | 235.5 | 15.5 |
| 370x14 | 370 | 14.0 | 53.5 | 56.9 | 16.5 | 57.60 | 73.30 | 0.851 | 233.0 | 15.7 |
| 370x15 | 370 | 15.0 | 53.5 | 56.9 | 16.5 | 60.50 | 77.00 | 0.854 | 230.7 | 15.9 |
| 370x16 | 370 | 16.0 | 53.5 | 56.9 | 16.5 | 63.50 | 80.70 | 0.857 | 228.6 | 16.1 |
| 400x13 | 400 | 13.0 | 58.0 | 61.9 | 18.0 | 60.80 | 77.43 | 0.918 | 257.9 | 16.6 |
| 400x14 | 400 | 14.0 | 58.0 | 61.9 | 18.0 | 63.96 | 81.38 | 0.919 | 255.1 | 16.8 |
| 400x15 | 400 | 15.0 | 58.0 | 61.9 | 18.0 | 67.10 | 85.38 | 0.922 | 252.5 | 17.0 |
| 400x16 | 400 | 16.0 | 58.0 | 61.9 | 18.0 | 70.20 | 89.38 | 0.925 | 250.2 | 17.2 |
| 430x14 | 430 | 14.0 | 62.5 | 66.8 | 19.5 | 70.60 | 89.78 | 0.987 | 277.5 | 18.0 |
| 430x15 | 430 | 15.0 | 62.5 | 66.8 | 19.5 | 73.90 | 94.08 | 0.990 | 274.6 | 18.1 |
| 430x17 | 430 | 17.0 | 62.5 | 66.8 | 19.5 | 80.70 | 102.68 | 0.995 | 269.6 | 18.5 |
| 430x18 | 430 | 18.0 | 62.5 | 66.8 | 19.5 | 83.90 | 106.98 | 0.998 | 267.4 | 18.8 |
| 430x19 | 430 | 19.0 | 62.5 | 66.8 | 19.5 | 87.40 | 111.28 | 1.001 | 265.4 | 19.0 |
| 430x20 | 430 | 20.0 | 62.5 | 66.8 | 19.5 | 90.80 | 115.58 | 1.004 | 263.5 | 19.3 |

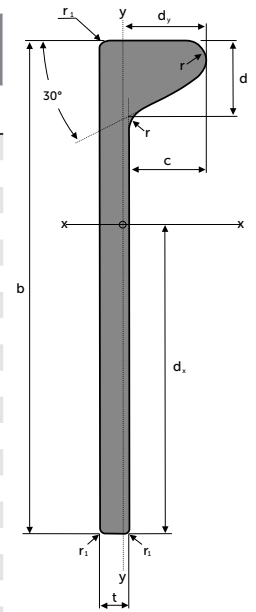

1.1 BULB FLATS

Dimensions and properties (continued)

| Section description | Second moment of inertia | | Elastic modulus | | Radius of gyration | | Warping constant | Torsional constant |
|---------------------|--------------------------|--------------------------|--------------------------|--------------------------|--------------------|-------------|---|------------------------|
| | I_x cm ⁴ | I_y cm ⁴ | Z_x cm ³ | Z_y cm ³ | r_x cm | r_y cm | Z_y cm ⁶ /10 ³ | J cm ⁴ |
| 160x7 | 37110 | 5.85 | 38.4 | 9.0 | 5.05 | 0.63 | 111 | 3.65 |
| 160x8 | 409.27 | 6.54 | 43.0 | 9.7 | 5.03 | 0.64 | 115 | 4.57 |
| 160x9 | 446.70 | 7.31 | 47.7 | 10.3 | 5.01 | 0.64 | 119 | 5.73 |
| 160x10 | 481.31 | 8.15 | 52.0 | 10.9 | 4.99 | 0.65 | 122 | 7.12 |
| 160x11 | 517.81 | 9.09 | 56.5 | 11.5 | 4.97 | 0.66 | 126 | 8.86 |
| 160x11.5 | 535.93 | 9.60 | 58.7 | 11.9 | 4.96 | 0.66 | 129 | 9.85 |
| 180x8 | 606.55 | 9.89 | 55.6 | 13.3 | 5.67 | 0.72 | 2.41 | 6.24 |
| 180x9 | 661.09 | 10.92 | 61.6 | 14.1 | 5.66 | 0.73 | 2.47 | 7.57 |
| 180x10 | 711.72 | 12.03 | 67.1 | 14.9 | 5.64 | 0.73 | 2.52 | 9.15 |
| 180x11 | 764.60 | 13.25 | 72.9 | 15.7 | 5.62 | 0.74 | 2.60 | 11.13 |
| 180x11.5 | 790.81 | 13.90 | 75.8 | 16.1 | 5.61 | 0.74 | 2.64 | 12.26 |
| 200x8.5 | 901.07 | 15.06 | 73.7 | 18.3 | 6.31 | 0.82 | 4.71 | 9.20 |
| 200x9 | 939.14 | 15.75 | 77.4 | 18.8 | 6.30 | 0.82 | 4.76 | 10.00 |
| 200x10 | 1010.47 | 17.18 | 84.4 | 19.8 | 6.28 | 0.82 | 4.83 | 11.78 |
| 200x11 | 1084.33 | 18.75 | 91.7 | 20.8 | 6.27 | 0.82 | 4.95 | 14.01 |
| 200x11.5 | 1120.89 | 19.57 | 95.3 | 21.3 | 6.26 | 0.83 | 5.02 | 15.28 |
| 200x12 | 1157.23 | 20.43 | 98.9 | 21.8 | 6.25 | 0.83 | 5.09 | 16.65 |
| 220x9 | 1290.48 | 22.01 | 95.2 | 24.3 | 6.94 | 0.91 | 8.61 | 13.17 |
| 220x10 | 1387.89 | 23.86 | 103.8 | 25.5 | 6.92 | 0.91 | 8.72 | 15.16 |
| 220x11 | 1488.07 | 25.83 | 112.7 | 26.8 | 6.91 | 0.91 | 8.90 | 17.65 |
| 220x11.5 | 1537.57 | 26.87 | 117.2 | 27.4 | 6.91 | 0.91 | 8.99 | 19.06 |
| 220x12 | 1586.73 | 27.94 | 121.6 | 28.0 | 6.90 | 0.92 | 9.10 | 20.60 |
| 230x11 | 1724.98 | 30.05 | 124.2 | 30.1 | 7.23 | 0.95 | 11.69 | 19.81 |
| 240x9.5 | 1787.40 | 31.12 | 120.0 | 31.4 | 7.57 | 1.00 | 14.83 | 18.25 |
| 240x10 | 1854.67 | 32.30 | 125.4 | 32.2 | 7.56 | 1.00 | 14.94 | 19.46 |
| 240x10.5 | 1921.25 | 33.52 | 130.8 | 33.0 | 7.56 | 1.00 | 15.06 | 20.78 |
| 240x11 | 1987.20 | 34.78 | 136.2 | 33.8 | 7.55 | 1.00 | 15.19 | 22.22 |
| 240x11.5 | 2052.60 | 36.06 | 141.5 | 34.5 | 7.55 | 1.00 | 15.33 | 23.79 |
| 240x12 | 2117.50 | 37.39 | 146.8 | 35.2 | 7.54 | 1.00 | 15.48 | 25.49 |
| 260x10 | 2421.72 | 42.80 | 149.2 | 39.9 | 8.20 | 1.09 | 24.54 | 24.85 |
| 260x11 | 2593.45 | 45.86 | 162.0 | 41.8 | 8.19 | 1.09 | 24.87 | 27.91 |
| 260x12 | 2762.00 | 49.07 | 174.6 | 43.6 | 8.18 | 1.09 | 25.25 | 31.50 |
| 260x13 | 2927.94 | 52.45 | 187.0 | 45.3 | 8.17 | 1.09 | 25.69 | 35.69 |
| 280x10.5 | 3210.10 | 57.50 | 182.7 | 49.7 | 8.82 | 1.18 | 39.05 | 33.16 |
| 280x11 | 3318.79 | 59.39 | 190.2 | 50.8 | 8.82 | 1.18 | 39.27 | 34.90 |
| 280x12 | 3532.99 | 63.29 | 205.0 | 53.0 | 8.82 | 1.18 | 39.77 | 38.84 |
| 280x13 | 3743.56 | 67.37 | 219.6 | 55.1 | 8.81 | 1.18 | 40.34 | 43.42 |
| 300x11 | 4175.43 | 75.68 | 220.8 | 60.9 | 9.45 | 1.27 | 60.10 | 43.42 |
| 300x12 | 4443.49 | 80.39 | 238.0 | 63.5 | 9.45 | 1.27 | 60.72 | 47.73 |
| 300x13 | 4706.64 | 85.27 | 254.9 | 66.1 | 9.45 | 1.27 | 61.45 | 52.71 |
| 320x11.5 | 5342.16 | 97.86 | 263.8 | 73.7 | 10.08 | 1.36 | 89.86 | 55.95 |
| 320x12 | 5506.76 | 100.69 | 273.6 | 75.3 | 10.08 | 1.36 | 90.25 | 58.38 |
| 320x12.5 | 5669.75 | 103.58 | 283.4 | 76.8 | 10.08 | 1.36 | 90.68 | 60.99 |
| 320x13 | 5831.26 | 106.51 | 293.1 | 78.3 | 10.08 | 1.36 | 91.15 | 63.79 |
| 320x13.5 | 5977.59 | 109.44 | 301.9 | 79.7 | 10.07 | 1.36 | 91.35 | 66.51 |
| 320x14 | 6136.58 | 112.48 | 311.5 | 81.1 | 10.07 | 1.36 | 91.89 | 69.71 |
| 340x12 | 6736.30 | 124.57 | 311.9 | 88.2 | 10.70 | 1.46 | 131.02 | 71.06 |
| 340x12.5 | 6934.97 | 127.98 | 323.1 | 89.9 | 10.71 | 1.45 | 131.53 | 73.88 |
| 340x13 | 7131.73 | 131.44 | 334.1 | 91.7 | 10.71 | 1.45 | 132.09 | 76.91 |
| 340x14 | 7504.42 | 138.47 | 355.2 | 95.0 | 10.70 | 1.45 | 132.97 | 83.29 |
| 340x15 | 7886.99 | 145.80 | 377.0 | 98.3 | 10.70 | 1.45 | 134.41 | 90.88 |
| 370x12.5 | 9184.55 | 172.23 | 387.8 | 112.1 | 11.64 | 1.59 | 221.07 | 97.62 |
| 370x13 | 9444.05 | 176.62 | 401.0 | 114.2 | 11.64 | 1.59 | 221.76 | 101.01 |
| 370x14 | 9936.79 | 185.49 | 426.5 | 118.5 | 11.64 | 1.59 | 222.83 | 108.11 |
| 370x15 | 10440.07 | 194.68 | 452.5 | 122.6 | 11.64 | 1.59 | 224.72 | 116.55 |
| 370x16 | 10935.90 | 204.14 | 478.4 | 126.6 | 11.64 | 1.59 | 226.88 | 126.04 |
| 400x13 | 12234.74 | 232.34 | 474.5 | 139.7 | 12.57 | 1.73 | 357.80 | 131.25 |
| 400x14 | 12872.91 | 243.41 | 504.7 | 145.0 | 12.58 | 1.73 | 358.96 | 139.13 |
| 400x15 | 13521.89 | 254.79 | 535.5 | 150.1 | 12.58 | 1.73 | 361.32 | 148.48 |
| 400x16 | 14160.53 | 266.45 | 566.1 | 154.9 | 12.59 | 1.73 | 364.08 | 158.97 |
| 430x14 | 16366.61 | 313.68 | 589.9 | 174.7 | 13.50 | 1.87 | 559.02 | 177.41 |
| 430x15 | 17189.22 | 327.65 | 626.0 | 180.8 | 13.52 | 1.87 | 561.76 | 187.72 |
| 430x17 | 18794.22 | 356.44 | 697.1 | 192.5 | 13.53 | 1.86 | 569.01 | 212.09 |
| 430x18 | 19579.84 | 371.35 | 732.2 | 197.9 | 13.53 | 1.86 | 573.41 | 226.30 |
| 430x19 | 20355.95 | 386.65 | 767.0 | 203.4 | 13.52 | 1.86 | 578.26 | 241.98 |
| 430x20 | 21123.62 | 402.40 | 801.6 | 208.6 | 13.52 | 1.87 | 583.53 | 259.20 |

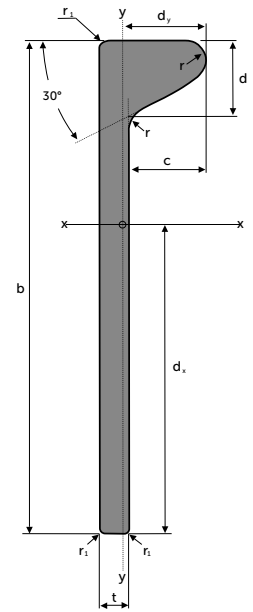

1.2 CONDUMAX[®] CATHODE BARS



1.2 CONDUMAX® CATHODE BARS

Helping our customers improve their energy performance

We work with primary aluminium smelters to offer high quality cathode collector bars for use in aluminium production.

Condumax cathode bars have a unique chemical composition of 0.01% carbon, significantly lower than the 0.04-0.06% carbon content present in other commercially available cathode collector bars.

Our quality steelmaking practices ensure tight control of chemistry giving consistency of carbon and other trace elements between bars for predictable performance

Our unique chemistry offers significant benefits:

- Up to 40% lower resistivity than mild steel cathode bars
- 10% lower measured electrical resistivity in production trial vs. competitors' ultra-low resistivity cathode bars
- Longer service life and lower energy use in service
- 60 tonne reduction of CO₂ emissions per pot over the lifetime of the pot

Certification is in accordance with EN 10204 Type 3.1 analysis only.

Condumax steel grade

The tables below indicate the chemical analysis units and mechanical properties for British Steel's Condumax grade.

Chemical composition

| Maximum | C (%) | Si (%) | Mn (%) | S (%) | P (%) | Cr (%) | Mo (%) | Nb (%) | V (%) | Ni (%) | B (%) | Al (%) |
|----------|-------|--------|--------|-------|-------|--------|--------|--------|-------|--------|--------|--------|
| Condumax | 0.01 | 0.01 | 0.20 | 0.015 | 0.02 | 0.05 | 0.02 | 0.01 | 0.015 | 0.07 | 0.0008 | 0.02 |

1.2 CONDUMAX CATHODE BARS

Dimensions and properties

Size range and production tolerances

Our standard product sizes are in the following range:

| | |
|---------------|--------------|
| Width (W) | 122 to 279mm |
| Thickness (T) | 90 to 160mm |
| Length (L) | 1.5 to 10m |

| | |
|------------|-----------|
| Bow (B) | 2mm/m max |
| Camber (C) | 2mm/m max |
| Twist | 1mm/m max |

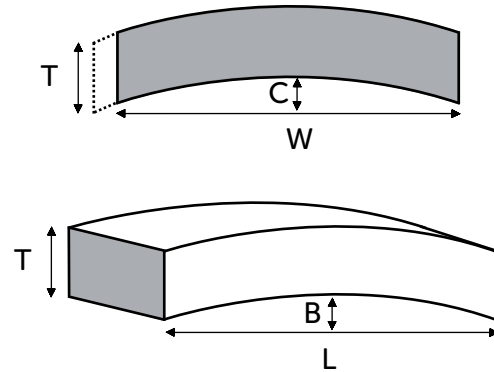
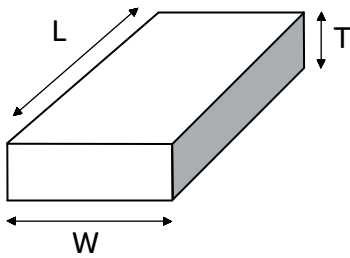

Production tolerances

| | |
|----------------------|--------------------------------------|
| Surface: | EN10163-3: 2004, Class C, Subclass 3 |
| Quantity tolerance: | ±10% based on the quantity of bars |
| Length tolerance: | -0 / +10 mm |
| Width tolerance: | +3 / -2 mm |
| Thickness tolerance: | +3 / -2 mm |

Rhomboidity



Squareness angle $\theta = 1.5^\circ$ maximum

Rhomboidity $R = T \times \tan \theta$

| T (mm) | Maximum R (mm) |
|----------|----------------|
| <100 | 3 |
| 100 <150 | 4 |
| 150 <200 | 5 |
| 200 <250 | 6 |
| 250 <300 | 7 |

Corner radius

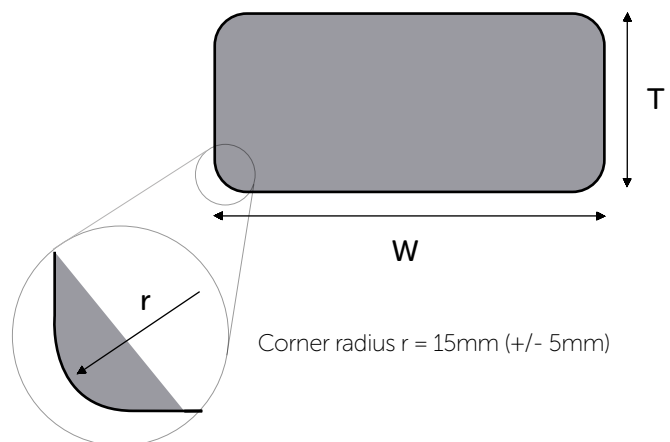

Corner radius $r = 15\text{mm} (+/- 5\text{mm})$

Alternative tolerances available upon request

1.2 CONDUMAX CATHODE BARS

Metallurgy

- British Steel's world-leading Basic Oxygen Steelmaking facilities are capable of controlling carbon and other trace elements to unrivalled levels
- Condumax (0.01% carbon cathode) operates in the ferrite α phase of the iron-carbon phase at typical operating temperatures $\sim 800^\circ\text{C}$
- Standard 0.04-0.06% low carbon cathodes operate in the ferrite / austenite 2 phase region
- Ferrite is more resistant to carbon diffusion from the graphite
- Austenite can readily hold up to 2% more carbon in the lattice than ferrite

Our Condumax will remain at the optimum ferrite phase for longer at higher temperatures, reducing carbon intake and ensuring lower resistivity for longer life.

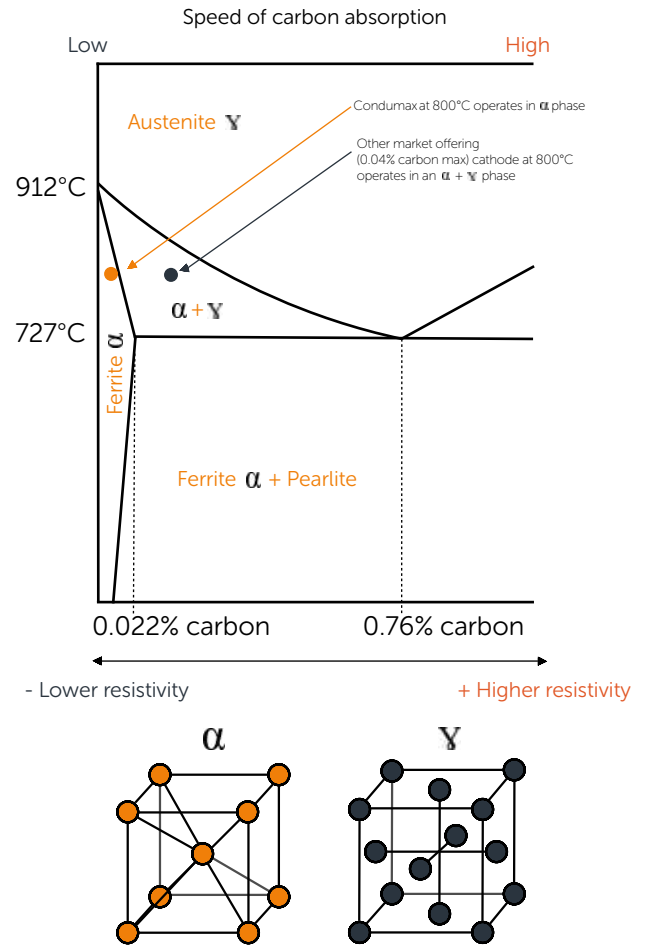

Electrical resistivity for different carbon levels

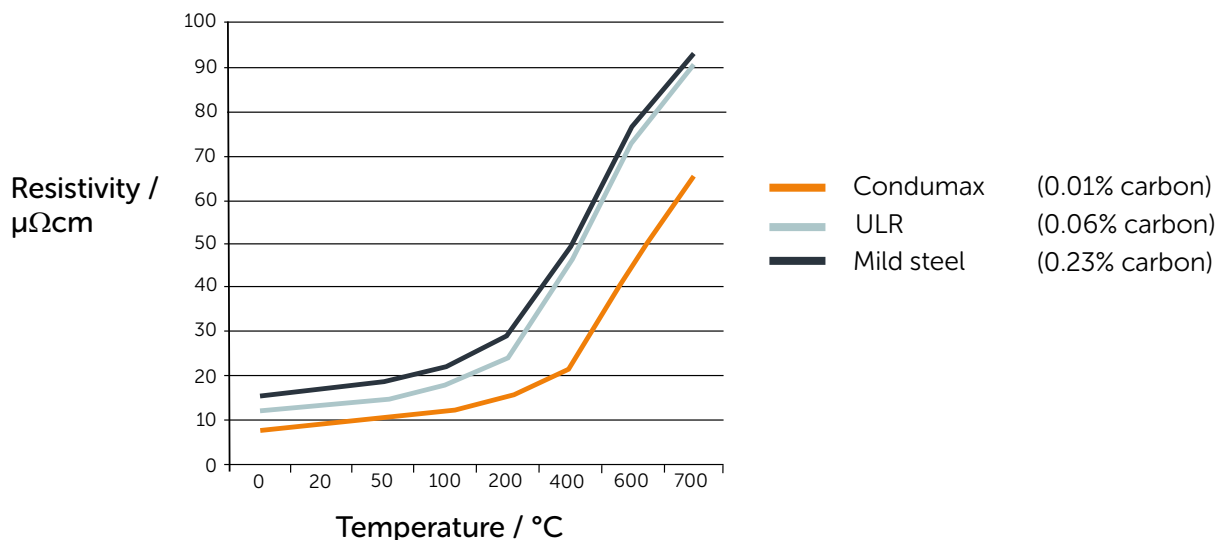

1.3 CRANE RAIL



1.3 CRANE RAIL

For use in overhead gantry and floor-mounted crane applications

Our crane rails are available in diverse strengths and sizes; we have a strong track record of supplying major projects worldwide, working alongside leading crane rail installers

What makes us different is our approach to business. The key benefits of choosing our crane rail products are:

- We build collaborative relationships - offering guidance and solutions to our customers to the benefit of their business and products
- Our steel making expertise provides the capability to offer products that can increase the crane rail's load-bearing capability and extend its life span through improved wear performance
- With a regular rolling programme of each rail size coupled with our dedicated crane rail stockholding facilities, we offer customers all over the world just-in-time delivery

As well as a full range of European crane rails, we can also produce American and special crane rails with inspection certificates issued in full accordance with EN 10204 type 3.1



1.3 CRANE RAIL

Crane rail cross section

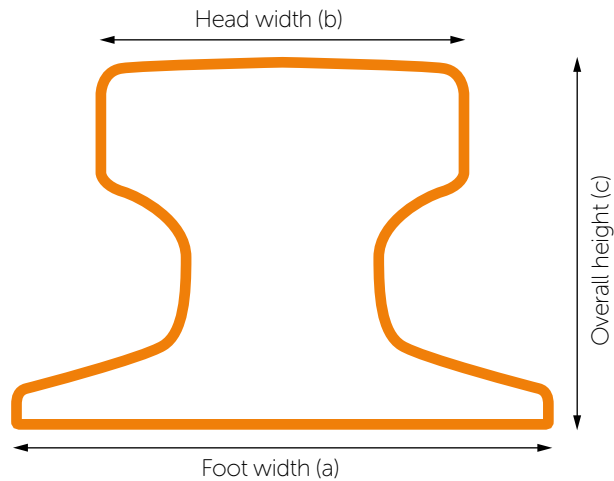

Product range

The following crane rail profiles are available and can be supplied from stock or rolled to order.

| Section | Standard | Mass per metre (kg/m) | Area of cross section (cm ²) | Foot width (a) mm | Head width (b) mm | Overall height (c) mm |
|---------|--------------------|-----------------------|--|-------------------|-------------------|-----------------------|
| A65 | DIN 536-1 | 43.1 | 54.9 | 175 | 65 | 75 |
| A75 | DIN 536-1 | 56.2 | 71.6 | 200 | 75 | 85 |
| A100 | DIN 536-1 | 74.3 | 94.7 | 200 | 100 | 95 |
| A120 | DIN 536-1 | 100.33 | 127.4 | 220 | 120 | 105 |
| A150 | DIN 536-1 | 150.3 | 191.4 | 220 | 150 | 150 |
| CR87* | British Steel spec | 86.8 | 110.5 | 152.4 | 101.6 | 152.4 |
| CR89 | British Steel spec | 89.8 | 114.4 | 178 | 102 | 114 |
| CR125 | British Steel spec | 125.15 | 159.6 | 140 | 140 | 152 |

*Also referred to as MRS87a

We also have scope to produce the American range rails including CR104, CR105, CR135, CR171 and CR175 and special rails MRS73, MRS86, MRS125, MRS192, MRS221, AS86, CR73, CR100, CRS140, JKL55, SP100 & SP120. Please contact us to discuss your requirements.

1.3 CRANE RAIL

Grade capability by size

| | DIN 536-1 | | BS | |
|----------------|-----------|-----|-----|-------|
| | 690 | 880 | 90V | 1100V |
| A65 | Yes | Yes | Yes | Yes |
| A75 | Yes | Yes | Yes | Yes |
| A100 | Yes | Yes | Yes | Yes |
| A120 | Yes | Yes | Yes | Yes |
| A150 | Yes | Yes | Yes | Yes |
| Crane rail 87 | Yes | Yes | Yes | Yes |
| Crane rail 89 | Yes | Yes | Yes | Yes |
| Crane rail 125 | Yes | Yes | Yes | Yes |

Ladle analysis

| Grade | Standard | | C | Si | Mn | P | S | V | Cr |
|--------|--------------------|-----|------|------|------|-------|-------|------|------|
| 690 | DIN 536-1 | Min | 0.40 | - | 0.80 | - | - | - | - |
| | | Max | 0.60 | 0.35 | 1.20 | 0.045 | 0.045 | - | - |
| 880 | DIN 536-1 | Min | 0.60 | - | 0.80 | - | - | - | - |
| | | Max | 0.80 | 0.50 | 1.30 | 0.045 | 0.045 | - | - |
| 90V | British Steel spec | Min | 0.50 | - | 0.80 | - | - | 0.06 | - |
| | | Max | 0.70 | 0.50 | 1.40 | 0.030 | 0.030 | 0.20 | - |
| 110CrV | British Steel spec | Min | 0.65 | 0.15 | 0.90 | - | - | 0.05 | 0.20 |
| | | Max | 0.85 | 0.30 | 1.30 | 0.030 | 0.030 | 0.15 | 0.80 |

Mechanical testing

Tensile properties are determined in accordance with EN 10002-1. The minimum strength requirements are as follows:

| Grade | Minimum yield (MPa) | Minimum UTS (MPa) | Hardness (HBN) |
|--------|---------------------|-------------------|----------------|
| 690 | 355 | 690 | 204 |
| 880 | 440 | 880 | 260 |
| 90V | 540 | 880 | 260 |
| 110CrV | 600 | 1100 | 320 |

1.4 CUTTING EDGE



1.4 CUTTING EDGE

For wear part applications

We produce a range of high-quality cutting edge profiles providing additional wear resistance and extended life for excavator bucket applications.

Customers can choose from an extensive range of 'open roll' profiles, or specify unique designs, where rolls and tooling will be reserved for individual customer use. We can produce many profile sizes and designs, including single bevels.

Our broad range of standard dimensions is produced on a dependable rolling schedule meaning all sizes are regularly available.

Our standard boron steel range:

- Offers high strength and toughness after heat treatment
- Can be used for 'weld in' applications

Our standard high carbon range:

- Offers lower tensile strength and toughness compared with the boron range
- Particularly suitable for motor grader applications



1.4 CUTTING EDGE

Product range

We offer a wide variety of single and double bevel flats as well as arrowhead and grader bar profiles suitable for a broad range of bucket edge/blade applications.

Single bevel flats

| Profile | Width mm (W) | Gauge mm (T) | Weight Kg/m | Bevel angle (A) | Bevel width mm (B) | Tip height mm (C) |
|----------|--------------|--------------|-------------|-----------------|--------------------|-------------------|
| SB244-25 | 244 | 25 | 44.46 | 22.6 | 45.60 | 6 |
| SB244-30 | 244 | 30 | 54.07 | 22.6 | 45.60 | 11 |
| SB244-32 | 244 | 32 | 57.91 | 22.6 | 45.60 | 13 |
| SB281 | 281 | 32 | 65.00 | 22.6 | 57.60 | 8 |
| SB299 | 299 | 40 | 85.25 | 22.6 | 72.00 | 10 |
| SB304 | 304 | 44.45 | 97.40 | 22.6 | 69.10 | 15.7 |

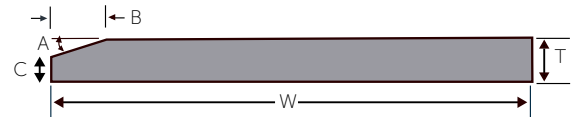

Grader bars (carbon and boron steel)

| Profile | Width mm (W) | Gauge mm (T) | Weight Kg/m | Bevel width mm (B) | Tip height mm (C) |
|----------|--------------|--------------|-------------|--------------------|-------------------|
| GB152-12 | 152.4 | 12.7 | 13.26 | 33.3 | 2.5 |
| GB152-13 | 152.4 | 13.3 | 13.98 | 33.3 | 3.1 |
| GB152-15 | 152.4 | 15.9 | 17.09 | 33.3 | 5.6 |
| GB152-19 | 152.4 | 19.1 | 20.91 | 33.3 | 8.8 |
| GB203-15 | 203.2 | 15.88 | 23.17 | 33.3 | 2.39 |
| GB203-16 | 203.2 | 16.5 | 24.14 | 33.3 | 3.01 |
| GB203-19 | 203.2 | 19.05 | 28.13 | 33.3 | 5.56 |
| GB203-25 | 203.2 | 25.4 | 38.05 | 33.3 | 11.91 |

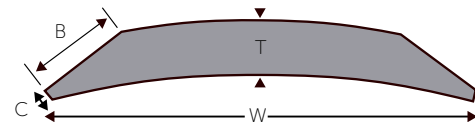

Arrowheads

| Profile | Width mm (W) | Gauge mm (T) | Weight Kg/m | Bevel angle (A) | Bevel width mm (B) | Tip height mm (C) |
|----------|--------------|--------------|-------------|-----------------|--------------------|-------------------|
| AH203-19 | 203.2 | 19.1 | 31.40 | 24.3 | 60.3 | 4.6 |
| AH203-22 | 203.2 | 22.2 | 36.50 | 24.3 | 60.3 | 7.7 |
| AH203-25 | 203.2 | 25.4 | 41.62 | 24.3 | 60.3 | 10.9 |
| AH203-28 | 203.2 | 28.6 | 46.73 | 24.3 | 60.3 | 14 |
| AH203-31 | 203.2 | 31.8 | 51.84 | 24.3 | 60.3 | 17.2 |
| AH255-28 | 255 | 28.5 | 65.65 | 25 | 98.7 | 11.2 |
| AH255-40 | 255 | 40 | 88.66 | 25 | 98.7 | 22.7 |

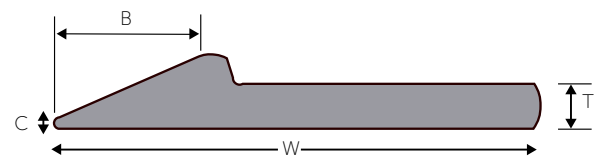

1.4 CUTTING EDGE

Double bevel flats

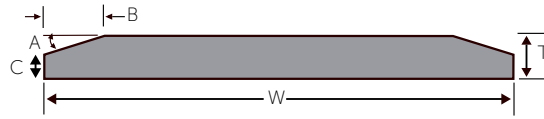

| Profile | Width mm (W) | Gauge mm (T) | Weight Kg/m | Bevel angle (A) | Bevel width mm (B) | Tip height mm (C) |
|----------|--------------|--------------|-------------|-----------------|--------------------|-------------------|
| DB203-16 | 203.2 | 16 | 23.79 | 25 | 23.60 | 5 |
| DB203-19 | 203.2 | 19 | 28.53 | 25 | 23.60 | 8 |
| DB203-22 | 203.2 | 22 | 33.28 | 25 | 23.60 | 11 |
| DB203-25 | 203.2 | 25 | 38.02 | 25 | 23.60 | 14 |
| DB203-28 | 203.2 | 28.5 | 43.55 | 25 | 23.60 | 17.5 |
| DB254-19 | 254 | 19 | 35.37 | 25 | 27.90 | 6 |
| DB254-25 | 254 | 25 | 47.25 | 25 | 27.90 | 12 |
| DB254-29 | 254 | 29 | 55.16 | 25 | 27.90 | 16 |
| DB254-32 | 254 | 32 | 61.10 | 25 | 27.90 | 19 |
| DB254-35 | 254 | 35 | 67.04 | 25 | 27.90 | 22 |
| DB254-38 | 254 | 38 | 72.97 | 25 | 27.90 | 25 |
| DB254-41 | 254 | 41 | 78.91 | 25 | 27.90 | 28 |
| DB254-45 | 254 | 45 | 86.83 | 25 | 27.90 | 32 |
| DB279-25 | 279 | 25 | 48.08 | 22.5 | 45.90 | 6 |
| DB279-35 | 279 | 35 | 70.02 | 22.5 | 45.90 | 16 |
| DB305-22 | 305 | 22 | 48.63 | 22.5 | 37.40 | 6.5 |
| DB305-25 | 305 | 25 | 55.76 | 22.5 | 37.40 | 9.5 |
| DB305-28 | 305 | 28.5 | 64.09 | 22.5 | 37.40 | 13 |
| DB305-30 | 305 | 30 | 67.66 | 22.5 | 37.40 | 14.5 |
| DB305-32 | 305 | 32 | 72.42 | 22.5 | 37.40 | 16.5 |
| DB305-35 | 305 | 35 | 79.56 | 22.5 | 37.40 | 19.5 |
| DB305-38 | 305 | 38 | 86.69 | 22.5 | 37.40 | 22.5 |
| DB305-41 | 305 | 41 | 93.83 | 22.5 | 37.40 | 25.5 |
| DB305-44 | 305 | 44.5 | 102.15 | 22.5 | 37.40 | 29 |
| DB330-19 | 330 | 19 | 45.73 | 22.5 | 32.60 | 5.5 |
| DB330-22 | 330 | 22 | 53.45 | 22.5 | 32.60 | 8.5 |
| DB330-25 | 330 | 25 | 61.18 | 22.5 | 32.60 | 11.5 |
| DB330-28 | 330 | 28.5 | 70.19 | 22.5 | 32.60 | 15 |
| DB330-30 | 330 | 30 | 74.06 | 22.5 | 32.60 | 16.5 |
| DB330-32 | 330 | 32 | 79.02 | 22.5 | 32.60 | 18.5 |

| Profile | Width mm (W) | Gauge mm (T) | Weight Kg/m | Bevel angle (A) | Bevel width mm (B) | Tip height mm (C) |
|----------|--------------|--------------|-------------|-----------------|--------------------|-------------------|
| DB330-35 | 330 | 35 | 86.93 | 22.5 | 32.60 | 21.5 |
| DB330-38 | 330 | 38 | 94.65 | 22.5 | 32.60 | 24.5 |
| DB330-40 | 330 | 40 | 99.80 | 22.5 | 32.60 | 26.5 |
| DB330-41 | 330 | 41 | 102.38 | 22.5 | 32.60 | 27.5 |
| DB330-45 | 330 | 45 | 112.68 | 22.5 | 32.60 | 31.5 |
| DB330-50 | 330 | 50 | 125.55 | 22.5 | 32.60 | 36.5 |
| DB330-60 | 330 | 60 | 151.30 | 22.5 | 32.60 | 46.5 |
| DB359-30 | 359 | 30 | 74.94 | 22.5 | 55.50 | 7 |
| DB359-32 | 359 | 32 | 80.56 | 22.5 | 55.50 | 9 |
| DB359-35 | 359 | 35 | 88.99 | 22.5 | 55.50 | 12 |
| DB359-40 | 359 | 40 | 103.04 | 22.5 | 55.50 | 17 |
| DB359-45 | 359 | 45 | 117.10 | 22.5 | 55.50 | 22 |
| DB359-50 | 359 | 50 | 131.20 | 22.5 | 55.50 | 27 |
| DB406-20 | 406 | 20 | 58.71 | 22.5 | 39.80 | 3.5 |
| DB406-22 | 406 | 22 | 65.05 | 22.5 | 39.80 | 5.5 |
| DB406-25 | 406 | 25 | 74.56 | 22.5 | 39.80 | 8.5 |
| DB406-28 | 406 | 28.5 | 85.66 | 22.5 | 39.80 | 12 |
| DB406-30 | 406 | 30 | 90.40 | 22.5 | 39.80 | 13.5 |
| DB406-32 | 406 | 32 | 96.75 | 22.5 | 39.80 | 15.5 |
| DB406-35 | 406 | 35 | 106.26 | 22.5 | 39.80 | 18.5 |
| DB406-38 | 406 | 38 | 115.77 | 22.5 | 39.80 | 21.5 |
| DB406-40 | 406 | 40 | 122.12 | 22.5 | 39.80 | 23.5 |
| DB406-41 | 406 | 41 | 125.29 | 22.5 | 39.80 | 24.5 |
| DB406-44 | 406 | 44.45 | 136.38 | 22.5 | 39.80 | 27.95 |
| DB406-45 | 406 | 45 | 137.97 | 22.5 | 39.80 | 28.5 |
| DB406-50 | 406 | 50 | 153.82 | 22.5 | 39.80 | 33.5 |
| DB406-60 | 406 | 60 | 185.52 | 22.5 | 39.80 | 43.5 |
| DB480-35 | 480 | 35 | 125.76 | 22.5 | 42.70 | 17.3 |
| DB480-40 | 480 | 40 | 144.62 | 22.5 | 42.70 | 22.3 |
| DB480-45 | 480 | 45 | 163.48 | 22.5 | 42.70 | 27.3 |

Notes:

Please talk to us about the possibility of supplying alternative gauges and bevel angles to those shown. We can produce a range of thicknesses for the same bevel width.

1.4 CUTTING EDGE

Boron steel

We offer 3 boron-treated steels with a nominal carbon content of 0.3%. Increasing levels of alloy content are available to allow customers to match section thickness and heat-treatment quench severity with hardenability. This ensures a suitable core hardness is achieved in the finished blade.

| | Steel specification | Carbon (%) | Chrome (%) |
|-----------------|---------------------|------------|------------|
| Standard carbon | C30Cr0 | 0.30 | - |
| | C30Cr15 | 0.30 | 0.15 |
| | C30Cr50 | 0.30 | 0.50 |

Hardenability curves - Boron steel (standard carbon content)

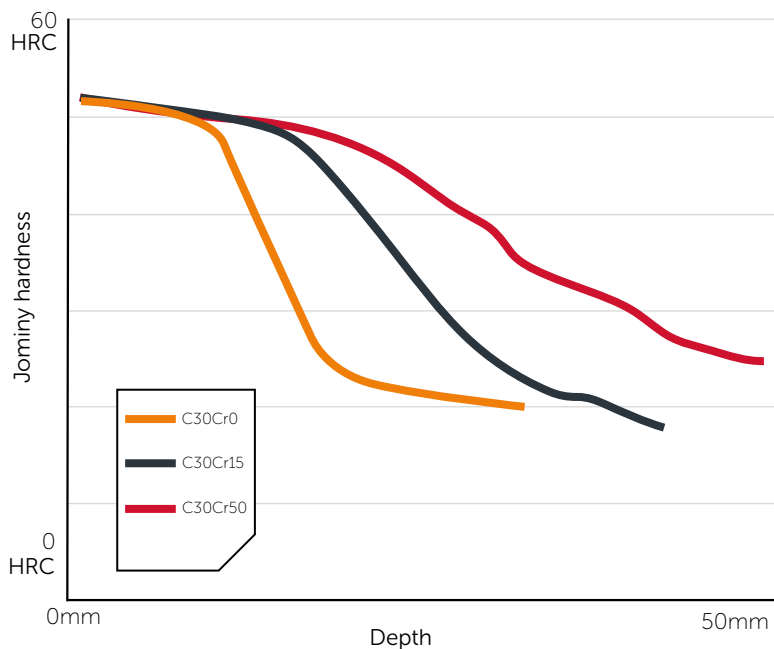

Steel for arrowhead flats

We recommend use of the following steel grades. They are suitable for 'weld in' bucket edges as well as bolt-on applications (appropriate weld procedure required).

| Section | Steel specification | Carbon (%) | Chrome (%) |
|---------|---------------------|------------|------------|
| AH203 | C25Cr40 | 0.25 | 0.40 |
| AH255 | C20Cr50 | 0.20 | 0.50 |

1.4 CUTTING EDGE

Boron steels with reduced carbon

A range of boron-treated steels is available with a lower nominal carbon content of between 0.20% and 0.25%. Heat-treatment of the blade improves toughness levels without significant loss of hardness. The optimum application of our standard and lower carbon range of boron steels depends both on the section thickness and on heat-treatment, particularly with respect to the quench severity.

| | Steel specification | Carbon (%) | Chrome (%) |
|------------|---------------------|------------|------------|
| Low carbon | C20Cr50 | 0.20 | 0.50 |
| | C25Cr10 | 0.25 | 0.10 |
| | C25Cr40 | 0.25 | 0.40 |
| | C25Cr45 | 0.25 | 0.45 |
| | C25Cr75 | 0.25 | 0.75 |
| | C25Cr90 | 0.25 | 0.90 |

Hardenability curves - Boron steel (reduced carbon content)

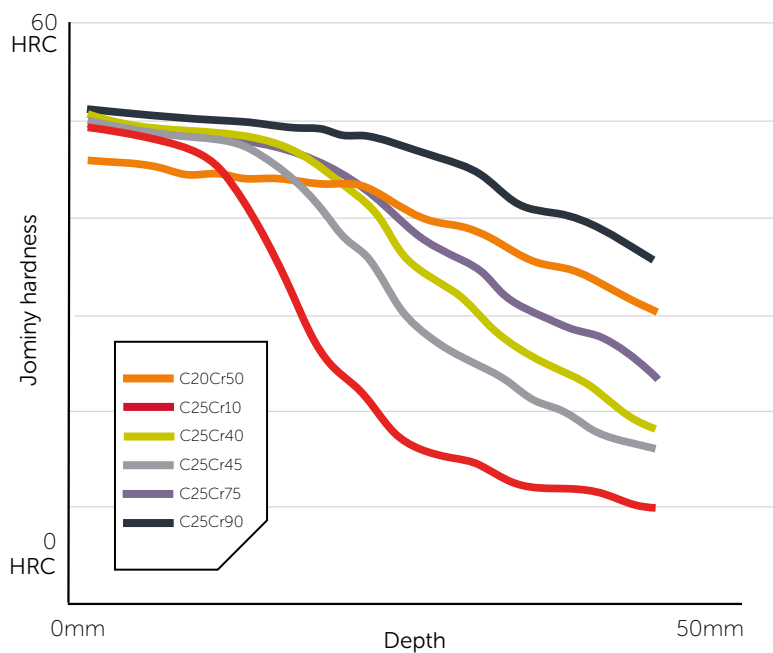

1.5 FORKLIFT PROFILES



1.5 FORKLIFT PROFILES

Mast sections and fork arm flats for material handling equipment

We are a world-leading supplier with over 40 years' experience in producing forklift truck components.

Our extensive range of products is used in everything from the smallest warehouse truck to the largest container handler and includes:

- Mast profiles – including U, I, J and offset J profiles
- Carriage (hanger) bar profiles
- Flats for manufacturing fork arms
- Our range includes 'open' roll profiles available to all customers and for mast and carriage bar profiles; unique 'bespoke' profile designs where rolls and tooling are reserved for exclusive customer use

We're focused on achieving exceptional surface quality; a £2m investment programme has enabled British Steel to continue delivering products that satisfy the ever-increasing demands of today's marketplace.



1.5 FORKLIFT PROFILES

Forklift mast profiles

We recognise the mast assembly as crucial to overall truck performance and work closely with our customers to develop the optimum mast shape and steel properties for every truck application.

World beating product capability

Our range of low-carbon, high-strength, low-alloy steels is ideal for mast manufacture.

Ongoing investment and continuous improvement in our processes are ensuring excellent shape, dimensional tolerances and surface quality.

The open roll profile sizes below are illustrative of the wide range that we can produce (subject to tooling availability).

Channels

| Size (mm) | Kg/m |
|------------|------|
| 121 x 41 | 20.9 |
| 135 x 53 | 28.6 |
| 145 x 48** | 27.1 |
| 157 x 61 | 35.9 |
| 166 x 65 | 19.8 |
| 175 x 66 | 42.9 |
| 201 x 71 | 52.3 |
| 252 x 90 | 78.5 |
| 267 x 95* | 92.3 |



Beams

| Size (mm) | Kg/m |
|------------|------|
| 98 x 62 | 19.4 |
| 101 x 60** | 17.8 |
| 114 x 66 | 25.3 |
| 130 x 81 | 34.1 |
| 140 x 70** | 30.9 |
| 140 x 76* | 33.1 |
| 149 x 67 | 26.7 |
| 152 x 83 | 40.5 |
| 175 x 76** | 42.0 |
| 175 x 90 | 51.4 |
| 216 x 89 | 59.1 |
| 229 x 127* | 87.2 |



Special channels

| Size (mm) | Kg/m |
|---------------|------|
| 145 x 54 x 48 | 26.7 |
| 163 x 61 x 48 | 29.0 |
| 185 x 67 x 54 | 39.2 |
| 226 x 73 x 54 | 50.6 |

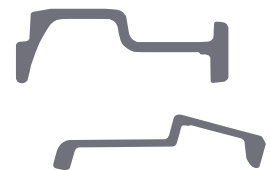

J & Offset J

| Size (mm) | Kg/m |
|----------------|------|
| 103 x 63 x 38 | 17.3 |
| 121 x 68 x 41 | 25.2 |
| 135 x 90 x 53 | 34.9 |
| 157 x 105 x 61 | 43.9 |



*Readily available from our Skinningrove site
**USA standard

1.5 FORKLIFT PROFILES

Fork arm flats

Our profiles for the manufacture of fork arms are available in a wide range of sizes to support the optimum lift capacity for your requirements.

Boron steel grades

Our fork arm flats are boron-treated for increased strength. The Jominy hardenability ensures that after quenching and tempering, consistent mechanical properties can be achieved across the full range of thicknesses. Other steel specifications may be available on request.

Fork arm flats dimensional capability

| Thickness (mm) | Width (mm) | | | | | | |
|----------------|------------|-----|-----|-----|-----|-----|-----|
| | 100 | 120 | 122 | 150 | 180 | 200 | 250 |
| 35 | ● | ● | ● | | | | |
| 40 | ● | ● | ● | ● | | | |
| 45 | ● | ● | ● | ● | ● | ● | |
| 50 | ● | ● | ● | ● | ● | ● | |
| 55 | ● | ● | ● | ● | ● | ● | |
| 60 | ● | ● | ● | ● | ● | ● | |
| 65 | | | | ● | ● | ● | |
| 70 | | | | ● | ● | ● | |
| 75 | | | | ● | ● | ● | ● |
| 80 | | | | | ● | ● | ● |
| 85 | | | | | ● | ● | ● |
| 90 | | | | | ● | ● | ● |
| 95 | | | | | | ● | ● |
| 100 | | | | | | ● | ● |
| 105 | | | | | | | ● |
| 110 | | | | | | | ● |
| 115 | | | | | | | ● |
| 120 | | | | | | | ● |
| 125 | | | | | | | ● |
| 130 | | | | | | | ● |
| 135 | | | | | | | ● |
| 140 | | | | | | | ● |
| 145 | | | | | | | ● |
| 150 | | | | | | | ● |

1.6 TOPHAT



1.6 TOPHAT

Shaft guides for mining applications

Our tophat shaft guides offer a high-quality, cost-effective hoisting system for use in vertical mineshafts. They're designed to give maximum productivity and service life in modern deep mine operations.

We have been working with the manufacturers of mining equipment for many years and understand equipment must be carefully designed and built to meet exacting demands.

Our unique open section tophat guides offer many benefits including:

- Faster installation and replacement
- Pre-installation of butt strap connections
- Cost-effective installation
- Easier inspection and detection of defects
- 3 x longer life than alternative solutions
- Close-dimensional control and straightness, meaning less swing in the shaft and a smoother lift
- Faster hoisting speeds due to their stiffness and higher resistance to slamming forces



1.6 TOPHAT

Standard dimensions

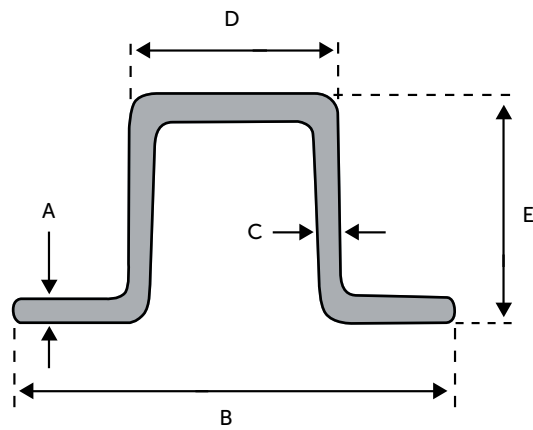

| Size | Weight | Modulus I _{xx} (cm ⁴) | A (mm) | B (mm) | C (mm) | D (mm) | E (mm) |
|-------------|-----------|--|--------|--------|--------|--------|--------|
| 232 x 98mm* | 45.27kg/m | 671 | 16 | 232 | 13.4 | 152 | 98 |
| 305 x 102mm | 55.07kg/m | 997 | 12.7 | 305 | 15.9 | 152 | 102 |
| 320 x 150mm | 71.39kg/m | 2815 | 13.5 | 320 | 18 | 150 | 150 |
| 340 x 175mm | 85.94kg/m | 4392 | 15 | 340 | 20 | 175 | 175 |

*Available under licence from Robor, contact us for more information

All 4 sizes are offered with dimensions as follows:

- Straightness 5mm max over 12m length
- Twist 3mm max (typical < 1mm)
- Shaft guides are available in lengths from 6-17m, with a cutting tolerance of +100/-0mm
- Cold sawn lengths are also available to suit individual requirements, with a +0/-2mm cutting tolerance

Standard steel grades:

- EN 10025-2: 2004, S355JR+AR, S355J2+AR
- SANS 50025-2: 2009, S355JR+AR, S355J2+AR
- CSA G40.21-04: 2004, 300W, 350W, 350WT
- AS/NZS 3679.1: Grade 350

1.6 TOPHAT

Relative performance

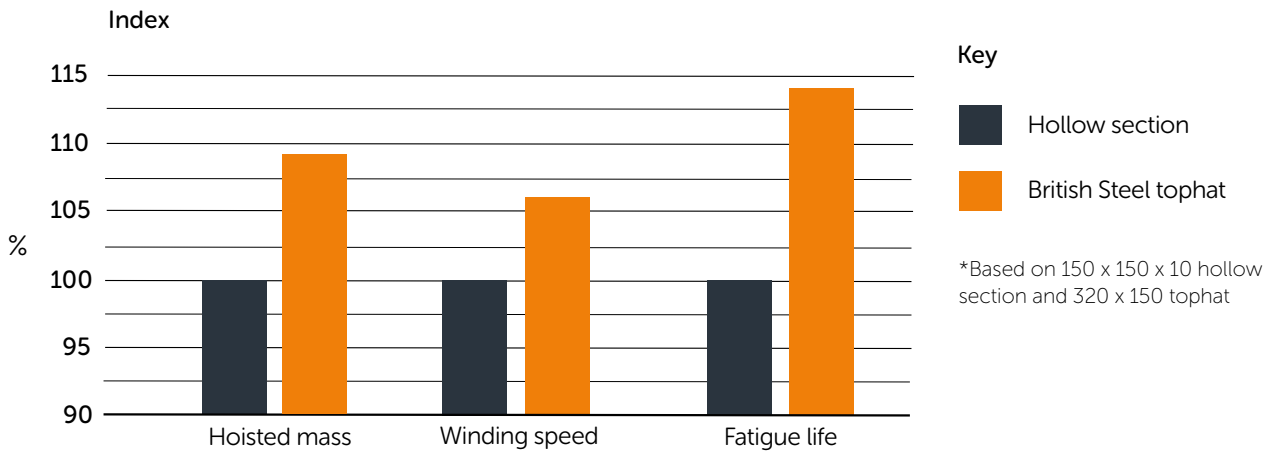

- The chart shows the superior performance of tophat shaft guides relative to other guide rail sections on 3 different factors
- The analysis is based on the dynamic forces applied to the shaft steelwork in the plane of the guides only
- Graph assumes all guide sections are used with the same bunton spacing (i.e. shaft pocket spacing is already fixed)

1.6 TOPHAT

Technical data

232x98mm (45.27kg/m) – SANS 50025:2 S355JR+AR

| | | Centroid | Centre of mass |
|--------------|---------|----------------|----------------|
| Perimeter | 771.917 | X:116.165 | X:116.165 |
| Surface area | 5773.66 | Y:54.6141 | Y:54.6141 |
| Mass | 45.2805 | Z:-1.0599e-019 | Z:-1.0599e-019 |

| | | Moments of inertia | Products of inertia |
|----------------|--|--------------------|---------------------|
| Centre of mass | | X:55768.9 | XY:-30.0664 |
| | | Y:212574 | XZ:1.40654e-020 |
| | | Z:4268343 | YZ:-5.64846e-018 |

| Principal moments | Principal directions | | |
|-------------------|----------------------|----------|-----------|
| X:55768.9 | 1.000000 | 0.000912 | 0.000000 |
| Y:212574 | 0.000912 | 1.000000 | -0.000000 |
| Z:268343 | -0.000000 | 0.000000 | 1.000000 |

| Radii of gyration | X | 35.0946 |
|-------------------|---|---------|
| | Y | 68.5172 |
| | Z | 76.892 |

305x102mm (55.1kg/m) – SANS 50025:2 S355JR+AR

| | | Centroid | Centre of mass |
|--------------|---------|-----------------|-----------------|
| Perimeter | 941.042 | X:152.36 | X:152.36 |
| Surface Area | 7016.53 | Y:50.7022 | Y:50.7022 |
| Mass | 55.0278 | Z:-1.62353e-014 | Z:-1.62353e-014 |

| | | Moments of inertia | Products of inertia |
|----------------|--|--------------------|---------------------|
| Centre of mass | | X:78195.5 | XY:82.3751 |
| | | Y:343178 | XZ:9.9699e-014 |
| | | Z:421374 | YZ:1.43119e-012 |

| Principal moments | Principal directions | | |
|-------------------|----------------------|-----------|----------|
| X:78195.5 | 1.000000 | 0.000311 | 0.000000 |
| Y:343178 | -0.000311 | 1.000000 | 0.000000 |
| Z:421374 | -0.000000 | -0.000000 | 1.000000 |

| Radii of gyration | X | 37.6964 |
|-------------------|---|---------|
| | Y | 78.9712 |
| | Z | 87.507 |

1.6 TOPHAT

Technical data

320x150mm (71.39kg/m) – SANS 50025:2 S355JR+AR

| | | Centroid | Centre of mass |
|--------------|---------|-----------------|-----------------|
| Perimeter | 1140.91 | X:159.968 | X:159.968 |
| Surface Area | 9046.97 | Y:74.9227 | Y:74.9227 |
| Mass | 70.9517 | Z:-4.78417e-014 | Z:-4.78417e-014 |

| | | Moments of inertia | Products of inertia |
|----------------|--|--------------------|---------------------|
| Centre of mass | | X:220763 | XY:136.929 |
| | | Y:448707 | XZ:-4.44512e-013 |
| | | Z:669470 | YZ:4.48865e-011 |

| Principal moments | Principal directions | | |
|-------------------|----------------------|-----------|-----------|
| X:220763 | 1.000000 | 0.000601 | -0.000000 |
| Y:448707 | -0.000601 | 1.000000 | 0.000000 |
| Z:669470 | 0.000000 | -0.000000 | 1.000000 |

| Radii of gyration | X | 55.7804 |
|-------------------|---|---------|
| | Y | 79.5243 |
| | Z | 97.1369 |

340x175mm (85.94kg/m) – SANS 50025:2 S355JR+AR

| | | Centroid | Centre of mass |
|--------------|---------|------------|----------------|
| Perimeter | 1273.97 | X:170.000 | X:170.000 |
| Surface Area | 1107.68 | Y:-89.1562 | Y:-89.1562 |
| Mass | 85.94 | - | - |

| | | Moments of inertia | Products of inertia |
|----------------|--|--------------------|---------------------|
| Centre of mass | | X:46099753.6 | XY:0.0000 |
| | | Y:83962559.1 | - |
| | | - | - |

| Principal moments | Principal directions | | |
|-------------------|----------------------|----------|---|
| X:46099753.6 | 1.000000 | 0.000000 | - |
| Y:83962559.1 | 0.000000 | 1.000000 | - |
| - | - | - | - |

| Radii of gyration | X | 64.4225 |
|-------------------|---|---------|
| | Y | 86.9423 |
| | - | - |

1.7 TRACKSHOE PROFILES



1.7 TRACKSHOE PROFILES

For enhanced crack-resistance and prolonged shoe life

We supply an extensive range of special profiles for the manufacture of earthmoving equipment components. Our range of 'long bar' profiles for track shoes is the most comprehensive in the world.

We work closely with our customers in the earth moving equipment industry, optimising both steel and design for these demanding applications. Our proven track shoe sections deliver benefits for heavy equipment performance and customer processes.

Major benefits of our track shoe sections and related services include:

- Prolonged shoe life – our low carbon and sulphur steels deliver improved crack resistance – even in harsh operating conditions
- Reliable quality – our ongoing investment in plant – including superior straightening capability – delivers products of reliable quality for fast and efficient processing
- Improved process efficiency – our green track shoe offers excellent pre-heat treatment mechanical properties – so you can be confident of optimising your process efficiency
- Fast response – short lead times and small batch sizes (from as little as 130 tonnes) mean we can respond swiftly to your needs
- Global support – we have vast experience in exporting track shoes. Our well-established logistics chains coupled with our international sales support network, mean you can rely on us to deliver – wherever you are



1.7 TRACKSHOE PROFILES

Product range

The track shoe profiles we produce are supplied in customer lengths from 6m to 12m – lengths outside of this range may be available on request. We also offer a variety of different bundling configurations to suit your needs. Profile widths range from 173mm to 369mm. Alternative gauges may be available – please contact us to discuss your requirements.

Single grousers

- Superior ground penetration for bulldozers
- General soil/rocky ground - depending on thickness of profile
- Longer spike = improved traction

| Section | W (mm) | H (mm) | T (mm) | Kg/m | Link pitch (mm) |
|----------|--------|--------|--------|--------|-----------------|
| SG179 | 179 | 62.7 | 9.10 | 19.37 | 165.9 |
| SG180 | 180 | 47.0 | 9.00 | 18.06 | 156.0 |
| SG181 | 181 | 49.0 | 9.50 | 19.31 | 159.8 |
| SG193 | 193 | 52.3 | 11.20 | 22.01 | 159.0 |
| SG197-23 | 197 | 57.2 | 11.50 | 23.72 | 170.0 |
| SG197-25 | 197 | 57.2 | 12.70 | 25.60 | 170.0 |
| SG199 | 199 | 55.0 | 12.00 | 25.19 | 170.5 |
| SG200 | 200 | 47.0 | 11.00 | 21.49 | 171.5 |
| SG232 | 232 | 65.0 | 12.00 | 31.04 | 203.2 |
| SG237 | 237 | 58.7 | 13.80 | 32.50 | 196.2 |
| SG245 | 245 | 71.5 | 14.70 | 38.76 | 203.2 |
| SG248-44 | 248 | 71.4 | 15.00 | 44.67 | 210.3 |
| SG248-48 | 248 | 71.4 | 16.67 | 48.47 | 210.3 |
| SG249-37 | 249 | 66.5 | 13.50 | 37.29 | 215.9 |
| SG249-41 | 249 | 66.5 | 16.00 | 41.84 | 215.9 |
| SG250 | 250 | 65.0 | 14.30 | 40.88 | 216.0 |
| SG263-57 | 263 | 77.8 | 19.10 | 57.29 | 228.6 |
| SG263-70 | 263 | 93.0 | 23.00 | 70.58 | 228.6 |
| SG268-50 | 268 | 80.0 | 17.00 | 50.26 | 228.6 |
| SG268-59 | 268 | 80.0 | 19.00 | 59.25 | 228.6 |
| SG276 | 276 | 76.5 | 17.50 | 48.30 | 228.6 |
| SG285-62 | 285 | 84.0 | 19.00 | 62.60 | 240.0 |
| SG285-64 | 285 | 84.0 | 20.00 | 64.59 | 240.0 |
| SG289 | 289 | 79.0 | 19.00 | 64.31 | 250.5 |
| SG292 | 292 | 76.0 | 17.00 | 54.80 | 250.5 |
| SG299 | 299 | 100.0 | 23.00 | 83.71 | 260.4 |
| SG303 | 303 | 89.7 | 20.60 | 74.93 | 260.4 |
| SG304 | 304 | 88.0 | 22.00 | 77.51 | 260.4 |
| SG322 | 322 | 93.0 | 23.00 | 83.81 | 280.0 |
| SG369 | 369 | 102.0 | 25.00 | 103.00 | 317.5 |

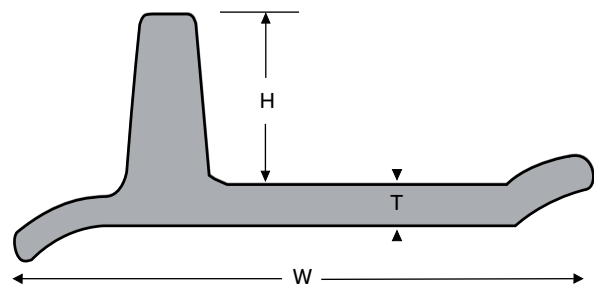

1.7 TRACKSHOE PROFILES

Double grousers

- Good traction for loaders with less damage to ground surface
- Shorter spikes = greater manoeuvrability

| Section | W (mm) | H (mm) | T (mm) | Kg/m | Link pitch (mm) |
|----------|--------|--------|--------|-------|-----------------|
| DG202-26 | 202 | 31.0 | 11.5 | 26.17 | 172.5 |
| DG202-28 | 202 | 31.0 | 13.0 | 28.39 | 172.5 |
| DG217 | 217 | 35.0 | 13.0 | 33.04 | 190.5 |
| DG250 | 250 | 37.0 | 16.5 | 48.12 | 216.0 |
| DG252 | 252 | 49.0 | 15.5 | 50.17 | 216.0 |
| DG308-71 | 308 | 49.5 | 21.0 | 71.90 | 258.5 |
| DG308-80 | 308 | 49.5 | 25.0 | 80.17 | 258.5 |

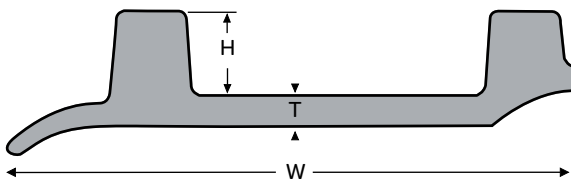

Triple grousers

- Stable operating platform/improved manoeuvrability for excavators
- Hard and soft ground applications

| Section | W (mm) | H (mm) | T (mm) | Kg/m | Link pitch (mm) |
|----------|--------|--------|--------|-------|-----------------|
| TG173 | 173 | 19.0 | 7.9 | 19.02 | 150.7 |
| TG187 | 187 | 21.4 | 9.5 | 22.77 | 159.0 |
| TG199-24 | 199 | 25.0 | 9.5 | 24.44 | 170.0 |
| TG199-25 | 199 | 25.0 | 9.5 | 24.88 | 170.7 |
| TG203-30 | 203 | 25.3 | 12.7 | 30.00 | 168.0 |
| TG203-35 | 203 | 25.3 | 16.0 | 35.41 | 168.0 |
| TG218 | 218 | 26.0 | 10.0 | 28.91 | 187.9 |
| TG220-25 | 220 | 25.5 | 8.5 | 25.67 | 189.0 |
| TG220-27 | 220 | 25.5 | 9.5 | 27.37 | 189.0 |
| TG228-37 | 228 | 32.0 | 12.0 | 37.81 | 206.1 |
| TG228-41 | 228 | 32.0 | 14.0 | 41.36 | 206.1 |
| TG245-50 | 245 | 26.5 | 20.0 | 50.75 | 215.9 |
| TG245-56 | 245 | 26.5 | 22.5 | 56.37 | 215.9 |
| TG247 | 247 | 36.0 | 11.0 | 40.09 | 216.0 |
| TG248 | 248 | 36.0 | 11.0 | 40.10 | 216.0 |
| TG266 | 266 | 30.0 | 30.0 | 70.18 | 228.6 |

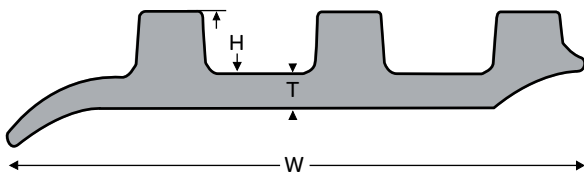

1.7 TRACKSHOE PROFILES

Standard steels

We offer a range of boron-treated steels with a nominal carbon content of 0.3%. Increased levels of alloy content are available to allow customers to match hardenability, section size and heat treatment quench severity. This ensures the most suitable core hardness in the finished track shoe.

| | Steel specification | Carbon (%) | Chrome (%) |
|-----------------|---------------------|------------|------------|
| Standard carbon | C30Cr0 | 0.30 | - |
| | C30Cr15 | 0.30 | 0.15 |
| | C30Cr50 | 0.30 | 0.50 |

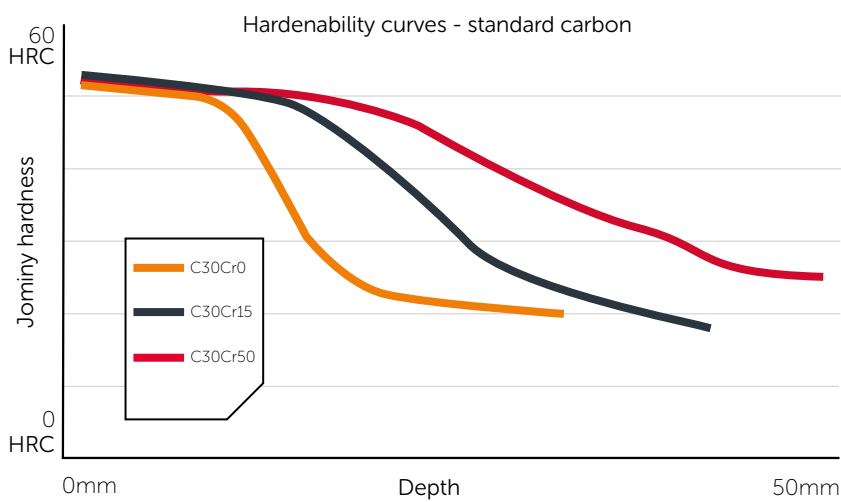

1.7 TRACKSHOE PROFILES

Lower carbon steels

A range of boron-treated steels is available with low sulphur and/or a lower carbon content of 0.25%. This improves crack resistance – prolonging shoe life and enhancing field performance.

| | Steel specification | Carbon (%) | Chrome (%) |
|------------|---------------------|------------|------------|
| Low carbon | C25Cr10 | 0.25 | 0.10 |
| | C25Cr40 | 0.25 | 0.40 |
| | C25Cr45-LS | 0.25 | 0.45 |
| | C25Cr75-LS | 0.25 | 0.75 |

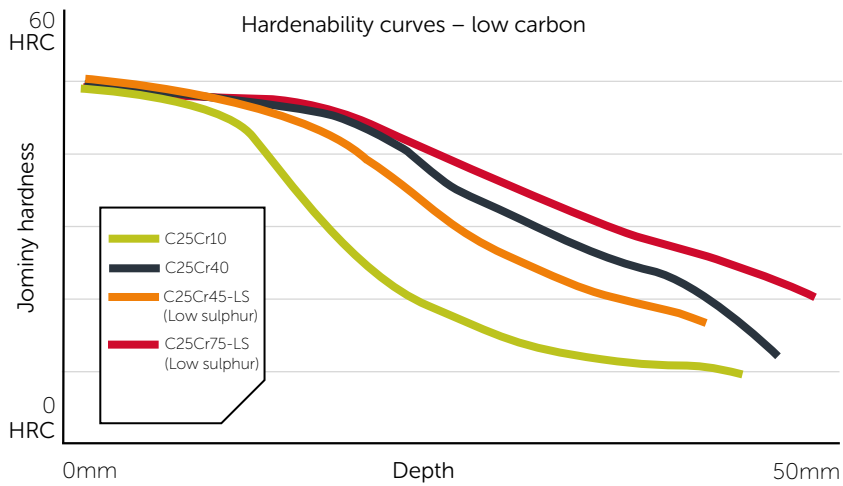

1.8 MELTING BASE IRON (MBI)



1.8 MELTING BASE IRON (MBI)

For vacuum melted super alloys requirements

Our world-class steelmaking expertise provides the capability to produce MBI (Melting Base Iron) products to meet the exacting chemistry required by demanding sectors such as Aerospace, Automotive and Oil & Gas.

With a long history of supply into the industry, we understand the importance of delivering consistent chemistry.

We produce MBI in 250 casts which are then rolled into 75mm square billets in lengths from 6 to 12m. Excellent dimensional control and straightness gives improved stackability and our global reach means our products reach our customers just when you need them.

Product range

| | Product | Steel code | | C | Si | Mn | P | S | Al |
|--------|----------------|------------|-----|-------|-------|------|-------|-------|-------|
| A iron | Low manganese | 9531 | Min | | | | | | |
| | | 5906 | Max | 0.004 | 0.006 | 0.05 | 0.004 | 0.004 | 0.005 |
| B iron | High manganese | 9533 | Min | | | 0.12 | | | |
| | | 5907 | Max | 0.008 | 0.004 | 0.18 | 0.008 | 0.008 | 0.008 |

2 WIRE ROD



ABOUT WIRE ROD

We produce a wide range of wire rod products for markets including automotive, construction, engineering and consumer goods. Our high-performance wire rod and drawn wire meet the strict demands of a huge range of applications, including fasteners, automotive springs, tyre reinforcement, rail clips and bearings.

Our mills, based in Scunthorpe (UK) and Alblasterdam (the Netherlands), have both received IATF 16949 certification – the internationally-adopted quality management system standard for the automotive industry.

We offer a flexible, responsive service, with dedicated technical teams, customer support and local sales network. Our technical team is always on hand to provide advice on steel selection and processing, and our dedicated R&D experts work in partnership with customers, universities and research institutions to develop new and more advanced grades of steel for increasingly demanding applications.

Thanks to our short-cycle rolling programmes and flexible stock solutions, we can deliver precisely the steel you need – just when you need it.

In addition to our mills manufacturing wire rod, our Alblasterdam site also has a state-of-the-art wire processing centre that produces annealed and pickled wire rod and drawn wire for the global automotive, construction and general engineering industries.



Rod Mill, Scunthorpe, UK



Rod Mill and Wire Processing Centre, Alblasterdam, The Netherlands

2.1 COLD HEADING



2.1 COLD HEADING

High-performance wire and wire rod for fasteners and fixings

British Steel cold heading grades offer:

- Excellent hardenability and perform consistently in cold forming and subsequent heat treatments, allowing steel to be used to produce larger /higher strength components (boron steels)
- Improved levels of ductility, formability and strength for use in multiple applications (low carbon aluminium killed steels)

We also offer:

- A dedicated short cycle rolling programme for a comprehensive range of grades and sizes
- Technical expertise to support effective product selection
- Processing via our Wire Processing Centre, Albasserdam

Wire rod dimensions

| | |
|------------------------|---|
| Rod diameter | 5.5 - 30.0mm in 0.5mm increments |
| Coil weight | 1,800 - 2,200kg |
| Coil length | 1,000 - 1,700mm |
| Coil dimensions | Outside diameter: 1,300mm max Inside diameter: 800mm min |

Note:

Coil weight and length are dependent on rod diameter and grade combination. Specific coil package dimensions to be agreed at time of order placement/enquiry.

The following tables indicate the typical chemical analysis for British Steel's cold heading grades. Other grades e.g. silicon-killed can be considered and are available upon request.

Boron grades

| Standard | Grade | Typical supplied chemical analysis (ladle) & tensile strength | | | | | | | | | | |
|------------|-----------|---|-------|-----------|--------|--------|-------------|-----------|--------|-------------|-------------|-----------|
| | | C | Si | Mn | P | S | Al | Cr | N | Ti | B | UTS (MPa) |
| EN 10263-3 | 18B2 | 0.17-0.18 | <0.10 | 0.75-0.80 | <0.015 | <0.015 | 0.025-0.040 | <0.05 | <0.009 | 0.020-0.040 | 0.002-0.004 | 440-500 |
| | 22MnB4 | 0.21-0.22 | <0.10 | 0.93-0.98 | <0.015 | <0.015 | 0.025-0.040 | <0.05 | <0.009 | 0.020-0.040 | 0.002-0.004 | 490-540 |
| | 22MnB4+Cr | 0.22-0.23 | <0.10 | 0.92-0.97 | <0.015 | <0.015 | 0.025-0.040 | 0.25-0.30 | <0.009 | 0.020-0.040 | 0.002-0.004 | 520-580 |
| EN 10263-4 | 17B2 | 0.17-0.18 | <0.10 | 0.80-0.85 | <0.015 | <0.015 | 0.025-0.040 | <0.05 | <0.009 | 0.020-0.040 | 0.002-0.004 | 440-500 |
| | 23B2 | 0.21-0.22 | <0.10 | 0.83-0.88 | <0.015 | <0.015 | 0.025-0.040 | 0.08-0.13 | <0.009 | 0.020-0.040 | 0.002-0.004 | 500-550 |
| | 28B2 | 0.25-0.26 | <0.10 | 0.85-0.90 | <0.015 | <0.015 | 0.025-0.040 | 0.13-0.18 | <0.009 | 0.020-0.040 | 0.002-0.004 | 540-600 |
| | 33B2 | 0.34-0.35 | <0.10 | 0.60-0.65 | <0.015 | <0.015 | 0.025-0.040 | <0.05 | <0.009 | 0.020-0.040 | 0.002-0.004 | 520-580 |
| | 38B2+Cr | 0.37-0.38 | <0.10 | 0.76-0.80 | <0.015 | <0.015 | 0.025-0.040 | 0.20-0.30 | <0.009 | 0.020-0.040 | 0.002-0.004 | 620-670 |
| | 20MnB4* | 0.21-0.22 | <0.10 | 0.90-1.00 | <0.015 | <0.015 | 0.025-0.040 | <0.05 | <0.009 | 0.020-0.040 | 0.002-0.004 | 490-540 |
| | 23MnB4* | 0.21-0.22 | <0.10 | 0.90-1.00 | <0.015 | <0.015 | 0.025-0.040 | <0.05 | <0.009 | 0.020-0.040 | 0.002-0.004 | 490-540 |
| | 30MnB4+Cr | 0.29-0.31 | <0.10 | 0.85-0.90 | <0.015 | <0.015 | 0.025-0.040 | 0.15-0.20 | <0.009 | 0.020-0.040 | 0.002-0.004 | 560-620 |

*Grades also available with chromium addition up to 0.3% max to meet customer requirements.

Aluminium killed grades

| Standard | Grade | Typical supplied chemical analysis (ladle) & tensile strength | | | | | | | | |
|------------|--------|---|-------|-----------|--------|--------|-------------|-------|--------|-----------|
| | | C | Si | Mn | P | S | Al | Cr | N | UTS (MPa) |
| EN 10263-2 | C4C | 0.04-0.05 | <0.05 | 0.33-0.38 | <0.015 | <0.015 | 0.030-0.050 | <0.05 | <0.006 | 350-390 |
| | C8C | 0.06-0.07 | <0.05 | 0.33-0.38 | <0.015 | <0.015 | 0.030-0.050 | <0.05 | <0.006 | 360-400 |
| | C10C | 0.10-0.11 | <0.05 | 0.37-0.42 | <0.015 | <0.015 | 0.030-0.050 | <0.05 | <0.006 | 380-420 |
| | C15C | 0.15-0.16 | <0.05 | 0.50-0.55 | <0.015 | <0.015 | 0.030-0.050 | <0.05 | <0.006 | 430-470 |
| | C17C | 0.18-0.19 | <0.05 | 0.70-0.80 | <0.015 | <0.015 | 0.030-0.050 | <0.05 | <0.006 | 470-520 |
| | C20C | 0.19-0.21 | <0.05 | 0.75-0.85 | <0.015 | <0.015 | 0.030-0.050 | <0.05 | <0.006 | 485-535 |
| EN 10263-3 | C10E2C | 0.10-0.11 | <0.05 | 0.37-0.42 | <0.015 | <0.015 | 0.030-0.050 | <0.05 | <0.006 | 380-420 |
| | C15E2C | 0.15-0.16 | <0.05 | 0.50-0.55 | <0.015 | <0.015 | 0.030-0.050 | <0.05 | <0.006 | 430-470 |
| | C17E2C | 0.18-0.19 | <0.05 | 0.70-0.80 | <0.015 | <0.015 | 0.030-0.050 | <0.05 | <0.006 | 470-520 |

Alloyed grades

| Standard | Grade | Typical supplied chemical analysis (ladle) & tensile strength | | | | | | | | |
|------------|---------|---|-------|-----------|--------|--------|-------------|-----------|-----------|-------------|
| | | C | Si | Mn | P | S | Al | Cr | Mo | B |
| EN 10263-4 | 37Cr4 | 0.34-0.41 | <0.10 | 0.60-0.90 | <0.025 | <0.025 | 0.020-0.060 | 0.90-1.20 | - | - |
| | 41Cr4 | 0.38-0.45 | <0.10 | 0.60-0.90 | <0.025 | <0.025 | 0.020-0.060 | 0.90-1.20 | - | - |
| | 34CrMo4 | 0.30-0.37 | <0.10 | 0.60-0.90 | <0.025 | <0.025 | 0.020-0.060 | 0.90-1.20 | 0.15-0.30 | - |
| | 30MoB1 | 0.28-0.32 | <0.30 | 0.80-1.00 | <0.025 | <0.025 | 0.020-0.060 | 0.20-0.30 | 0.08-0.12 | 0.002-0.005 |



2.2 FREECUTTING



2.1 FREECUTTING STEEL GRADES

Leaded and non-leaded freecutting wire rod for precision components

For the automotive and office equipment markets, our leaded freecutting steels offer an advantage in reduction of processing costs compared to non-leaded products.

These grades are developed for the efficient, accurate and high-speed machining of large volume engineering components. In addition to access to R&D to support development activities, we offer freecutting grades that:

- Are designed to withstand high speed manufacturing processes
- Enhance machinability enabling a reduction in machining times (leaded freecutting grades)
- Offer high performance where a combination of machinability and strength is required
- Promote long tool life
- Are supplied in a comprehensive range of sizes offered via a flexible rolling programme

Wire rod dimensions

| | |
|------------------------|---|
| Rod diameter | 5.5 - 30.0mm in 0.5mm increments |
| Coil weight | 1,800 - 2,200kg |
| Coil length | 1,000 - 1,700mm |
| Coil dimensions | Outside diameter: 1,300mm max Inside diameter: 800mm min |

Note:

Coil weight and length are dependent on rod diameter and grade combination. Specific coil package dimensions to be agreed at time of order placement/enquiry.



2.1 FREECUTTING STEEL GRADES

The following tables indicate the typical chemical analysis for British Steel's freecutting grades. Other grades can be considered and are available upon request.

Leaded freecutting grades

| Standard | Grade | Typical supplied chemical analysis (ladle) | | | | | | |
|--------------|-------------------------|--|-----------|-----------|-----------|-------------|-----------|-------------|
| | | C | Si | Mn | P | S | Pb | N |
| EN ISO 683-4 | 11SMnPb30 | 0.07-0.09 | <0.01 | 1.00-1.05 | 0.05-0.07 | 0.28-0.32 | 0.26-0.29 | - |
| | 11SMnPb30 (High Pb + N) | 0.07-0.09 | <0.01 | 1.05-1.10 | 0.05-0.07 | 0.28-0.32 | 0.29-0.33 | 0.009-0.012 |
| | 11SMnPb37 | 0.07-0.09 | <0.01 | 1.20-1.30 | 0.06-0.08 | 0.35-0.39 | 0.28-0.33 | 0.007-0.012 |
| | 36SMnPb14 | 0.33-0.36 | 0.15-0.19 | 1.45-1.55 | 0.025 max | 0.10-0.14 | 0.20-0.25 | - |
| EN ISO 683-3 | C15Pb | 0.13-0.15 | 0.20-0.25 | 0.40-0.50 | 0.025 max | 0.020-0.030 | 0.20-0.25 | - |
| EN ISO 683-1 | C45Pb | 0.44-0.48 | 0.20-0.25 | 0.60-0.70 | 0.020 max | 0.020-0.040 | 0.20-0.25 | 0.012 max |
| AISI/SAE | 12L14 | 0.07-0.09 | <0.01 | 1.00-1.05 | 0.05-0.07 | 0.28-0.32 | 0.26-0.29 | - |

Non-leaded freecutting grades

| Standard | Grade | Typical supplied chemical analysis (ladle) | | | | | | |
|--------------|---------|--|-----------|-----------|-----------|-----------|-------------|-----------|
| | | C | Si | Mn | P | S | N | Cr |
| EN ISO 683-4 | 11SMn30 | 0.07-0.09 | <0.01 | 0.98-1.02 | 0.05-0.07 | 0.27-0.31 | - | - |
| | 11SMn37 | 0.07-0.09 | <0.01 | 1.20-1.30 | 0.06-0.08 | 0.35-0.39 | 0.007-0.012 | - |
| | 38SMn28 | 0.36-0.38 | 0.15-0.20 | 1.30-1.40 | 0.025 max | 0.27-0.30 | - | 0.07-0.10 |
| | 44SMn28 | 0.42-0.43 | 0.20-0.25 | 1.55-1.60 | 0.025 max | 0.27-0.30 | - | - |
| | 46S20 | 0.44-0.47 | 0.15-0.20 | 1.00-1.05 | 0.025 max | 0.18-0.22 | - | 0.12-0.17 |
| AISI/SAE | 1144 | 0.42-0.43 | 0.20-0.25 | 1.55-1.60 | 0.025 max | 0.27-0.30 | - | - |
| | 1215 | 0.07-0.09 | <0.01 | 0.98-1.02 | 0.05-0.07 | 0.27-0.31 | - | - |

2.3 TYRE --- REINFORCEMENT



2.3 TYRE REINFORCEMENT STEEL GRADES

Steel products for tyre reinforcement

For the automotive market, our tyre cord wire rod provides a tyre with strength, shape and durability, as well as improving performance and longevity. We produce high-strength steel for the production of tyre cord that can be tailored to individual customer specifications:

- Tensile strength can be altered by adapting the steel microstructure
- Scale characteristics can be tailored to meet the customers' preferred method of descaling

For tyre cord and tyre bead customers, we offer:

- Technical expertise and responsiveness
- A non-integrated supply chain allowing our customers to plan their workload and collaborate with us to develop bespoke tailored solutions

Wire rod dimensions

| | |
|------------------------|---|
| Rod diameter | 5.5 mm |
| Coil weight | 1,800 - 2,200kg |
| Coil length | 1,350 - 1,700mm |
| Coil dimensions | Outside diameter: 1,250mm max Inside diameter: 850mm min |

Note:

Standard tyre reinforcement wire rod dimensional tolerances: Gauge +/-0.20mm, ovality 0.30mm max

Steel grade

The table below indicates the typical chemical analysis limits for our tyre reinforcement grades. Other grades and analysis limits can be considered upon request. Typical tensile strengths and reduction of area are displayed, however these can be tailored through process route optimisation.

| Grade | C | Si | Mn | P | S | N | Cr | Tensile (MPa) | Reduction of area (%) |
|--------|-------------|-------------|-------------|--------|--------|--------|-------------|---------------|-----------------------|
| 62C | 0.62 – 0.65 | 0.19 – 0.22 | 0.48 – 0.53 | ≤0.011 | ≤0.011 | ≤0.006 | – | 920 | ≥46 |
| 72C | 0.71 – 0.75 | 0.19 – 0.22 | 0.48 – 0.52 | ≤0.014 | ≤0.009 | ≤0.006 | – | 1030 | ≥40 |
| 84C | 0.81 – 0.84 | 0.19 – 0.22 | 0.48 – 0.51 | ≤0.013 | ≤0.012 | ≤0.006 | – | 1120 | ≥37 |
| 95C+Cr | 0.90 – 0.95 | 0.19 – 0.22 | 0.33 – 0.37 | ≤0.014 | ≤0.009 | ≤0.006 | 0.20 – 0.24 | 1260 | ≥37 |

2.4 AUTOMOTIVE --- SPRING STEEL



2.4 AUTOMOTIVE SPRING STEEL

Carbon alloy wire rod for oil-tempered automotive springs

The production of suspension springs requires super clean consistent quality steel. These springs are in constant motion when in use in safety-critical applications.

For our Automotive customers, our spring steel products offer 2 main advantages: reliability and short delivery lead time. This is in addition to:

- Rigorous testing to meet customers stringent requirements
- A comprehensive size range to satisfy automotive requirements
- Access to dedicated technical expertise

Wire rod dimensions

| | |
|------------------------|---|
| Rod diameter | 5.5 - 16.0mm in 0.5mm increments |
| Coil weight | 1,800 - 2,200kg |
| Coil length | 1,000 - 1,700mm |
| Coil dimensions | Outside diameter: 1,300mm max Inside diameter: 800mm min |

Note:

Coil weight and length are dependent on rod diameter and grade combination. Specific coil package dimensions to be agreed at time of order placement/enquiry.

The table below indicates the typical chemical analysis levels for our automotive spring steel grades.

| Standard | Grade | C | Si | Mn | P | S | Cr | V |
|----------|----------|-------------|-------------|-------------|---------|---------|-------------|-----------|
| EN 10089 | 54SiCr6 | 0.52 – 0.56 | 1.40 – 1.50 | 0.60 – 0.70 | < 0.015 | < 0.010 | 0.60 – 0.70 | - |
| | 54SiCrV6 | 0.53 – 0.57 | 1.35 – 1.45 | 0.60 – 0.70 | < 0.015 | < 0.010 | 0.52 – 0.62 | 0.10/0.15 |

Note:

Sizes available subject to technical referral



2.5 RAIL CLIP



2.5 RAIL CLIP

High-performance wire rod for rail clip applications

For the rail industry our dedicated technical team and responsive global sales team offer support to meet the exacting requirements of rail clip applications.

Our 38SiCr7 offers:

- Uniform microstructure to facilitate downstream processing
- Dimensional accuracy and surface quality
- Can also be supplied in annealed and/or drawn condition

Wire rod dimensions

| | |
|------------------------|---|
| Rod diameter | 5.5 – 16mm |
| Coil weight | 1,800 – 2,200kg |
| Coil length | Max 1,400mm |
| Coil dimensions | Outside diameter: 1,300mm max Inside diameter: 800mm min |

The table below indicates the typical chemical analysis levels for British Steel's spring steel grades for rail clip applications.

| Standard | Grade | C | Si | Mn | P | S | Cr | V |
|-----------------------------|-------|-----------|-----------|-----------|-----------|-----------|----------|----------|
| Wsn 1.5023 Acc. EN 10089 | 38Si7 | 0.35-0.42 | 1.50-1.80 | 0.50-0.80 | Max 0.025 | Max 0.025 | Max 0.30 | Max 0.10 |

As-rolled properties:

- Material has a uniform ferrite/pearlite structure
- Tensile Strength: Rm = 700-850 MPa
- Reduction of Area: Z = min 50%

2.6 BEARING STEEL



2.6 BEARING STEEL GRADES

Bearing wire rod and wire grades for processing into balls, rollers, needles and axles

Bearings demand clean, fatigue-resistant wire rod and wire with consistent properties to ensure reliable long life. Our bearing grades are:

- Manufactured and tested to ensure steel cleanliness, hardenability, dimensional stability and enhanced formability
- Manufactured using a range of steel making routes to ensure we meet the requirements of demanding applications

Wire rod dimensions

| | |
|------------------------|---|
| Rod diameter | 5.5 - 30.0mm in 0.5mm increments |
| Coil weight | 1,800kg |
| Coil length | 1,000 - 1,300mm |
| Coil dimensions | Outside diameter: 1,300mm max Inside diameter: 800mm min |

Drawn wire dimensions

| | |
|----------------------|--------------|
| Wire diameter | 1.8 - 29.0mm |
|----------------------|--------------|

Note:

Coil size, weight and length are dependent on final size and execution and are available on request. See our Wire Processing Centre datasheet for further information.

2.6 BEARING STEEL GRADES

The table below indicates the chemical composition for the principal grade for bearing applications 100Cr6 (material number 1.3505, SAE 52100, JIS SUJ2, DIN EN ISO 683-17, ASTM A295). Other specific element requirements can be provided, subject to a minimum order quantity.

100Cr6 grade

| Grade | Typical supplied chemical analysis (ladle) & tensile strength (when spheroidise annealed) | | | | | | | | | | | | |
|--------|---|-------------|-------------|--------|--------|--------|-------------|--------|---------|-------|-------|---------|-----------|
| | C | Si | Mn | P | S* | Al | Cr | Mo | Ti | Ni | Cu | O | UTS (MPa) |
| 100Cr6 | 0.93 - 1.05 | 0.15 - 0.35 | 0.25 - 0.45 | <0.025 | <0.008 | <0.050 | 1.35 - 1.60 | <0.010 | <0.0030 | <0.25 | <0.30 | <0.0009 | <680 |

*Resulphurised analyses (S range 0.015 - 0.030%) can also be provided.

Hardening grades

In addition to 100Cr6, we also supply through hardening and case hardening steel grades for bearing applications.

Through hardening grades

| Grade | Material number | C | Si | Mn | Cr | Ni | Mo | O |
|----------|-----------------|-----------|-----------|-----------|-----------|-------|-----------|---------|
| 100CrMn6 | 1.3520 | 0.93-1.05 | 0.40-0.70 | 1.00-1.20 | 1.40-1.65 | <0.30 | <0.10 | <15 ppm |
| 100CrMo7 | 1.3537 | 0.93-1.05 | 0.20-0.40 | 0.25-0.45 | 1.65-1.95 | <0.30 | 0.15-0.25 | <15 ppm |

Case hardening grades

| Grade | Material number | C | Si | Mn | Cr | Ni | Mo | O |
|-----------|-----------------|-----------|-----------|-----------|-----------|-----------|-----------|---------|
| 20NiCrMo7 | | 0.17-0.22 | 0.20-0.40 | 0.45-0.65 | 0.40-0.60 | 1.60-2.00 | 0.20-0.30 | <15 ppm |
| 17MnCr5 | | 0.15-0.20 | 0.15-0.40 | 1.00-1.40 | 0.40-0.80 | 0.20-0.50 | 0.10-0.20 | <15 ppm |
| 20NiCrMo2 | 1.6522 | 0.17-0.23 | 0.15-0.30 | 0.70-0.90 | 0.40-0.60 | 0.40-0.70 | 0.15-0.30 | <15 ppm |

2.7 WELDING STEEL



2.7 WELDING STEEL

Welding wire rod for processing into welding electrodes, MIG / MAG (gas-shielded metal arc) electrodes and submerged arc welding wires

We specialise in wire rod for low and medium alloyed special welding consumables.

- Steel can be further processed by both pickling and mechanical descaling for the optimum surface finish
- More alloyed grades can be delivered in the annealed condition to ensure good drawability

Wire rod dimensions

| | |
|------------------------|---|
| Rod diameter | 5.5 - 10.0mm in 0.5mm increments |
| Coil weight | 1,800 - 2,000kg (steel base dependent) |
| Coil length | 1,000 - 1,400mm |
| Coil dimensions | Outside diameter: 1,300mm max Inside diameter: 850mm min |

Note:

Alternative coil weights and dimensions are available on request.

The table below indicates our representative welding wire grades. Other grades can be considered and are available upon request.

| Type | Standard | Grade | Material number |
|--------------------------------|---------------------|-------------|-----------------|
| MIG / MAG | | | |
| SG 1 | EN ISO 14341 - 2Si | 10MnSi5 | 1.5112 |
| SG 2 | EN ISO 14341 - 3Si1 | 11MnSi6 | 1.5125 |
| SG 3 | EN ISO 14341 - 4Si1 | 10MnSi7 | 1.5130 |
| Electrodes | | | |
| E | EN ISO 2560 | RSD 7 | 1.0324 |
| Sub-merged arc welding | | | |
| S1 | EN ISO 14171 - S1 | RRSD 10 | 1.0351 |
| S2Si | EN ISO 14171 - S2Si | 11Mn4Si | 1.0492 |
| S3 | EN ISO 14171 - S3 | 12Mn6 | 1.0496 |
| S2Mo | EN ISO 14171 - S2Mo | 11MnMo4 5 | 1.5425 |
| Low and medium alloyed* | | | |
| MnSi + Ti | | 13Mn12 | 1.5089 |
| CrMo | AWS ER 80S-B2 | 11CrMo5 | 1.7339 |
| MnCrMo | AWS ER S-D2 | 13MnMo | 1.5428 |
| NiMnMo | AWS ER 80S-Ni2 | 11NiMnMo4-5 | 1.6312 |
| | AWS ER 100S-G | 5NiMnMo8 | |
| CrMoSi | AWS ER 90S-B3 | 9CrMoSi10 | |

*Wire rod for low and medium alloyed welding consumables can be supplied in custom made batches of 30 tonnes min.

2.7 WELDING STEEL

Additional alloys

We can also offer steels with additional alloys up to the maximum content limits in the table below. Please contact us to discuss your requirements.

| | Cr | Ni | Mo | Si | Mn |
|---------|----|----|----|----|----|
| Max w-% | 6 | 4 | 1 | 2 | 2 |

Additions in titanium, zirconium, copper and vanadium may be available upon request.

Maximum possible residual element limits in ladle analysis ^{1),2),3)}

| | P | S | Cr | Mo | Ni | V | Ti | Cu | Pb | Sn | As |
|---------|-------|-------|------|------|------|------|-------|------|------|-------|-------|
| Max w-% | 0.012 | 0.015 | 0.10 | 0.04 | 0.10 | 0.01 | 0.002 | 0.15 | 0.01 | 0.008 | 0.008 |

| | Nb | Ca | Co | Zr | Sb | W | Al | B | Ta | N | O |
|---------|-------|-------|-------|-------|-------|-------|-------|--------|-------|-------|--------|
| Max w-% | 0.005 | 0.001 | 0.010 | 0.005 | 0.005 | 0.005 | 0.010 | 0.0003 | 0.015 | 0.007 | 0.0025 |

¹⁾ Tighter limits possible, to be checked upon request

²⁾ With reservation, depending on alloy content certain residual elements can be different

³⁾ Product analysis limits upon request

2.8 HIGH TENSILE



2.8 HIGH TENSILE

High strength-to-weight ratio wire rod for bridge and deepwater cables

High-tensile bridge and deepwater cables require consistent quality wire rod with high strength to weight ratio. The enhanced strength-to-weight ratio of our high tensile wire rod enables cable cross-sections to be reduced and delivers:

- Reduced cable and superstructure weight (including cable bands, clamps, hanger cables and saddles)
- Reduced cable installation and spinning time
- Reduced construction programme
- Overall project cost savings

We offer:

- Flexible rolling programme
- Support of a dedicated technical team and experienced global sales network
- Technical expertise and R&D facilities to support collaborative development projects

Wire rod dimensions

| | |
|------------------------|---|
| Rod diameter | 5.5 - 15.0mm in 0.5mm increments |
| Coil weight | 1,800 - 2,200kg |
| Coil length | 1,350 - 1,700mm |
| Coil dimensions | Outside diameter: 1,250mm max Inside diameter: 850mm min |

The table below indicates typical as-rolled tensiles, other grades can be considered upon request.

Steel grades

| Grade | Typical carbon % | Significant alloys | Typical tensile strength in 12mm as-rolled rod (N/mm ²) | Typical reduction of area (%) |
|-------|------------------|--------------------|---|-------------------------------|
| M83B | 0.8 | V | 1180 | ≥30 |
| M85B | 0.83 | V | 1220 | ≥30 |
| M90B | 0.88 | V | 1260 | ≥25 |
| X95Cr | 0.93 | Cr | 1220 | ≥25 |
| M94Si | 0.92 | Si, Cr | 1370 | ≥25 |

Note:

Sizes available subject to technical referral



2.9 PC STRAND



2.9 PC STRAND

High carbon wire rod for prestressed wire and prestressed concrete strand

We offer high carbon wire rod for prestressed concrete (PC) strand for the reinforcement of concrete structures in bridge, railway, civil and residential construction. Wire rod for PC strand requires high tensile strength to withstand the highest mechanical stresses.

We offer:

- Short-cycle rolling programme to meet the demands of downstream construction production schedules
- Integrated production process facilitating rigorous inspection at all stages
- Support of a dedicated technical team from point of enquiry and an experienced global sales network

Wire rod dimensions

| | |
|------------------------|---|
| Rod diameter | 8.5 - 13.0mm in 0.5mm increments |
| Coil weight | 1,800 - 2,200kg |
| Coil length | 1,400 - 1,650mm |
| Coil dimensions | Outside diameter: 1,250mm max Inside diameter: 850mm min |
| Presentation | Secured with 4 metal straps/bands and 2 material tallies with grade/supplier info |

Note:

Alternative diameters may be available, subject to technical referral.

The table below indicates the typical chemical composition for our PC strand grade X85CR, other grades may be considered upon request.

| Grade | C | Si | Mn | P | S | Cr | Cu | Mo | Ni | N | Al | V |
|---------|-----------|-----------|-----------|-----------|-----------|-----------|----------|----------|----------|-----------|-----------|----------|
| X85CR | 0.80-0.85 | 0.15-0.30 | 0.65-0.85 | 0.020 max | 0.025 max | 0.20-0.30 | 0.10 max | 0.02 max | 0.10 max | 0.007 max | 0.010 max | 0.01 max |
| Typical | 0.82-0.84 | 0.20-0.25 | 0.78-0.83 | < 0.015 | < 0.020 | 0.25-0.29 | < 0.05 | < 0.010 | < 0.05 | < 0.006 | < 0.005 | < 0.005 |

Mechanical properties

The as-rolled ultimate tensile strength (UTS) and reduction of area (RoA) will be measured and reported (based on batch average testing). Selected UTS ranges are as follows:

| Diameter (mm) | UTS (MPa) | RoA (%) |
|---------------|-------------|---------|
| 11.0 | 1150 - 1250 | 25 min |
| 13.0 | 1130 - 1230 | 25 min |

Note: Decarburisation, cleanliness, core segregation and microstructure are not routinely measured but are expected to be compliant with the minimum requirements of EN 16120-4. Enquiries for enhanced limits should be referred to our technical team.

Certification

Our PC strand grade is supplied in accordance with EN 10204 3.1, with dimensional tolerances in accordance with EN 16124 class T2 (ie +/- 0.25mm, 0.40mm max ovality) and maximum surface imperfection depth in accordance with EN 16120-4 clause 5.4 table 3.

2.10 WIRE PROCESSING CENTRE

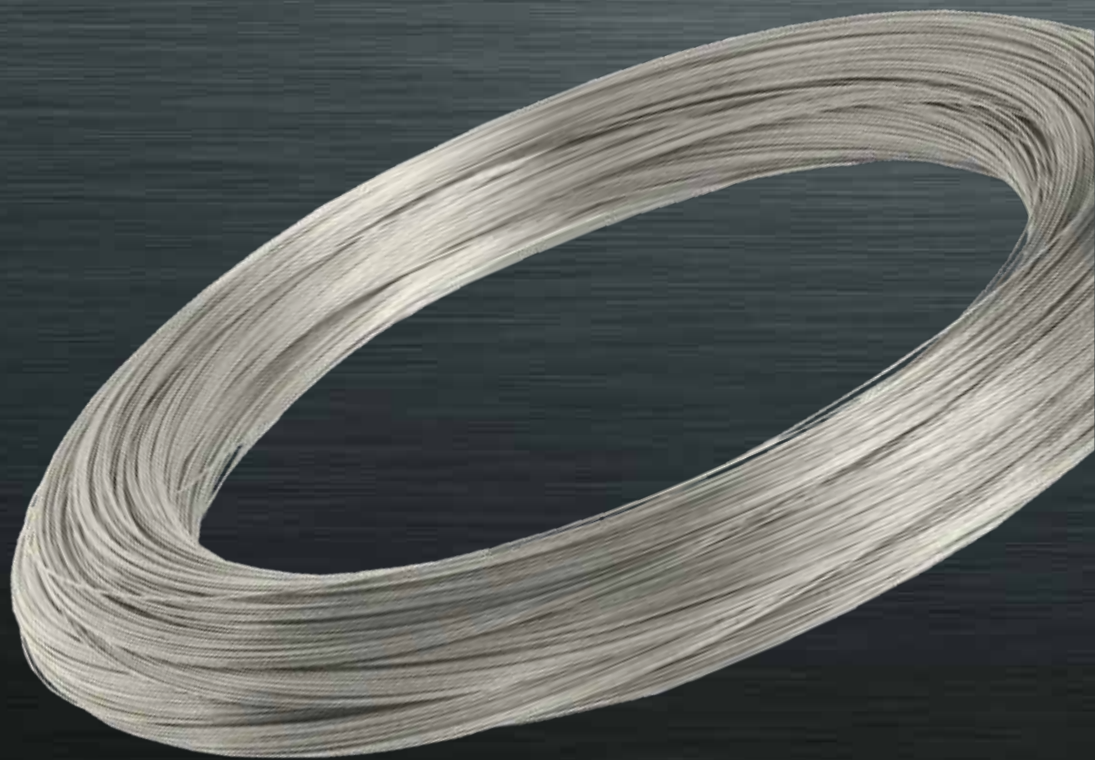

2.10 WIRE PROCESSING CENTRE

Drawing, pickling and annealing to enhance your wire rod and wire products

Our Alblasserdam site produces annealed and pickled wire rod and drawn wire for the global automotive, construction and general engineering industries.

Annealing

To make wire rod more workable, we offer spheroidised annealing, recrystallisation annealing and stress-relief annealing. Our annealing programmes are specifically designed for our different grades.

Pickling

Where surface quality is critical, scale can be removed by hydrochloric acid. We also offer a variety of coatings to further optimise processing e.g. lime, salt carrier, phosphate and soap for drawing and flat-rolling or phosphate and soap or polymer for cold forming and cold extrusion.

Drawing

For downstream processes that require smaller diameters and/or tighter size tolerances, our drawing plant produces drawn wire in a wide variety of grades.

Wire rod dimensions

The table below indicates the typical specifications for our wire rod range, inclusive of material treated via annealing and/or pickling.

Coil properties

| | |
|-----------------|---|
| Rod diameter | 5.5 - 30.0mm in 0.5mm increments |
| Coil weight | 1,800 - 2,200kg |
| Coil length | 1,000 - 1,700mm |
| Coil dimensions | Outside diameter: 1,300mm Inside diameter: 800mm |
| Tolerance | In accordance with EN 10108 A or B |

Notes:

Can be delivered in as rolled, annealed and/or pickled, coated. Coil weight and length are dependent on rod diameter and grade combination. Specific coil package dimensions to be agreed at time of order placement/enquiry.



2.10 WIRE PROCESSING CENTRE

Coil handling

| | |
|---|--|
| Strapping | 4 band straps |
| Labels / tags (as rolled) | 1 plastic with barcode & plain text and 1 metal tag with text |
| Labels / tags (treated wire rod) | 1 plastic with barcode as standard (second label available on request) |

Drawn wire dimensions

| | |
|------------------|--|
| Diameter | 1.8 - 28.0mm |
| Tolerance | In accordance with EN 10278:1999 (h9, h10 or h11 possible) |

Notes:

Available in coils, spooled coils, and on spiders/carriers in a variety of weights and make up - options are dependent on final execution and size). Can be delivered in as drawn, annealed (or combination), coated with phosphate or soap

Treatment conditions

| EN | DIN | Description |
|-------------|-------------|-------------------------------|
| +U+C | K | Drawn |
| +AC+C | GKZ+K | Annealed-drawn |
| +U+C+AC | K+GKZ | Drawn-annealed |
| +U+C+AC+LC | K+GKZ+K | Drawn-annealed-drawn |
| +AC+C+AC+LC | GKZ+K+GKZ+K | Annealed-drawn-annealed-drawn |

3 CONSTRUCTION



ABOUT CONSTRUCTION

We supply a wide range of structural sections to the global construction industry. Our sections have helped create some of the most amazing structures around the world.

Our UK mills in Scunthorpe and Teesside produce a comprehensive range of standard and bespoke sections with unrivalled availability and lead times.

We're responsive and adaptable to customers' needs and take pride in giving great customer service and offering quality products made to precise requirements.

Our standard sections are supplied as-rolled and can be further processed by shotblasting and priming for the perfect finish.

As the only UK manufacturer of heavy structural sections, our steel products are CE and UKCA marked and tested to the highest standards, providing quality and reassurance for the construction market.

Our full section range is tested in accordance with the requirements of BS EN10025-2. Rigorous impact tests are carried out at prescribed temperatures in accordance with this, ensuring full compliance with the Construction Products Regulation.

We're also Environmental and Sustainability Standard BES 6001 certified, guaranteeing commitment to responsibly sourced materials.



3.1 UK SECTIONS



3.1 UK SECTIONS

Universal Beams

Material to EN 10025-2
Nominal dimensions to EN 10365:2017 (where applicable)
Tolerance EN 10034:1993

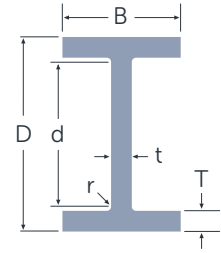

| Designation Serial size | Mass per metre kg/m | Depth of section D mm | Width of section B mm | Thickness | | Root radius r mm | Depth between fillets d mm |
|--------------------------------|----------------------------|---------------------------------|---------------------------------|-----------------------|--------------------------|----------------------------|--------------------------------------|
| | | | | of web t mm | of flange T mm | | |
| | | | | | | | |
| 127 x 76 x 13 | 13.0 | 127.0 | 76.0 | 4.0 | 7.6 | 7.6 | 96.6 |
| 152 x 89 x 16 | 16.0 | 152.4 | 88.7 | 4.5 | 7.7 | 7.6 | 121.8 |
| 178 x 102 x 19 | 19.0 | 177.8 | 101.2 | 4.8 | 7.9 | 7.6 | 146.8 |
| 203 x 102 x 23 | 23.1 | 203.2 | 101.8 | 5.4 | 9.3 | 7.6 | 169.4 |
| 203 x 133 x 25 | 25.1 | 203.2 | 133.2 | 5.7 | 7.8 | 7.6 | 172.4 |
| 203 x 133 x 30 | 30.0 | 206.8 | 133.9 | 6.4 | 9.6 | 7.6 | 172.4 |
| 254 x 102 x 22 | 22.0 | 254.0 | 101.6 | 5.7 | 6.8 | 7.6 | 225.2 |
| 254 x 102 x 25 | 25.2 | 257.2 | 101.9 | 6.0 | 8.4 | 7.6 | 225.2 |
| 254 x 102 x 28 | 28.3 | 260.4 | 102.2 | 6.3 | 10.0 | 7.6 | 225.2 |
| 254 x 146 x 31 | 31.1 | 251.4 | 146.1 | 6.0 | 8.6 | 7.6 | 219.0 |
| 254 x 146 x 37 | 37.0 | 256.0 | 146.4 | 6.3 | 10.9 | 7.6 | 219.0 |
| 254 x 146 x 43 | 43.0 | 259.6 | 147.3 | 7.2 | 12.7 | 7.6 | 219.0 |
| 305 x 102 x 25 | 24.8 | 305.1 | 101.6 | 5.8 | 7.0 | 7.6 | 275.9 |
| 305 x 102 x 28 | 28.2 | 308.7 | 101.8 | 6.0 | 8.8 | 7.6 | 275.9 |
| 305 x 102 x 33 | 32.8 | 312.7 | 102.4 | 6.6 | 10.8 | 7.6 | 275.9 |
| 305 x 127 x 37 | 37.0 | 304.4 | 123.4 | 7.1 | 10.7 | 8.9 | 265.2 |
| 305 x 127 x 42 | 41.9 | 307.2 | 124.3 | 8.0 | 12.1 | 8.9 | 265.2 |
| 305 x 127 x 48 | 48.1 | 311.0 | 125.3 | 9.0 | 14.0 | 8.9 | 265.2 |
| 305 x 165 x 40 | 40.3 | 303.4 | 165.0 | 6.0 | 10.2 | 8.9 | 265.2 |
| 305 x 165 x 46 | 46.1 | 306.6 | 165.7 | 6.7 | 11.8 | 8.9 | 265.2 |
| 305 x 165 x 54 | 54.0 | 310.4 | 166.9 | 7.9 | 13.7 | 8.9 | 265.2 |
| 356 x 171 x 45 | 45.0 | 351.4 | 171.1 | 7.0 | 9.7 | 12.7 | 306.6 |
| 356 x 171 x 51 | 51.0 | 355.0 | 171.5 | 7.4 | 11.5 | 12.7 | 306.6 |
| 356 x 171 x 57 | 57.0 | 358.0 | 172.2 | 8.1 | 13.0 | 12.7 | 306.6 |
| 356 x 171 x 67 | 67.1 | 363.4 | 173.2 | 9.1 | 15.7 | 12.7 | 306.6 |
| 406 x 140 x 39 | 39.0 | 398.0 | 141.8 | 6.4 | 8.6 | 12.7 | 355.4 |
| 406 x 140 x 46 | 46.0 | 403.2 | 142.2 | 6.8 | 11.2 | 12.7 | 355.4 |
| 406 x 140 x 53 | 53.3 | 406.6 | 143.3 | 7.9 | 12.9 | 12.7 | 355.4 |
| 406 x 178 x 54 | 54.1 | 402.6 | 177.7 | 7.7 | 10.9 | 12.7 | 355.4 |
| 406 x 178 x 60 | 60.1 | 406.4 | 177.9 | 7.9 | 12.8 | 12.7 | 355.4 |
| 406 x 178 x 67 | 67.1 | 409.4 | 178.8 | 8.8 | 14.3 | 12.7 | 355.4 |
| 406 x 178 x 74 | 74.2 | 412.8 | 179.5 | 9.5 | 16.0 | 12.7 | 355.4 |
| 406 x 178 x 85 | 85.3 | 417.2 | 181.9 | 10.9 | 18.2 | 12.7 | 355.4 |
| 457 x 152 x 52 | 52.3 | 449.8 | 152.4 | 7.6 | 10.9 | 12.7 | 402.6 |
| 457 x 152 x 60 | 59.8 | 454.6 | 152.9 | 8.1 | 13.3 | 12.7 | 402.6 |
| 457 x 152 x 67 | 67.2 | 458.0 | 153.8 | 9.0 | 15.0 | 12.7 | 402.6 |
| 457 x 152 x 74 | 74.2 | 462.0 | 154.4 | 9.6 | 17.0 | 12.7 | 402.6 |
| 457 x 152 x 82 | 82.1 | 465.8 | 155.3 | 10.5 | 18.9 | 12.7 | 402.6 |
| 457 x 191 x 67 | 67.1 | 453.4 | 189.9 | 8.5 | 12.7 | 12.7 | 402.6 |
| 457 x 191 x 74 | 74.3 | 457.0 | 190.4 | 9.0 | 14.5 | 12.7 | 402.6 |
| 457 x 191 x 82 | 82.0 | 460.0 | 191.3 | 9.9 | 16.0 | 12.7 | 402.6 |
| 457 x 191 x 89 | 89.3 | 463.4 | 191.9 | 10.5 | 17.7 | 12.7 | 402.6 |
| 457 x 191 x 98 | 98.3 | 467.2 | 192.8 | 11.4 | 19.6 | 12.7 | 402.6 |

3.1 UK SECTIONS

Universal Beams (continued)

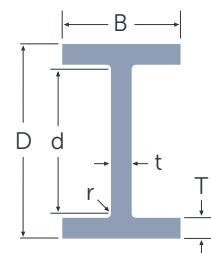

| Designation | Mass per metre | Depth of section | Width of section | Thickness | | Root radius | Depth between fillets |
|-----------------|----------------|------------------|------------------|-----------|-----------|-------------|-----------------------|
| | | | | of web | of flange | | |
| Serial size | kg/m | D | B | t | T | r | d |
| | | mm | mm | mm | mm | mm | mm |
| 457 x 191 x 106 | 105.8 | 469.2 | 194.0 | 12.6 | 20.6 | 12.7 | 402.6 |
| 457 x 191 x 133 | 133.3 | 480.6 | 196.7 | 15.3 | 26.3 | 12.7 | 402.6 |
| 457 x 191 x 161 | 161.4 | 492.0 | 199.4 | 18.0 | 32.0 | 12.7 | 402.6 |
| 457 x 280 x 113 | 113.0 | 463.0 | 280.0 | 10.8 | 17.3 | 20.0 | 388.4 |
| 457 x 280 x 128 | 128.0 | 467.0 | 282.0 | 12.2 | 19.6 | 20.0 | 387.8 |
| 457 x 280 x 144 | 144.0 | 472.0 | 283.0 | 13.6 | 22.1 | 20.0 | 387.8 |
| 457 x 280 x 158 | 158.0 | 476.0 | 284.0 | 15.0 | 23.9 | 20.0 | 388.2 |
| 457 x 280 x 177 | 177.0 | 482.0 | 286.0 | 16.6 | 26.9 | 20.0 | 388.2 |
| 457 x 280 x 193 | 193.0 | 489.0 | 283.0 | 17.0 | 30.5 | 20.0 | 388.0 |
| 457 x 280 x 213 | 213.0 | 495.0 | 285.0 | 18.5 | 33.5 | 20.0 | 388.0 |
| 457 x 280 x 235 | 235.0 | 501.0 | 287.0 | 20.6 | 36.6 | 20.0 | 387.8 |
| 457 x 280 x 260 | 260.0 | 509.0 | 289.0 | 22.6 | 40.4 | 20.0 | 388.2 |
| 457 x 280 x 286 | 286.0 | 517.0 | 291.0 | 24.4 | 44.4 | 20.0 | 388.2 |
| 457 x 280 x 315 | 315.0 | 525.0 | 293.0 | 26.9 | 48.5 | 20.0 | 388.0 |
| 533 x 165 x 66 | 65.7 | 524.7 | 165.1 | 8.9 | 11.4 | 12.7 | 476.5 |
| 533 x 165 x 74 | 74.7 | 529.1 | 165.9 | 9.7 | 13.6 | 12.7 | 476.5 |
| 533 x 165 x 85 | 84.8 | 534.9 | 166.5 | 10.3 | 16.5 | 12.7 | 476.5 |
| 533 x 210 x 82 | 82.2 | 528.3 | 208.8 | 9.6 | 13.2 | 12.7 | 476.5 |
| 533 x 210 x 92 | 92.1 | 533.1 | 209.3 | 10.1 | 15.6 | 12.7 | 476.5 |
| 533 x 210 x 101 | 101.0 | 536.7 | 210.0 | 10.8 | 17.4 | 12.7 | 476.5 |
| 533 x 210 x 109 | 109.0 | 539.5 | 210.8 | 11.6 | 18.8 | 12.7 | 476.5 |
| 533 x 210 x 122 | 122.0 | 544.5 | 211.9 | 12.7 | 21.3 | 12.7 | 476.5 |
| 533 x 210 x 138 | 138.3 | 549.1 | 213.9 | 14.7 | 23.6 | 12.7 | 476.5 |
| 533 x 312 x 150 | 150.6 | 542.5 | 312.0 | 12.7 | 20.3 | 12.7 | 476.5 |
| 533 x 312 x 165 | 165.0 | 546.0 | 313.0 | 14.0 | 22.2 | 12.7 | 476.2 |
| 533 x 312 x 182 | 181.5 | 550.7 | 314.5 | 15.2 | 24.4 | 12.7 | 476.5 |
| 533 x 312 x 196 | 196.0 | 554.0 | 316.0 | 16.5 | 26.3 | 12.7 | 476.0 |
| 533 x 312 x 219 | 218.7 | 560.3 | 317.4 | 18.3 | 29.2 | 12.7 | 476.5 |
| 533 x 312 x 248 | 248.0 | 571.0 | 315.0 | 19.0 | 34.5 | 12.7 | 476.6 |
| 533 x 312 x 272 | 273.2 | 577.1 | 320.2 | 21.1 | 37.6 | 12.7 | 476.5 |
| 610 x 178 x 82 | 81.8 | 598.6 | 177.9 | 10.0 | 12.8 | 20.0 | 533.0 |
| 610 x 178 x 92 | 92.2 | 603.0 | 178.8 | 10.9 | 15.0 | 20.0 | 533.0 |
| 610 x 178 x 100 | 100.3 | 607.4 | 179.2 | 11.3 | 17.2 | 20.0 | 533.0 |
| 610 x 229 x 101 | 101.2 | 602.6 | 227.6 | 10.5 | 14.8 | 20.0 | 533.0 |
| 610 x 229 x 113 | 113.0 | 607.6 | 228.2 | 11.1 | 17.3 | 20.0 | 533.0 |
| 610 x 229 x 125 | 125.1 | 612.2 | 229.0 | 11.9 | 19.6 | 20.0 | 533.0 |
| 610 x 229 x 140 | 139.9 | 617.2 | 230.2 | 13.1 | 22.1 | 20.0 | 533.0 |
| 610 x 305 x 149 | 149.2 | 612.4 | 304.8 | 11.8 | 19.7 | 20.0 | 533.0 |
| 610 x 305 x 179 | 179.0 | 620.2 | 307.1 | 14.1 | 23.6 | 20.0 | 533.0 |
| 610 x 305 x 238 | 238.1 | 635.8 | 311.4 | 18.4 | 31.4 | 20.0 | 533.0 |
| 610 x 324 x 155 | 155.0 | 611.0 | 324.0 | 12.7 | 19.0 | 20.0 | 533.0 |
| 610 x 324 x 174 | 174.0 | 616.0 | 325.0 | 14.0 | 21.6 | 20.0 | 532.8 |
| 610 x 324 x 195 | 195.0 | 622.0 | 327.0 | 15.4 | 24.4 | 20.0 | 533.2 |

3.1 UK SECTIONS

Universal Beams (continued)

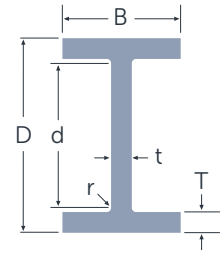

| Designation Serial size | Mass per metre kg/m | Depth of section D mm | Width of section B mm | Thickness | | Root radius r mm | Depth between fillets d mm |
|--------------------------------|----------------------------|---------------------------------|---------------------------------|-----------|-----------|----------------------------|--------------------------------------|
| | | | | of web | of flange | | |
| | | | | t mm | T mm | | |
| 610 x 324 x 217 | 217.0 | 628.0 | 328.0 | 16.5 | 27.7 | 20.0 | 532.6 |
| 610 x 324 x 241 | 241.0 | 635.0 | 329.0 | 17.9 | 31.0 | 20.0 | 533.0 |
| 610 x 324 x 262 | 262.0 | 641.0 | 327.0 | 19.0 | 34.0 | 20.0 | 533.0 |
| 610 x 324 x 285 | 285.0 | 647.0 | 329.0 | 20.6 | 37.1 | 20.0 | 532.8 |
| 610 x 324 x 307 | 307.0 | 653.0 | 330.0 | 22.1 | 39.9 | 20.0 | 533.2 |
| 610 x 324 x 341 | 341.0 | 661.0 | 333.0 | 24.4 | 43.9 | 20.0 | 533.2 |
| 610 x 324 x 372 | 372.0 | 669.0 | 335.0 | 26.4 | 48.0 | 20.0 | 533.0 |
| 686 x 254 x 125 | 125.2 | 677.9 | 253.0 | 11.7 | 16.2 | 20.0 | 605.5 |
| 686 x 254 x 140 | 140.1 | 683.5 | 253.7 | 12.4 | 19.0 | 20.0 | 605.5 |
| 686 x 254 x 152 | 152.4 | 687.5 | 254.5 | 13.2 | 21.0 | 20.0 | 605.5 |
| 686 x 254 x 170 | 170.2 | 692.9 | 255.8 | 14.5 | 23.7 | 20.0 | 605.5 |
| 686 x 254 x 192 | 192.6 | 702.0 | 254.0 | 15.5 | 27.9 | 20.0 | 606.2 |
| 762 x 267 x 134 | 133.9 | 750.0 | 264.4 | 12.0 | 15.5 | 20.0 | 679.0 |
| 762 x 267 x 147 | 146.9 | 754.0 | 265.2 | 12.8 | 17.5 | 20.0 | 679.0 |
| 762 x 267 x 161 | 161.0 | 758.0 | 266.0 | 13.8 | 19.3 | 20.0 | 679.4 |
| 762 x 267 x 173 | 173.0 | 762.2 | 266.7 | 14.3 | 21.6 | 20.0 | 679.0 |
| 762 x 267 x 185 | 185.0 | 766.0 | 267.0 | 14.9 | 23.6 | 20.0 | 678.8 |
| 762 x 267 x 197 | 196.8 | 769.8 | 268.0 | 15.6 | 25.4 | 20.0 | 679.0 |
| 838 x 292 x 176 | 175.9 | 834.9 | 291.7 | 14.0 | 18.8 | 20.0 | 757.3 |
| 838 x 292 x 194 | 193.8 | 840.7 | 292.4 | 14.7 | 21.7 | 20.0 | 757.3 |
| 838 x 292 x 210 | 210.0 | 846.0 | 293.0 | 15.4 | 24.4 | 20.0 | 757.2 |
| 838 x 292 x 226 | 226.5 | 850.9 | 293.8 | 16.1 | 26.8 | 20.0 | 757.3 |
| 838 x 292 x 252 | 250.7 | 859.0 | 292.1 | 17.0 | 31.0 | 20.0 | 757.0 |
| 914 x 305 x 201 | 200.9 | 903.0 | 303.3 | 15.1 | 20.2 | 19.1 | 824.4 |
| 914 x 305 x 224 | 224.2 | 910.4 | 304.1 | 15.9 | 23.9 | 19.1 | 824.4 |
| 914 x 305 x 238 | 238.3 | 915.0 | 305.0 | 16.5 | 25.9 | 19.1 | 825.0 |
| 914 x 305 x 253 | 253.4 | 918.4 | 305.5 | 17.3 | 27.9 | 19.1 | 824.4 |
| 914 x 305 x 271 | 271.0 | 923.0 | 307.0 | 18.4 | 30.0 | 19.1 | 824.8 |
| 914 x 305 x 289 | 289.1 | 926.6 | 307.7 | 19.5 | 32.0 | 19.1 | 824.4 |
| 914 x 305 x 313 | 313.0 | 932.0 | 309.0 | 21.1 | 34.5 | 19.1 | 824.8 |
| 914 x 305 x 345 | 345.1 | 943 | 308 | 22.1 | 39.9 | 19.1 | 825.0 |
| 914 x 305 x 381 | 381.5 | 950.7 | 310.3 | 24.4 | 43.9 | 20.0 | 822.9 |
| 914 x 419 x 343 | 343.3 | 911.8 | 418.5 | 19.4 | 32.0 | 24.1 | 799.6 |
| 914 x 419 x 365 | 365.0 | 916.0 | 419.4 | 20.3 | 34.3 | 24.1 | 799.2 |
| 914 x 419 x 388 | 388.0 | 921.0 | 420.5 | 21.4 | 36.6 | 24.1 | 799.6 |
| 1016 x 305 x 222 | 222.0 | 970.3 | 300.0 | 16.0 | 21.1 | 30.0 | 868.1 |
| 1016 x 305 x 249 | 248.7 | 980.1 | 300.0 | 16.5 | 26.0 | 30.0 | 868.1 |
| 1016 x 305 x 272 | 272.3 | 990.1 | 300.0 | 16.5 | 31.0 | 30.0 | 868.1 |
| 1016 x 305 x 314 | 314.3 | 999.9 | 300.0 | 19.1 | 35.9 | 30.0 | 868.1 |
| 1016 x 305 x 350 | 349.4 | 1008.0 | 302.0 | 21.1 | 40.0 | 30.0 | 868.0 |
| 1016 x 305 x 393 | 392.7 | 1015.9 | 303.0 | 24.4 | 43.9 | 30.0 | 868.1 |
| 1016 x 305 x 437 | 437.0 | 1026.1 | 305.4 | 26.9 | 49.0 | 30.0 | 868.1 |
| 1016 x 305 x 487 | 486.7 | 1036.3 | 308.5 | 30.0 | 54.1 | 30.0 | 868.1 |

3.1 UK SECTIONS

Universal Columns

Material to EN 10025-2

Nominal dimensions to EN 10365:2017 (where applicable)

Tolerance EN 10034:1993

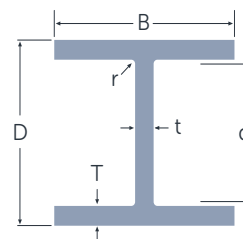

| Designation Serial size | Mass per metre kg/m | Depth of section D mm | Width of section B mm | Thickness | | Root radius r mm | Depth between fillets d mm |
|--------------------------------|----------------------------|---------------------------------|---------------------------------|-----------|-----------|----------------------------|--------------------------------------|
| | | | | of web | of flange | | |
| | | | | t mm | T mm | | |
| 152 x 152 x 23 | 23.0 | 152.4 | 152.2 | 5.8 | 6.8 | 7.6 | 123.6 |
| 152 x 152 x 30 | 30.0 | 157.6 | 152.9 | 6.5 | 9.4 | 7.6 | 123.6 |
| 152 x 152 x 37 | 37.0 | 161.8 | 154.4 | 8.0 | 11.5 | 7.6 | 123.6 |
| 152 x 152 x 44 | 44.0 | 166.0 | 155.9 | 9.5 | 13.6 | 7.6 | 123.6 |
| 152 x 152 x 51 | 51.2 | 170.2 | 157.4 | 11.0 | 15.7 | 7.6 | 123.6 |
| 203 x 203 x 46 | 46.1 | 203.2 | 203.6 | 7.2 | 11.0 | 12.7 | 155.8 |
| 203 x 203 x 52 | 52.0 | 206.2 | 204.3 | 7.9 | 12.5 | 12.7 | 155.8 |
| 203 x 203 x 60 | 60.0 | 209.6 | 205.8 | 9.4 | 14.2 | 12.7 | 155.8 |
| 203 x 203 x 71 | 71.0 | 215.8 | 206.4 | 10.0 | 17.3 | 12.7 | 155.8 |
| 203 x 203 x 86 | 86.1 | 222.2 | 209.1 | 12.7 | 20.5 | 12.7 | 155.8 |
| 203 x 203 x 100 | 99.6 | 228.6 | 210.3 | 14.5 | 23.7 | 12.7 | 155.8 |
| 203 x 203 x 113 | 113.5 | 235.0 | 212.1 | 16.3 | 26.9 | 12.7 | 155.8 |
| 203 x 203 x 127 | 127.5 | 241.4 | 213.9 | 18.1 | 30.1 | 12.7 | 155.8 |
| 254 x 254 x 73 | 73.1 | 254.1 | 254.6 | 8.6 | 14.2 | 20.0 | 185.7 |
| 254 x 254 x 81 | 81.0 | 256.0 | 255.0 | 9.4 | 15.6 | 20.0 | 184.8 |
| 254 x 254 x 89 | 88.9 | 260.3 | 256.3 | 10.3 | 17.3 | 20.0 | 185.7 |
| 254 x 254 x 101 | 101.0 | 264.0 | 257.0 | 11.9 | 19.6 | 20.0 | 184.8 |
| 254 x 254 x 107 | 107.1 | 266.7 | 258.8 | 12.8 | 20.5 | 20.0 | 185.7 |
| 254 x 254 x 115 | 115.0 | 269.0 | 259.0 | 13.5 | 22.1 | 20.0 | 184.8 |
| 254 x 254 x 132 | 132.0 | 276.3 | 261.3 | 15.3 | 25.3 | 20.0 | 185.7 |
| 254 x 254 x 149 | 149.0 | 282.0 | 263.0 | 17.3 | 28.4 | 20.0 | 185.2 |
| 254 x 254 x 167 | 167.1 | 289.1 | 265.2 | 19.2 | 31.7 | 20.0 | 185.7 |
| 305 x 305 x 97 | 96.9 | 307.9 | 305.3 | 9.9 | 15.4 | 20.0 | 237.1 |
| 305 x 305 x 107 | 107.0 | 311.0 | 306.0 | 10.9 | 17.0 | 20.0 | 237.0 |
| 305 x 305 x 118 | 117.9 | 314.5 | 307.4 | 12.0 | 18.7 | 20.0 | 237.1 |
| 305 x 305 x 129 | 129.0 | 318.0 | 308.0 | 13.1 | 20.6 | 20.0 | 236.8 |
| 305 x 305 x 137 | 136.9 | 320.5 | 309.2 | 13.8 | 21.7 | 20.0 | 237.1 |
| 305 x 305 x 143 | 143.0 | 323.0 | 309.0 | 14.0 | 22.9 | 20.0 | 237.2 |
| 305 x 305 x 158 | 158.1 | 327.1 | 311.2 | 15.8 | 25.0 | 20.0 | 237.1 |
| 305 x 305 x 179 | 179.0 | 333.0 | 313.0 | 18.0 | 28.1 | 20.0 | 236.8 |
| 305 x 305 x 198 | 198.1 | 339.9 | 314.5 | 19.1 | 31.4 | 20.0 | 237.1 |
| 305 x 305 x 202 | 202.0 | 341.0 | 315.0 | 20.1 | 31.8 | 20.0 | 237.4 |
| 305 x 305 x 226 | 226.0 | 348.0 | 317.0 | 22.1 | 35.6 | 20.0 | 236.8 |
| 305 x 305 x 240 | 240.0 | 352.5 | 318.4 | 23.0 | 37.7 | 20.0 | 237.1 |
| 305 x 305 x 253 | 253.0 | 356.0 | 319.0 | 24.4 | 39.6 | 20.0 | 236.8 |
| 305 x 305 x 283 | 282.9 | 365.3 | 322.2 | 26.8 | 44.1 | 20.0 | 237.1 |
| 356 x 368 x 129 | 129.0 | 355.6 | 368.6 | 10.4 | 17.5 | 20.0 | 280.6 |
| 356 x 368 x 134 | 134.0 | 356.0 | 369.0 | 11.2 | 18.0 | 20.0 | 280.0 |
| 356 x 368 x 147 | 147.0 | 360.0 | 370.0 | 12.3 | 19.8 | 20.0 | 280.4 |
| 356 x 368 x 153 | 152.9 | 362.0 | 370.5 | 12.3 | 20.7 | 20.0 | 280.6 |
| 356 x 368 x 162 | 162.0 | 364.0 | 371.0 | 13.3 | 21.8 | 20.0 | 280.4 |
| 356 x 368 x 177 | 177 | 368.2 | 372.6 | 14.4 | 23.8 | 20 | 280.6 |

3.1 UK SECTIONS

Universal Columns (continued)

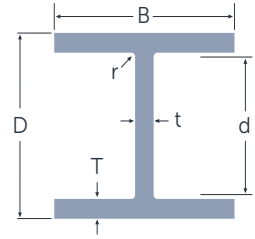

| Designation Serial size | Mass per metre kg/m | Depth of section D mm | Width of section B mm | Thickness | | Root radius r mm | Depth between fillets d mm |
|--------------------------------|----------------------------|---------------------------------|---------------------------------|-----------------------|--------------------------|----------------------------|--------------------------------------|
| | | | | of web t mm | of flange T mm | | |
| | | | | | | | |
| 356 x 368 x 179 | 179.0 | 368.0 | 374.0 | 15.0 | 23.9 | 20.0 | 280.2 |
| 356 x 368 x 196 | 196.0 | 372.0 | 374.0 | 16.4 | 26.2 | 20.0 | 279.6 |
| 356 x 368 x 202 | 201.9 | 374.6 | 374.7 | 16.5 | 27.0 | 20.0 | 280.6 |
| 356 x 406 x 216 | 216.0 | 375.0 | 394.0 | 17.3 | 27.7 | 20.0 | 279.6 |
| 356 x 406 x 235 | 235.1 | 381.0 | 394.8 | 18.4 | 30.2 | 20.0 | 280.6 |
| 356 x 406 x 237 | 237.0 | 380.0 | 395.0 | 18.9 | 30.2 | 20.0 | 279.6 |
| 356 x 406 x 262 | 262.0 | 387.0 | 398.0 | 21.1 | 33.3 | 20.0 | 280.4 |
| 356 x 406 x 287 | 287.1 | 393.6 | 399.0 | 22.6 | 36.5 | 20.0 | 280.6 |
| 356 x 406 x 314 | 314.0 | 399.0 | 401.0 | 24.9 | 39.6 | 20.0 | 279.8 |
| 356 x 406 x 340 | 339.9 | 406.4 | 403.0 | 26.6 | 42.9 | 20.0 | 280.6 |
| 356 x 406 x 347 | 347.0 | 407.0 | 404.0 | 27.2 | 43.7 | 20.0 | 279.6 |
| 356 x 406 x 382 | 382.0 | 416.0 | 406.0 | 29.8 | 48.0 | 20.0 | 280.0 |
| 356 x 406 x 393 | 393.0 | 419.0 | 407.0 | 30.6 | 49.2 | 20.0 | 280.6 |
| 356 x 406 x 421 | 421.0 | 425.0 | 409.0 | 32.8 | 52.6 | 20.0 | 279.8 |
| 356 x 406 x 463 | 463.0 | 435.0 | 412.0 | 35.8 | 57.4 | 20.0 | 280.2 |
| 356 x 406 x 467 | 467.0 | 436.6 | 412.2 | 35.8 | 58.0 | 20.0 | 280.6 |
| 356 x 406 x 509 | 509.0 | 446.0 | 416.0 | 39.1 | 62.7 | 20.0 | 280.6 |
| 356 x 406 x 551 | 551.0 | 455.6 | 418.5 | 42.1 | 67.5 | 20.0 | 280.6 |
| 356 x 406 x 592 | 592.0 | 465.0 | 421.0 | 45.0 | 72.3 | 20.0 | 280.4 |
| 356 x 406 x 634 | 633.9 | 474.6 | 424.0 | 47.6 | 77.0 | 20.0 | 280.6 |

3.1 UK SECTIONS

Universal Bearing Piles

Material to EN 10025-2
Nominal dimensions to EN 10365:2017 (where applicable)
Tolerance EN 10034:1993

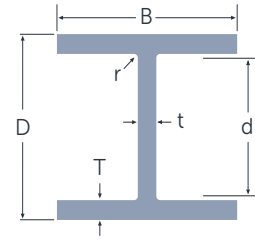

| Designation | Mass per metre | Depth of section | Width of section | Thickness | | Root radius | Depth between fillets |
|-----------------|----------------|------------------|------------------|-----------|-----------|-------------|-----------------------|
| | | | | of web | of flange | | |
| | | | | t | T | | |
| Serial size | kg/m | D | B | t | T | r | d |
| | | mm | mm | mm | mm | mm | mm |
| 203 x 203 x 45 | 44.9 | 200.2 | 205.9 | 9.5 | 9.5 | 10.2 | 160.8 |
| 203 x 203 x 54 | 53.9 | 204.0 | 207.7 | 11.3 | 11.4 | 10.2 | 160.8 |
| 254 x 254 x 63 | 63.0 | 247.1 | 256.6 | 10.6 | 10.7 | 20.0 | 185.7 |
| 254 x 254 x 71 | 71.0 | 249.7 | 258.0 | 12.0 | 12.0 | 20.0 | 185.7 |
| 254 x 254 x 85 | 85.1 | 254.3 | 260.4 | 14.4 | 14.3 | 20.0 | 185.7 |
| 305 x 305 x 79 | 78.9 | 299.3 | 306.4 | 11.0 | 11.1 | 20.0 | 237.1 |
| 305 x 305 x 88 | 88.0 | 301.7 | 307.8 | 12.4 | 12.3 | 20.0 | 237.1 |
| 305 x 305 x 95 | 94.9 | 303.7 | 308.7 | 13.3 | 13.3 | 20.0 | 237.1 |
| 305 x 305 x 110 | 110.0 | 307.9 | 310.7 | 15.3 | 15.4 | 20.0 | 237.1 |
| 305 x 305 x 126 | 126.1 | 312.3 | 312.9 | 17.5 | 17.6 | 20.0 | 237.1 |
| 305 x 305 x 149 | 149.1 | 318.5 | 316.0 | 20.6 | 20.7 | 20.0 | 237.1 |
| 305 x 305 x 186 | 186.0 | 328.3 | 320.9 | 25.5 | 25.6 | 2.0 | 273.1 |
| 305 x 305 x 223 | 222.9 | 337.9 | 325.7 | 30.3 | 30.4 | 20.0 | 237.1 |
| 356 x 368 x 109 | 108.9 | 346.4 | 371.0 | 12.8 | 12.9 | 20.0 | 280.6 |
| 356 x 368 x 133 | 133.0 | 352.0 | 373.8 | 15.6 | 15.7 | 20.0 | 280.6 |
| 356 x 368 x 152 | 152.0 | 356.4 | 376.0 | 17.8 | 17.9 | 20.0 | 280.6 |
| 356 x 368 x 174 | 173.9 | 361.4 | 378.5 | 20.3 | 20.4 | 20.0 | 280.6 |

3.1 UK SECTIONS

Parallel Flange Channels

Material to EN 10025-2
 Nominal dimensions to EN 10365:2017 (where applicable)
 Tolerance EN 10279:2000

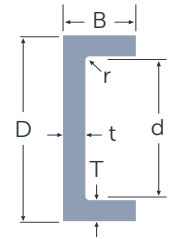

| Designation Serial size | Mass per metre kg/m | Depth of section D mm | Width of section B mm | Thickness | | Root radius r mm | Depth between fillets d mm |
|--------------------------------|----------------------------|---------------------------------|---------------------------------|-----------------------|--------------------------|----------------------------|--------------------------------------|
| | | | | of web t mm | of flange T mm | | |
| | | | | 150 x 75 x 18 | 17.9 | | |
| 150 x 90 x 24 | 23.9 | 150 | 90 | 6.5 | 12.0 | 12 | 102 |
| 180 x 75 x 20 | 20.3 | 180 | 75 | 6.0 | 10.5 | 12 | 135 |
| 180 x 90 x 26 | 26.1 | 180 | 90 | 6.5 | 12.5 | 12 | 131 |
| 200 x 75 x 23 | 23.4 | 200 | 75 | 6.0 | 12.5 | 12 | 151 |
| 200 x 90 x 30 | 29.7 | 200 | 90 | 7.0 | 14.0 | 12 | 148 |
| 230 x 75 x 26 | 25.7 | 230 | 75 | 6.5 | 12.5 | 12 | 181 |
| 230 x 90 x 32 | 32.2 | 230 | 90 | 7.5 | 14.0 | 12 | 178 |
| 260 x 75 x 28 | 27.6 | 260 | 75 | 7.0 | 12.0 | 12 | 212 |
| 260 x 90 x 35 | 34.8 | 260 | 90 | 8.0 | 14.0 | 12 | 208 |
| 300 x 90 x 41 | 41.4 | 300 | 90 | 9.0 | 15.5 | 12 | 245 |
| 300 x 100 x 46 | 45.5 | 300 | 100 | 9.0 | 16.5 | 15 | 237 |

3.1 UK SECTIONS

Asymmetric Beams

Material to EN 10025-2
Nominal dimensions as per table
Tolerance EN 10034:1993

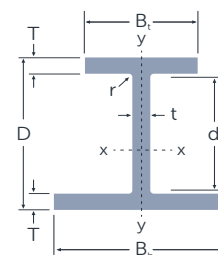

| Designation Serial size | Mass per metre kg/m | Depth of section D mm | Width of top flange B _t mm | Width of bottom flange B _b mm | Thickness | | Root radius r mm | Depth between fillets d mm |
|--------------------------------|----------------------------|---------------------------------|---|--|-----------|-----------|----------------------------|--------------------------------------|
| | | | | | of web | of flange | | |
| | | | | | t mm | T mm | | |
| 280 ASB 74 | 73.6 | 272 | 175 | 285 | 10 | 14 | 27 | 190 |
| 280 ASB 100* | 100.3 | 276 | 184 | 294 | 19 | 16 | 27 | 190 |
| 280 ASB 105 | 104.7 | 288 | 176 | 286 | 11 | 22 | 27 | 190 |
| 280 ASB 124 | 123.9 | 296 | 178 | 288 | 13 | 26 | 27 | 190 |
| 280 ASB 136* | 136.4 | 288 | 190 | 300 | 25 | 22 | 27 | 190 |
| 300 ASB 153* | 152.8 | 310 | 190 | 300 | 27 | 24 | 27 | 208 |
| 300 ASB 155 | 155.4 | 326 | 179 | 289 | 16 | 32 | 27 | 208 |
| 300 ASB 185* | 184.6 | 320 | 195 | 305 | 32 | 29 | 27 | 208 |
| 300 ASB 196 | 195.5 | 342 | 183 | 293 | 20 | 40 | 27 | 208 |
| 300 ASB 249* | 249.2 | 342 | 203 | 313 | 40 | 40 | 27 | 208 |

The elastic and plastic neutral axis position is measured from the upper surface of the beam

* These sections have been specifically developed with thicker webs for improved performance in fire

Unequal angles

Material to EN 10025-2
Nominal dimensions to EN 10056-1:2017 (where applicable)
Tolerance EN 10056-2:1993

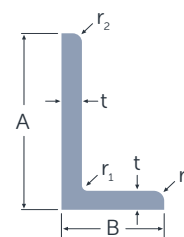

| Designation Serial size | Mass per metre | Depth of section | Width of section | Thickness of web | Root radius | Toe radius | Area of section |
|--------------------------------|----------------|------------------|------------------|------------------|----------------|----------------|-----------------|
| A x B x t | | h | b | s | r ₁ | r ₂ | cm ₂ |
| mm x mm x mm | kg/m | mm | mm | mm | mm | mm | |
| 200 x 100 x 10 | 23.0 | 200 | 100 | 10 | 15 | 7.5 | 29.2 |
| 200 x 100 x 12 | 27.3 | 200 | 100 | 12 | 15 | 7.5 | 34.8 |
| 200 x 100 x 15 | 33.7 | 200 | 100 | 15 | 15 | 7.5 | 43.0 |
| 200 x 150 x 12 | 32.0 | 200 | 150 | 12 | 15 | 7.5 | 40.8 |
| 200 x 150 x 15 | 39.6 | 200 | 150 | 15 | 15 | 7.5 | 50.5 |
| 200 x 150 x 18 | 47.1 | 200 | 150 | 18 | 15 | 7.5 | 60.0 |

The following sizes are rolled at our mill in Skinningrove:

| | | | | |
|----------------|-------|-----|-----|----|
| 200 x 100 x 10 | 23.0 | 200 | 100 | 10 |
| 200 x 100 x 12 | 27.3 | 200 | 100 | 12 |
| 200 x 100 x 13 | 29.5 | 200 | 100 | 13 |
| 200 x 100 x 14 | 31.7 | 200 | 100 | 14 |
| 200 x 100 x 15 | 33.81 | 200 | 100 | 15 |
| 200 x 100 x 16 | 35.93 | 200 | 100 | 16 |
| 200 x 150 x 12 | 32.0 | 200 | 150 | 12 |
| 200 x 150 x 13 | 34.59 | 200 | 150 | 13 |
| 200 x 150 x 15 | 39.59 | 200 | 150 | 15 |
| 200 x 150 x 18 | 47.09 | 200 | 150 | 18 |

3.1 UK SECTIONS

Equal angles

Material to EN 10025-2

Nominal dimensions to EN 10056-1:2017 (where applicable)

Tolerance EN 10056-2:1993

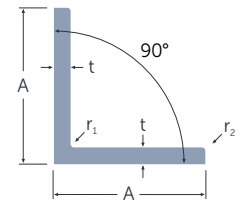

| Designation | Mass per metre | Depth of section | Width of section | Thickness | Root radius | Toe radius | Area of section |
|----------------|----------------|------------------|------------------|-----------|----------------|----------------|-----------------|
| Serial size | | | | | | | |
| A x A x t | | h | b | s | r ₁ | r ₂ | |
| mm x mm x mm | kg/m | mm | mm | mm | mm | mm | cm ₂ |
| 120 x 120 x 8 | 14.7 | 120 | 120 | 8 | 13 | 6.5 | 18.7 |
| 120 x 120 x 10 | 18.2 | 120 | 120 | 10 | 13 | 6.5 | 23.2 |
| 120 x 120 x 12 | 21.6 | 120 | 120 | 12 | 13 | 6.5 | 27.5 |
| 120 x 120 x 15 | 26.6 | 120 | 120 | 15 | 13 | 6.5 | 33.9 |
| 150 x 150 x 10 | 23.0 | 150 | 150 | 10 | 16 | 8.0 | 29.3 |
| 150 x 150 x 12 | 27.3 | 150 | 150 | 12 | 16 | 8.0 | 34.8 |
| 150 x 150 x 15 | 33.8 | 150 | 150 | 15 | 16 | 8.0 | 43.0 |
| 150 x 150 x 18 | 40.1 | 150 | 150 | 18 | 16 | 8.0 | 51.0 |
| 200 x 200 x 16 | 48.5 | 200 | 200 | 16 | 18 | 9.0 | 61.8 |
| 200 x 200 x 18 | 54.2 | 200 | 200 | 18 | 18 | 9.0 | 69.1 |
| 200 x 200 x 20 | 59.9 | 200 | 200 | 20 | 18 | 9.0 | 76.3 |
| 200 x 200 x 24 | 71.1 | 200 | 200 | 24 | 18 | 9.0 | 90.6 |

The following sizes are rolled at our mill in Skinninggrove:

| | | | | |
|------------------|-------|-----|-----|------|
| 200 x 200 x 14 | 42.7 | 200 | 200 | 14 |
| 200 x 200 x 15 | 45.7 | 200 | 200 | 15 |
| 200 x 200 x 16 | 48.5 | 200 | 200 | 16 |
| 200 x 200 x 17 | 51.4 | 200 | 200 | 17 |
| 200 x 200 x 18 | 54.2 | 200 | 200 | 18 |
| 200 x 200 x 19 | 57.1 | 200 | 200 | 19 |
| 200 x 200 x 20 | 59.9 | 200 | 200 | 20 |
| 200 x 200 x 22 | 65.6 | 200 | 200 | 22 |
| 200 x 200 x 23 | 68.4 | 200 | 200 | 23 |
| 200 x 200 x 24 | 71.1 | 200 | 200 | 24 |
| 200 x 200 x 25 | 73.9 | 200 | 200 | 25 |
| 200 x 200 x 26 | 76.6 | 200 | 200 | 26 |
| 200 x 200 x 28 | 82.0 | 200 | 200 | 28 |
| 200 x 200 x 28.6 | | 200 | 200 | 28.6 |
| 200 x 200 x 30 | 87.4 | 200 | 200 | 30 |
| 200 x 200 x 32 | | 200 | 200 | 32 |
| 200 x 200 x 34 | 98.0 | 200 | 200 | 34 |
| 250 x 250 x 24 | 90.0 | 250 | 250 | 24 |
| 250 x 250 x 25 | 93.5 | 250 | 250 | 25 |
| 250 x 250 x 26 | 97.6 | 250 | 250 | 26 |
| 250 x 250 x 27 | 100.5 | 250 | 250 | 27 |
| 250 x 250 x 28 | 104.0 | 250 | 250 | 28 |
| 250 x 250 x 32 | 118.0 | 250 | 250 | 32 |
| 250 x 250 x 35 | 128.0 | 250 | 250 | 35 |

3.1 UK SECTIONS

Equal angles (continued)

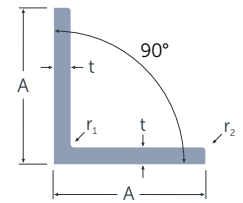

Imperial range (rolled at Skinningrove)

| Designation | Mass per metre | Depth of section | Width of section | Thickness of web | Root radius | Toe radius | Area of section |
|------------------|----------------|------------------|------------------|------------------|-------------|------------|-----------------|
| Serial size | | | | | | | |
| A x B x t | | h | b | s | r_1 | r_2 | |
| mm x mm x mm | kg/m | mm | mm | mm inches | mm | mm | cm ₂ |
| 203 x 203 x 12.7 | 39.3 | 203 | 203 | 12.7 1/2 | | | |
| 203 x 203 x 14.3 | | 203 | 203 | 14.3 9/16 | | | |
| 203 x 203 x 15.9 | 48.7 | 203 | 203 | 15.9 5/8 | | | |
| 203 x 203 x 19 | 57.9 | 203 | 203 | 19 3/4 | | | |
| 203 x 203 x 22.2 | 67.0 | 203 | 203 | 22.2 7/8 | | | |
| 203 x 203 x 25.4 | 75.9 | 203 | 203 | 25.4 1 | | | |
| 203 x 203 x 28.6 | 84.94 | 203 | 203 | 28.6 1 1/8 | | | |

3.2 AMERICAN --- SECTIONS



3.2 AMERICAN SECTIONS

American wide flange beams (W)

Material to ASTM A572 Grade 50 and ASTM A992
Nominal dimensions to ASTM A6 (where applicable)
Tolerance ASTM A6

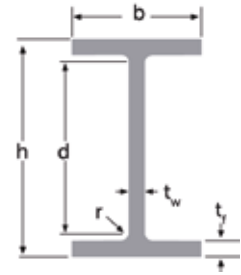

| Designation serial size | Mass per foot | ASTM metric equivalent | Depth of section | Width of section | Thickness | | Root radius | Depth between fillets |
|----------------------------|---------------------|---------------------------|---------------------|---------------------|----------------------|----------------------|-------------|-----------------------------|
| | | | | | of web | of flange | | |
| in | lb/ft | | h mm | b mm | t _w mm | t _f mm | r mm | d mm |
| W 6 x 6 | 15 | W 150 x 150 x 22.5 | 152 | 152 | 5.8 | 6.6 | 10.0 | 118.8 |
| W 6 x 6 | 20 | W 150 x 150 x 29.8 | 157 | 153 | 6.6 | 9.3 | 10.0 | 118.4 |
| W 6 x 6 | 25 | W 150 x 150 x 37.1 | 162 | 154 | 8.1 | 11.6 | 10.0 | 118.8 |
| W 8 x 5.25 | 18 | W 200 x 135 x 26.6 | 207 | 133 | 5.8 | 8.4 | 10.0 | 170.2 |
| W 8 x 5.25 | 21 | W 200 x 135 x 31.3 | 210 | 134 | 6.4 | 10.2 | 10.0 | 169.6 |
| W 8 x 8 | 31 | W 200 x 200 x 46.1 | 203 | 203 | 7.2 | 11.0 | 10.4 | 160.2 |
| W 8 x 8 | 35 | W 200 x 200 x 52 | 206 | 204 | 7.9 | 12.6 | 10.4 | 160.0 |
| W 8 x 8 | 40 | W 200 x 200 x 59 | 210 | 205 | 9.1 | 14.2 | 10.4 | 160.8 |
| W 8 x 8 | 48 | W 200 x 200 x 71 | 216 | 206 | 10.2 | 17.4 | 10.4 | 160.4 |
| W 8 x 8 | 58 | W 200 x 200 x 86 | 222 | 209 | 13.0 | 20.6 | 10.4 | 160.0 |
| W 8 x 8 | 67 | W 200 x 200 x 100 | 229 | 210 | 14.5 | 23.7 | 10.4 | 160.8 |
| W 8 x 8 | 76* | W 200 x 200 x 113 | 235 | 212.1 | 16.3 | 26.9 | 10.4 | 160.4 |
| W 8 x 8 | 86* | W 200 x 200 x 128 | 241.4 | 213.9 | 18.1 | 30.1 | 10.4 | 160.4 |
| W 10 x 4 | 15 | W 250 x 100 x 22.3 | 254 | 102 | 5.8 | 6.9 | 10.0 | 220.2 |
| W 10 x 4 | 17 | W 250 x 100 x 25.3 | 257 | 102 | 6.1 | 8.4 | 10.0 | 220.4 |
| W 10 x 4 | 19 | W 250 x 100 x 28.4 | 260 | 102 | 6.4 | 10.0 | 10.0 | 220.4 |
| W 10 x 5.75 | 22 | W 250 x 145 x 32.7 | 258 | 146 | 6.1 | 9.1 | 10.0 | 220.1 |
| W 10 x 5.75 | 26 | W 250 x 145 x 38.5 | 262 | 147 | 6.6 | 11.2 | 10.0 | 220.0 |
| W 10 x 5.75 | 30 | W 250 x 145 x 44.8 | 266 | 148 | 7.6 | 13.0 | 10.0 | 219.9 |
| W 10 x 10 | 49 | W 250 x 250 x 73 | 253 | 254 | 8.6 | 14.2 | 20.0 | 184.6 |
| W 10 x 10 | 54 | W 250 x 250 x 80 | 256 | 255 | 9.4 | 15.6 | 20.0 | 184.8 |
| W 10 x 10 | 60 | W 250 x 250 x 89 | 260 | 256 | 10.7 | 17.3 | 20.0 | 185.4 |
| W 10 x 10 | 68 | W 250 x 250 x 101 | 264 | 257 | 11.9 | 19.6 | 20.0 | 184.8 |
| W 10 x 10 | 72* | W 250 x 250 x 107 | 266.7 | 258.8 | 12.8 | 20.5 | 20.0 | 185.7 |
| W 10 x 10 | 77 | W 250 x 250 x 115 | 269 | 259 | 13.5 | 22.1 | 20.0 | 184.8 |
| W 10 x 10 | 88 | W 250 x 250 x 131 | 275 | 261 | 15.4 | 25.1 | 20.0 | 184.8 |
| W 10 x 10 | 100 | W 250 x 250 x 149 | 282 | 263 | 17.3 | 28.4 | 20.0 | 185.2 |
| W 10 x 10 | 112 | W 250 x 250 x 167 | 289 | 265 | 19.2 | 31.8 | 20.0 | 185.4 |
| W 12 x 4 | 16 | W 310 x 100 x 23.8 | 305 | 101 | 5.6 | 6.7 | 10.0 | 271.6 |
| W 12 x 4 | 19 | W 310 x 100 x 28.3 | 309 | 102 | 6.0 | 8.9 | 10.0 | 271.2 |
| W 12 x 4 | 22 | W 310 x 100 x 32.7 | 313 | 102 | 6.6 | 10.8 | 10.0 | 271.4 |
| W 12 x 12 | 65 | W 310 x 310 x 97 | 308 | 305 | 9.9 | 15.4 | 20.0 | 237.2 |
| W 12 x 12 | 72 | W 310 x 310 x 107 | 311 | 306 | 10.9 | 17.0 | 20.0 | 237.0 |
| W 12 x 12 | 79 | W 310 x 310 x 117 | 314 | 307 | 11.9 | 18.7 | 20.0 | 236.6 |
| W 12 x 12 | 87 | W 310 x 310 x 129 | 318 | 308 | 13.1 | 20.6 | 20.0 | 236.8 |
| W 12 x 12 | 92* | W 310 x 310 x 137 | 320.5 | 309.2 | 13.8 | 21.7 | 20.0 | 237.1 |
| W 12 x 12 | 96 | W 310 x 310 x 143 | 323 | 309 | 14.0 | 22.9 | 20.0 | 237.2 |
| W 12 x 12 | 106 | W 310 x 310 x 158 | 327 | 310 | 15.5 | 25.1 | 20.0 | 236.8 |
| W 12 x 12 | 120 | W 310 x 310 x 179 | 333 | 313 | 18.0 | 28.1 | 20.0 | 236.8 |
| W 12 x 12 | 133* | W 310 x 310 x 198 | 339.9 | 314.5 | 19.1 | 31.4 | 20.0 | 237.1 |
| W 12 x 12 | 136 | W 310 x 310 x 202 | 341 | 315 | 20.1 | 31.8 | 20.0 | 237.4 |
| W 12 x 12 | 152 | W 310 x 310 x 226 | 348 | 317 | 22.1 | 35.6 | 20.0 | 236.8 |

*Non-ASTM weight, but still offered by British Steel.

3.2 AMERICAN SECTIONS

American wide flange beams (W) (continued)

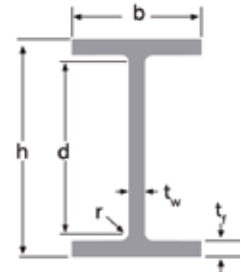

| Designation serial size | Mass per foot | ASTM metric equivalent | Depth of section | Width of section | Thickness | | Root radius | Depth between fillets |
|----------------------------|------------------|---------------------------|---------------------|---------------------|-----------|-----------|----------------------|-----------------------------|
| | | | | | of web | of flange | | |
| | | | in | lb/ft | h mm | b mm | t _w mm | t _f mm |
| W 12 x 12 | 161* | W 310 x 310 x 240 | 352.5 | 318.4 | 23.0 | 37.7 | 20.0 | 237.1 |
| W 12 x 12 | 170 | W 310 x 310 x 253 | 356 | 319 | 24.4 | 39.6 | 20.0 | 236.8 |
| W 12 x 12 | 190 | W 310 x 310 x 283 | 365 | 322 | 26.9 | 44.1 | 20.0 | 236.8 |
| W 14 x 6.75 | 30 | W 360 x 170 x 44.6 | 352 | 171 | 6.9 | 9.8 | 12.7 | 307 |
| W 14 x 6.75 | 34 | W 360 x 170 x 51 | 355 | 171 | 7.2 | 11.6 | 12.7 | 306.4 |
| W 14 x 6.75 | 38 | W 360 x 170 x 58 | 358 | 172 | 7.9 | 13.1 | 12.7 | 306.4 |
| W 14 x 6.75 | 45* | W 360 x 170 x 67 | 363.4 | 173.2 | 9.1 | 15.7 | 12.7 | 306.6 |
| W 14 x 14.5 | 87* | W 360 x 370 x 129 | 355.6 | 368.6 | 10.4 | 17.5 | 20.0 | 280.6 |
| W 14 x 14.5 | 90 | W 360 x 370 x 134 | 356 | 369 | 11.2 | 18.0 | 20.0 | 280 |
| W 14 x 14.5 | 99 | W 360 x 370 x 147 | 360 | 370 | 12.3 | 19.8 | 20.0 | 280.4 |
| W 14 x 14.5 | 103* | W 360 x 370 x 153 | 362 | 370.5 | 12.3 | 20.7 | 20.0 | 280.6 |
| W 14 x 14.5 | 109 | W 360 x 370 x 162 | 364 | 371 | 13.3 | 21.8 | 20.0 | 280.4 |
| W 14 x 14.5 | 119* | W 360 x 370 x 177 | 368.2 | 372.6 | 14.4 | 23.8 | 20.0 | 280.6 |
| W 14 x 14.5 | 120 | W 360 x 370 x 179 | 368 | 374 | 15.0 | 23.9 | 20.0 | 280.2 |
| W 14 x 14.5 | 132 | W 360 x 370 x 196 | 372 | 374 | 16.4 | 26.2 | 20.0 | 279.6 |
| W 14 x 14.5 | 136* | W 360 x 370 x 202 | 374.6 | 374.7 | 16.5 | 27.0 | 20.0 | 280.6 |
| W 14 x 16 | 145 | W 360 x 410 x 216 | 375 | 394 | 17.3 | 27.7 | 20.0 | 279.6 |
| W 14 x 16 | 158* | W 360 x 410 x 235 | 381 | 394.8 | 18.4 | 30.2 | 20.0 | 280.6 |
| W 14 x 16 | 159 | W 360 x 410 x 237 | 380 | 395 | 18.9 | 30.2 | 20.0 | 279.6 |
| W 14 x 16 | 176 | W 360 x 410 x 262 | 387 | 398 | 21.1 | 33.3 | 20.0 | 280.4 |
| W 14 x 16 | 193 | W 360 x 410 x 287 | 393 | 399 | 22.6 | 36.6 | 20.0 | 279.8 |
| W 14 x 16 | 211 | W 360 x 410 x 314 | 399 | 401 | 24.9 | 39.6 | 20.0 | 279.8 |
| W 14 x 16 | 228* | W 360 x 410 x 340 | 406.4 | 403 | 26.6 | 42.9 | 20.0 | 280.6 |
| W 14 x 16 | 233 | W 360 x 410 x 347 | 407 | 404 | 27.2 | 43.7 | 20.0 | 279.6 |
| W 14 x 16 | 257 | W 360 x 410 x 382 | 416 | 406 | 29.8 | 48.0 | 20.0 | 280 |
| W 14 x 16 | 264* | W 360 x 410 x 393 | 419 | 407 | 30.6 | 49.2 | 20.0 | 280.6 |
| W 14 x 16 | 283 | W 360 x 410 x 421 | 425 | 409 | 32.8 | 52.6 | 20.0 | 279.8 |
| W 14 x 16 | 311 | W 360 x 410 x 463 | 435 | 412 | 35.8 | 57.4 | 20.0 | 280.2 |
| W 14 x 16 | 314* | W 360 x 410 x 467 | 436.6 | 412.2 | 35.8 | 58.0 | 20.0 | 280.6 |
| W 14 x 16 | 320* | W 360 x 410 x 477 | 427 | 424.4 | 48.0 | 53.6 | 20.0 | 279.8 |
| W 14 x 16 | 342 | W 360 x 410 x 509 | 446 | 416 | 39.1 | 62.7 | 20.0 | 280.6 |
| W 14 x 16 | 370 | W 360 x 410 x 551 | 455 | 418 | 42.0 | 67.6 | 20.0 | 279.8 |
| W 14 x 16 | 398 | W 360 x 410 x 592 | 465 | 421 | 45.0 | 72.3 | 20.0 | 280.4 |
| W 14 x 16 | 426 | W 360 x 410 x 634 | 474 | 424 | 47.6 | 77.1 | 20.0 | 279.8 |
| W 16 x 5.5 | 26 | W 410 x 140 x 38.8 | 403 | 140 | 6.4 | 8.8 | 12.7 | 360 |
| W 16 x 5.5 | 31 | W 410 x 140 x 46.1 | 403 | 140 | 7.0 | 11.2 | 12.7 | 355.2 |
| W 16 x 5.5 | 35* | W 410 x 140 x 53 | 406.6 | 143.3 | 7.9 | 12.9 | 12.7 | 355.4 |
| W 16 x 7 | 36 | W 410 x 180 x 53 | 403 | 177 | 7.5 | 10.9 | 12.7 | 355.8 |
| W 16 x 7 | 40 | W 410 x 180 x 60 | 407 | 178 | 7.7 | 12.8 | 12.7 | 356 |
| W 16 x 7 | 45 | W 410 x 180 x 67 | 410 | 179 | 8.8 | 14.4 | 12.7 | 355.8 |
| W 16 x 7 | 50 | W 410 x 180 x 75 | 413 | 180 | 9.7 | 16.0 | 12.7 | 355.6 |
| W 16 x 7 | 57 | W 410 x 180 x 85 | 417.0 | 181.0 | 10.9 | 18.2 | 12.7 | 355.2 |

*Non-ASTM weight, but still offered by British Steel

3.2 AMERICAN SECTIONS

American wide flange beams (W) (continued)

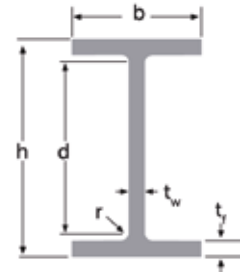

| Designation serial size | Mass per foot | ASTM metric equivalent | Depth of section | Width of section | Thickness | | Root radius | Depth between fillets |
|----------------------------|------------------|---------------------------|---------------------|---------------------|-----------|-----------|----------------------|-----------------------------|
| | | | | | of web | of flange | | |
| | | | in | lb/ft | h mm | b mm | t _w mm | t _f mm |
| W 18 x 6 | 35 | W 460 x 150 x 52 | 450 | 152 | 7.6 | 10.8 | 12.7 | 403 |
| W 18 x 6 | 40 | W 460 x 150 x 60 | 455 | 153 | 8.0 | 13.3 | 12.7 | 403 |
| W 18 x 6 | 46 | W 460 x 150 x 68 | 459 | 154 | 9.1 | 15.4 | 12.7 | 402.8 |
| W 18 x 6 | 50* | W 460 x 150 x 74 | 462 | 154.4 | 9.6 | 17.0 | 12.7 | 402.6 |
| W 18 x 6 | 55* | W 460 x 150 x 82 | 465.8 | 155.3 | 10.5 | 18.9 | 12.7 | 402.6 |
| W 18 x 7.5 | 45* | W 460 x 190 x 67 | 453.4 | 189.9 | 8.5 | 12.7 | 12.7 | 402.6 |
| W 18 x 7.5 | 50 | W 460 x 190 x 74 | 457 | 190 | 9.0 | 14.5 | 12.7 | 402.6 |
| W 18 x 7.5 | 55 | W 460 x 190 x 82 | 460 | 191 | 9.9 | 16.0 | 12.7 | 402.6 |
| W 18 x 7.5 | 60 | W 460 x 190 x 89 | 463 | 192 | 10.5 | 17.7 | 12.7 | 402.2 |
| W 18 x 7.5 | 65 | W 460 x 190 x 97 | 466 | 193 | 11.4 | 19.0 | 12.7 | 402.6 |
| W 18 x 7.5 | 71 | W 460 x 190 x 106 | 469 | 194 | 12.6 | 20.6 | 12.7 | 402.4 |
| W 18 x 7.5 | 89* | W 460 x 190 x 133 | 480.6 | 196.7 | 15.3 | 26.3 | 12.7 | 402.6 |
| W 18 x 7.5 | 108* | W 460 x 190 x 161 | 492 | 199.4 | 18.0 | 32.0 | 12.7 | 402.6 |
| W 18 x 11 | 76 | W 460 x 280 x 113 | 463 | 280 | 10.8 | 17.3 | 20.0 | 388.4 |
| W 18 x 11 | 86 | W 460 x 280 x 128 | 467 | 282 | 12.2 | 19.6 | 20.0 | 387.8 |
| W 18 x 11 | 97 | W 460 x 280 x 144 | 472 | 283 | 13.6 | 22.1 | 20.0 | 387.8 |
| W 18 x 11 | 106 | W 460 x 280 x 158 | 476 | 284 | 15.0 | 23.9 | 20.0 | 388.2 |
| W 18 x 11 | 119 | W 460 x 280 x 177 | 482 | 286 | 16.6 | 26.9 | 20.0 | 388.2 |
| W 18 x 11 | 130 | W 460 x 280 x 193 | 489 | 283 | 17.0 | 30.5 | 20.0 | 388 |
| W 18 x 11 | 143 | W 460 x 280 x 213 | 495 | 285 | 18.5 | 33.5 | 20.0 | 388 |
| W 18 x 11 | 158 | W 460 x 280 x 235 | 501 | 287 | 20.6 | 36.6 | 20.0 | 387.8 |
| W 18 x 11 | 175 | W 460 x 280 x 260 | 509 | 289 | 22.6 | 40.4 | 20.0 | 388.2 |
| W 18 x 11 | 192 | W 460 x 280 x 286 | 517 | 291 | 24.4 | 44.4 | 20.0 | 388.2 |
| W 18 x 11 | 211 | W 460 x 280 x 315 | 525 | 293 | 26.9 | 48.5 | 20.0 | 388 |
| W 21 x 6.5 | 44 | W 530 x 165 x 66 | 525 | 165 | 8.9 | 11.4 | 12.7 | 476.8 |
| W 21 x 6.5 | 50 | W 530 x 165 x 74 | 529 | 166 | 9.7 | 13.6 | 12.7 | 476.4 |
| W 21 x 6.5 | 57 | W 530 x 165 x 85 | 535 | 166 | 10.3 | 16.5 | 12.7 | 476.6 |
| W 21 x 8.25 | 55 | W 530 x 210 x 82 | 528 | 209 | 9.5 | 13.3 | 12.7 | 476 |
| W 21 x 8.25 | 62 | W 530 x 210 x 92 | 533 | 209 | 10.2 | 15.6 | 12.7 | 476.4 |
| W 21 x 8.25 | 68 | W 530 x 210 x 101 | 537 | 210 | 10.9 | 17.4 | 12.7 | 476.8 |
| W 21 x 8.25 | 73 | W 530 x 210 x 109 | 539 | 211 | 11.6 | 18.8 | 12.7 | 476 |
| W 21 x 8.25 | 83 | W 530 x 210 x 123 | 544 | 212 | 13.1 | 21.2 | 12.7 | 476.2 |
| W 21 x 8.25 | 93 | W 530 x 210 x 138 | 549 | 214 | 14.7 | 23.6 | 12.7 | 476.4 |
| W 21 x 12.25 | 101 | W 530 x 310 x 150 | 543 | 312 | 12.7 | 20.3 | 12.7 | 477 |
| W 21 x 12.25 | 111 | W 530 x 310 x 165 | 546 | 313 | 14.0 | 22.2 | 12.7 | 476.2 |
| W 21 x 12.25 | 122 | W 530 x 310 x 182 | 551 | 315 | 15.2 | 24.4 | 12.7 | 476.8 |
| W 21 x 12.25 | 132 | W 530 x 310 x 196 | 554 | 316 | 16.5 | 26.3 | 12.7 | 476 |
| W 21 x 12.25 | 147 | W 530 x 310 x 219 | 560 | 318 | 18.3 | 29.2 | 12.7 | 476.2 |
| W 21 x 12.25 | 166 | W 530 x 310 x 248 | 571 | 315 | 19.0 | 34.5 | 12.7 | 476.6 |
| W 21 x 12.25 | 182 | W 530 x 310 x 272 | 577 | 317 | 21.1 | 37.6 | 12.7 | 476.4 |
| W 24 x 7 | 55 | W 610 x 182 x 82 | 599 | 178 | 10.0 | 12.8 | 20.0 | 533.4 |
| W 24 x 7 | 62 | W 610 x 182 x 92 | 603 | 179 | 10.9 | 15.0 | 20.0 | 533 |

*Non-ASTM weight, but still offered by British Steel

3.2 AMERICAN SECTIONS

American wide flange beams (W) (continued)

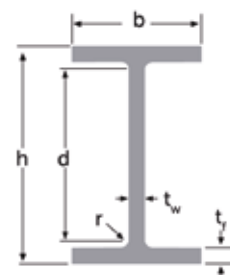

| Designation serial size | Mass per foot | ASTM metric equivalent | Depth of section | Width of section | Thickness | | Root radius | Depth between fillets |
|----------------------------|------------------|---------------------------|---------------------|---------------------|-----------|-----------|-------------|-----------------------------|
| | | | | | of web | of flange | | |
| | | | | | t_w | t_f | | |
| in | lb/ft | | h mm | b mm | mm | mm | r mm | d mm |
| W 24 x 7 | 67* | W 610 x 182 x 100 | 607 | 179.2 | 11.3 | 17.2 | 20.0 | 532.6 |
| W 24 x 9 | 68 | W 610 x 230 x 101 | 603 | 228 | 10.5 | 14.9 | 20.0 | 533.2 |
| W 24 x 9 | 76 | W 610 x 230 x 113 | 608 | 228 | 11.2 | 17.3 | 20.0 | 533.4 |
| W 24 x 9 | 84 | W 610 x 230 x 125 | 612 | 229 | 11.9 | 19.6 | 20.0 | 532.8 |
| W 24 x 9 | 94 | W 610 x 230 x 140 | 617 | 230 | 13.1 | 22.2 | 20.0 | 532.6 |
| W 24 x 12 | 100* | W610 x 300 x 149 | 612.4 | 304.8 | 11.8 | 19.7 | 20.0 | 533 |
| W 24 x 12 | 120* | W 610 x 300 x 179 | 620.2 | 307.1 | 14.4 | 23.6 | 20.0 | 533 |
| W 24 x 12 | 160* | W 610 x 300 x 238 | 635.8 | 311.4 | 18.4 | 31.4 | 20.0 | 533 |
| W 24 x 12.75 | 104 | W 610 x 325 x 155 | 611 | 324 | 12.7 | 19.0 | 20.0 | 533 |
| W 24 x 12.75 | 117 | W 610 x 325 x 174 | 616 | 325 | 14.0 | 21.6 | 20.0 | 532.8 |
| W 24 x 12.75 | 131 | W 610 x 325 x 195 | 622 | 327 | 15.4 | 24.4 | 20.0 | 533.2 |
| W 24 x 12.75 | 146 | W 610 x 325 x 217 | 628 | 328 | 16.5 | 27.7 | 20.0 | 532.6 |
| W 24 x 12.75 | 162 | W 610 x 325 x 241 | 635 | 329 | 17.9 | 31.0 | 20.0 | 533 |
| W 24 x 12.75 | 176 | W 610 x 325 x 262 | 641 | 327 | 19.0 | 34.0 | 20.0 | 533 |
| W 24 x 12.75 | 192 | W 610 x 325 x 285 | 647 | 329 | 20.6 | 37.1 | 20.0 | 532.8 |
| W 24 x 12.75 | 207 | W 610 x 325 x 307 | 653 | 330 | 22.1 | 39.9 | 20.0 | 533.2 |
| W 24 x 12.75 | 229 | W 610 x 325 x 341 | 661 | 333 | 24.4 | 43.9 | 20.0 | 533.2 |
| W 24 x 12.75 | 250 | W 610 x 325 x 372 | 669 | 335 | 26.4 | 48.0 | 20.0 | 533 |
| W 27 x 10 | 84 | W 690 x 250 x 125 | 678 | 253 | 11.7 | 16.3 | 20.0 | 605.4 |
| W 27 x 10 | 94 | W 690 x 250 x 140 | 684 | 254 | 21.4 | 18.9 | 20.0 | 606.2 |
| W 27 x 10 | 102 | W 690 x 250 x 152 | 688 | 254 | 13.1 | 21.1 | 20.0 | 605.8 |
| W 27 x 10 | 114 | W 690 x 250 x 170 | 693 | 256 | 14.5 | 23.6 | 20.0 | 605.8 |
| W 27 x 10 | 129 | W 690 x 250 x 192 | 702 | 254 | 15.5 | 27.9 | 20.0 | 606.2 |
| W 30 x 10.5 | 90 | W 760 x 265 x 134 | 750 | 264 | 11.9 | 15.5 | 20.0 | 679 |
| W 30 x 10.5 | 99 | W 760 x 265 x 147 | 753 | 265 | 13.2 | 17.0 | 20.0 | 679 |
| W 30 x 10.5 | 108 | W 760 x 265 x 161 | 758 | 266 | 13.8 | 19.3 | 20.0 | 679.4 |
| W 30 x 10.5 | 116 | W 760 x 265 x 173 | 762 | 267 | 14.4 | 21.6 | 20.0 | 678.8 |
| W 30 x 10.5 | 124 | W 760 x 265 x 185 | 766 | 267 | 14.9 | 23.6 | 20.0 | 678.8 |
| W 30 x 10.5 | 132 | W 760 x 265 x 196 | 770 | 268 | 15.6 | 25.4 | 20.0 | 679.2 |
| W 33 x 11.5 | 118 | W 840 x 295 x 176 | 835 | 292 | 14.0 | 18.8 | 20.0 | 757.4 |
| W 33 x 11.5 | 130 | W 840 x 295 x 193 | 840 | 292 | 14.7 | 21.7 | 20.0 | 756.6 |
| W 33 x 11.5 | 141 | W 840 x 295 x 210 | 846 | 293 | 15.4 | 24.4 | 20.0 | 757.2 |
| W 33 x 11.5 | 152 | W 840 x 295 x 226 | 851 | 294 | 16.1 | 26.8 | 20.0 | 757.4 |
| W 33 x 11.5 | 169 | W 840 x 295 x 251 | 859 | 292 | 17.0 | 31.0 | 20.0 | 757.0 |
| W 36 x 12 | 135 | W 920 x 310 x 201 | 903 | 304 | 15.2 | 20.1 | 19.1 | 824.6 |
| W 36 x 12 | 150 | W 920 x 310 x 223 | 911 | 304 | 15.9 | 23.9 | 19.1 | 825 |
| W 36 x 12 | 160 | W 920 x 310 x 238 | 915 | 305 | 16.5 | 25.9 | 19.1 | 825 |
| W 36 x 12 | 170 | W 920 x 310 x 253 | 919 | 306 | 17.3 | 27.9 | 19.1 | 825 |
| W 36 x 12 | 182 | W 920 x 310 x 271 | 923 | 307 | 18.4 | 30.0 | 19.1 | 824.8 |
| W 36 x 12 | 194 | W 920 x 310 x 289 | 927 | 308 | 19.4 | 32.0 | 19.1 | 824.8 |
| W 36 x 12 | 210 | W 920 x 310 x 313 | 932 | 309 | 21.1 | 34.5 | 19.1 | 824.8 |
| W 36 x 12 | 232 | W 920 x 310 x 345 | 943 | 308 | 22.1 | 39.9 | 19.1 | 825.0 |

*Non-ASTM weight, but still offered by British Steel

3.2 AMERICAN SECTIONS

American wide flange beams (W) (continued)

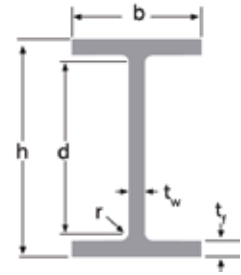

| Designation serial size | Mass per foot | ASTM metric equivalent | Depth of section | Width of section | Thickness | | Root radius | Depth between fillets |
|----------------------------|------------------|---------------------------|---------------------|---------------------|-----------|-----------|----------------------|-----------------------------|
| | | | | | of web | of flange | | |
| | | | in | lb/ft | h mm | b mm | t _w mm | t _f mm |
| W 36 x 12 | 256 | W 920 x 310 x 381 | 951 | 310 | 24.4 | 43.9 | 19.1 | 825.0 |
| W 36 x 16.5 | 231 | W 920 x 420 x 344 | 927 | 418 | 19.3 | 32.0 | 19.1 | 824.8 |
| W 36 x 16.5 | 247 | W 920 x 420 x 368 | 931 | 419 | 20.3 | 34.3 | 19.1 | 824.2 |
| W 36 x 16.5 | 262 | W 920 x 420 x 390 | 936 | 420 | 21.3 | 36.6 | 19.1 | 824.6 |
| W 36 x 16.5 | 282 | W 920 x 420 x 420 | 943 | 422 | 22.5 | 39.9 | 19.1 | 825 |
| W 40 x 12 | 149 | W 1000 x 300 x 222 | 970 | 300 | 16.0 | 21.1 | 30.0 | 867.8 |
| W 40 x 12 | 167 | W 1000 x 300 x 249 | 980 | 300 | 16.5 | 26.0 | 30.0 | 868 |
| W 40 x 12 | 183 | W 1000 x 300 x 272 | 990 | 300 | 16.5 | 31.0 | 30.0 | 868 |
| W 40 x 12 | 211 | W 1000 x 300 x 314 | 1000 | 300 | 19.1 | 35.9 | 30.0 | 868.2 |
| W 40 x 12 | 235 | W 1000 x 300 x 350 | 1008 | 302 | 21.1 | 40.0 | 30.0 | 868 |
| W 40 x 12 | 264 | W 1000 x 300 x 393 | 1016 | 303 | 24.4 | 43.9 | 30.0 | 868.2 |
| W 40 x 12 | 294 | W 1000 x 300 x 438 | 1026 | 305 | 26.9 | 49.0 | 30.0 | 868 |
| W 40 x 12 | 327 | W 1000 x 300 x 486 | 1036 | 308 | 30.0 | 54.1 | 30.0 | 867.8 |

*Non-ASTM weight, but still offered by British Steel

3.2 AMERICAN SECTIONS

American wide flange bearing piles (HP)

Material to ASTM A572 Grade 50 and ASTM A992
 Nominal dimensions to ASTM A6 (where applicable)
 Tolerance ASTM A6

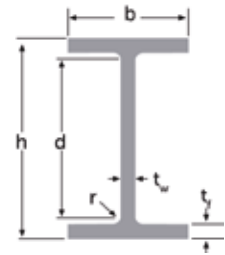

| Designation serial size | Mass per foot | ASTM metric equivalent | Depth of section | Width of section | Thickness | | Root radius | Depth between fillets |
|----------------------------|---------------------|---------------------------|---------------------|---------------------|-----------|-----------|-------------|-----------------------------|
| | | | | | of web | of flange | | |
| | | | | | t_w | t_f | | |
| in | lb/ft | | h | b | mm | mm | r | d |
| | | | mm | mm | mm | mm | mm | mm |
| HP 8 x 8 | 36 | HP 200 x 200 x 53 | 204 | 207.7 | 11.3 | 11.4 | 10.4 | 160.4 |
| HP 10 x 10 | 42 | HP 250 x 250 x 62 | 246 | 256 | 10.7 | 10.5 | 20 | 185.0 |
| HP 10 x 10 | 57 | HP 250 x 250 x 85 | 254 | 260 | 14.4 | 14.4 | 20 | 185.2 |
| HP 12 x 12 | 53 | HP 310 x 310 x 79 | 299 | 306 | 11.0 | 11.0 | 20 | 237.0 |
| HP 12 x 12 | 63 | HP 310 x 310 x 93 | 303 | 308 | 13.1 | 13.1 | 20 | 236.8 |
| HP 12 x 12 | 74 | HP 310 x 310 x 110 | 308 | 310 | 15.5 | 15.4 | 20 | 237.2 |
| HP 12 x 12 | 84 | HP 310 x 310 x 125 | 312 | 312 | 17.4 | 17.4 | 20 | 237.2 |
| HP 14 x 14.5 | 73 | HP 360 x 370 x 108 | 346 | 370 | 12.8 | 12.8 | 20 | 280.4 |
| HP 14 x 14.5 | 89 | HP 360 x 370 x 132 | 351 | 373 | 15.6 | 15.6 | 20 | 279.8 |
| HP 14 x 14.5 | 102 | HP 360 x 370 x 152 | 356 | 376 | 17.9 | 17.9 | 20 | 280.2 |
| HP 14 x 14.5 | 117 | HP 360 x 370 x 174 | 361 | 378 | 20.4 | 20.4 | 20 | 280.2 |

3.3 EUROPEAN SECTIONS



3.3 EUROPEAN SECTIONS

European I beams (IPE)

Material to EN 10025-2
Nominal dimensions to EN 10365:2017 (where applicable)
Tolerance EN 10034:1993

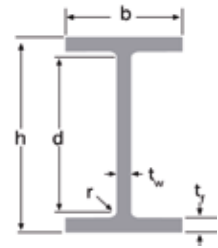

| Designation | Serial size | Mass per metre | Depth of section | Width of section | Thickness | | Root radius | Depth between fillets |
|---------------|-----------------|----------------|------------------|------------------|-----------|-----------|-------------|-----------------------|
| | | | | | of web | of flange | | |
| | | | | | t_w | t_f | | |
| | in | kg/m | h | b | mm | mm | r | d |
| | | | mm | mm | mm | mm | mm | mm |
| IPE 160 | 160 x 82 x 16 | 15.8 | 160.0 | 82.0 | 5.0 | 7.4 | 9.0 | 127.2 |
| IPE 180 | 180 x 91 x 19 | 18.8 | 180.0 | 91.0 | 5.3 | 8.0 | 9.0 | 146 |
| IPE 200 | 200 x 100 x 22 | 22.4 | 200.0 | 100.0 | 5.6 | 8.5 | 12.0 | 159 |
| IPE 220 | 220 x 110 x 26 | 26.2 | 220.0 | 110.0 | 5.9 | 9.2 | 12.0 | 177.6 |
| IPE 240 | 240 x 120 x 31 | 30.7 | 240.0 | 120.0 | 6.2 | 9.8 | 15.0 | 190.4 |
| IPE 270 | 270 x 135 x 36 | 36.1 | 270.0 | 135.0 | 6.6 | 10.2 | 15.0 | 219.6 |
| IPE 300 | 300 x 150 x 42 | 42.2 | 300.0 | 150.0 | 7.1 | 10.7 | 15.0 | 248.6 |
| IPE 400 | 400 x 180 x 66 | 66.3 | 400.0 | 180.0 | 8.6 | 13.5 | 20.0 | 333 |
| IPE 450 | 450 x 190 x 78 | 77.6 | 450.0 | 190.0 | 9.4 | 14.6 | 20.0 | 380.8 |
| IPE 500 | 500 x 200 x 91 | 90.7 | 500.0 | 200.0 | 10.2 | 16.0 | 20.0 | 428 |
| IPE 600 | 600 x 220 x 122 | 122.0 | 600.0 | 220.0 | 12.0 | 19.0 | 20.0 | 522 |
| IPE 750 x 134 | 762 x 267 x 134 | 133.9 | 750.0 | 264.0 | 12.0 | 15.5 | 20.0 | 679 |
| IPE 750 x 147 | 762 x 267 x 147 | 147.2 | 753.0 | 265.0 | 13.2 | 17.0 | 20.0 | 679 |
| IPE 750 x 173 | 762 x 267 x 173 | 173.7 | 762.0 | 267.0 | 14.4 | 21.6 | 20.0 | 678.8 |
| IPE 750 x 196 | 762 x 267 x 196 | 196.9 | 770.0 | 268.0 | 15.6 | 25.4 | 20.0 | 679.2 |

3.3 EUROPEAN SECTIONS

European wide flange beams (HE)

Material to EN 10025-2

Nominal dimensions to EN 10365:2017 (where applicable)

Tolerance EN 10034:1993

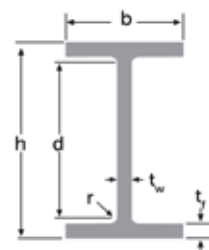

| Designation | Serial size | Mass per metre | Depth of section | Width of section | Thickness | | Root radius | Depth between fillets |
|-------------|------------------|----------------|------------------|------------------|-----------|-----------|-------------|-----------------------|
| | | | | | of web | of flange | | |
| | | | | | t_w | t_f | | |
| | in | kg/m | h mm | b mm | mm | mm | r mm | d mm |
| HE 120 A | 120 x 120 x 19.9 | 19.9 | 114.0 | 120.0 | 5.0 | 8.0 | 12.0 | 74 |
| HE 120 B | 120 x 120 x 26.7 | 26.7 | 120.0 | 120.0 | 6.5 | 11.0 | 12.0 | 74 |
| HE 120 M | 120 x 120 x 52.1 | 52.1 | 140.0 | 126.0 | 12.5 | 21.0 | 12.0 | 74 |
| HE 140 A | 140 x 140 x 24.7 | 24.7 | 133.0 | 140.0 | 5.5 | 8.5 | 12.0 | 92 |
| HE 140 B | 140 x 140 x 33.7 | 33.7 | 140.0 | 140.0 | 7.0 | 12.0 | 12.0 | 92 |
| HE 140 M | 140 x 140 x 63.2 | 63.2 | 160.0 | 146.0 | 13.0 | 22.0 | 12.0 | 92 |
| HE 160 A | 160 x 160 x 30.4 | 30.4 | 152.0 | 160.0 | 6.0 | 9.0 | 15.0 | 104 |
| HE 160 B | 160 x 160 x 42.6 | 42.6 | 160.0 | 160.0 | 8.0 | 13.0 | 15.0 | 104 |
| HE 160 M | 160 x 160 x 76.2 | 76.2 | 180.0 | 166.0 | 14.0 | 23.0 | 15.0 | 104 |
| HE 180 A | 180 x 180 x 36 | 35.5 | 171.0 | 180.0 | 6.0 | 9.5 | 16.0 | 120 |
| HE 180 B | 180 x 180 x 51 | 51.2 | 180.0 | 180.0 | 8.5 | 14.0 | 16.0 | 120 |
| HE 180 M | 180 x 180 x 89 | 88.9 | 200.0 | 186.0 | 14.5 | 24.0 | 16.0 | 120 |
| HE 200 A | 200 x 200 x 42 | 42.3 | 190.0 | 200.0 | 6.5 | 10.0 | 20.0 | 130 |
| HE 200 B | 200 x 200 x 61 | 61.3 | 200.0 | 200.0 | 9.0 | 15.0 | 20.0 | 130 |
| HE 200 M | 200 x 200 x 103 | 103.0 | 220.0 | 206.0 | 15.0 | 25.0 | 20.0 | 130 |
| HE 220 A | 220 x 220 x 51 | 50.5 | 210.0 | 220.0 | 7.0 | 11.0 | 20.0 | 148 |
| HE 220 B | 220 x 220 x 72 | 71.5 | 220.0 | 220.0 | 9.5 | 16.0 | 20.0 | 148 |
| HE 220 M | 220 x 220 x 117 | 117.0 | 240.0 | 226.0 | 15.5 | 26.0 | 20.0 | 148 |
| HE 240 A | 240 x 240 x 60 | 60.3 | 230.0 | 240.0 | 7.5 | 12.0 | 20.0 | 166 |
| HE 240 B | 240 x 240 x 83 | 83.2 | 240.0 | 240.0 | 10.0 | 17.0 | 20.0 | 166 |
| HE 240 M | 240 x 240 x 157 | 157.0 | 270.0 | 248.0 | 18.0 | 32.0 | 20.0 | 166 |
| HE 260 A | 260 x 260 x 68 | 68.2 | 250.0 | 260.0 | 7.5 | 12.5 | 20.0 | 185 |
| HE 260 B | 260 x 260 x 93 | 93.0 | 260.0 | 260.0 | 10.0 | 17.5 | 20.0 | 185 |
| HE 260 M | 260 x 260 x 172 | 172.0 | 290.0 | 268.0 | 18.0 | 32.5 | 20.0 | 185 |
| HE 280 A | 280 x 280 x 76 | 76.4 | 270.0 | 280.0 | 8.0 | 13.0 | 27.0 | 190 |
| HE 280 B | 280 x 280 x 103 | 103.0 | 280.0 | 280.0 | 10.5 | 18.0 | 27.0 | 190 |
| HE 280 M | 280 x 280 x 189 | 189.0 | 310.0 | 288.0 | 18.5 | 33.0 | 27.0 | 190 |
| HE 300 A | 300 x 300 x 88 | 88.3 | 290.0 | 300.0 | 8.5 | 14.0 | 27.0 | 208 |
| HE 300 B | 300 x 300 x 117 | 117.0 | 300.0 | 300.0 | 11.0 | 19.0 | 27.0 | 208 |
| HE 300 C | 300 x 300 x 177 | 177.0 | 320.0 | 305.0 | 16.0 | 29.0 | 27.0 | 208 |
| HE 300 M | 300 x 300 x 238 | 238.0 | 340.0 | 310.0 | 21.0 | 39.0 | 27.0 | 208 |
| HE 320 A | 320 x 300 x 98 | 97.6 | 310.0 | 300.0 | 9.0 | 15.5 | 27.0 | 225 |
| HE 320 B | 320 x 300 x 127 | 127.0 | 320.0 | 300.0 | 11.5 | 20.5 | 27.0 | 225 |
| HE 320 M | 320 x 300 x 245 | 245.0 | 359.0 | 309.0 | 12.0 | 40.0 | 27.0 | 225 |
| HE 340 A | 340 x 300 x 105 | 105.0 | 330.0 | 300.0 | 9.5 | 16.5 | 27.0 | 243 |
| HE 340 B | 340 x 300 x 134 | 134.0 | 340.0 | 300.0 | 12.0 | 21.5 | 27.0 | 243 |
| HE 340 M | 340 x 300 x 248 | 248.0 | 377.0 | 309.0 | 21.0 | 40.0 | 27.0 | 243 |
| HE 360 A | 360 x 300 x 112 | 112.0 | 350.0 | 300.0 | 10.0 | 17.5 | 27.0 | 261 |
| HE 360 B | 360 x 300 x 142 | 142.0 | 360.0 | 300.0 | 12.5 | 22.5 | 27.0 | 261 |

3.3 EUROPEAN SECTIONS

European wide flange beams (HE) (continued)

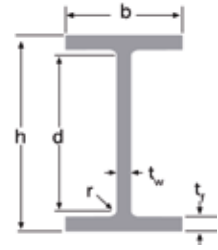

| Designation | Serial size | Mass per metre | Depth of section | Width of section | Thickness | | Root radius | Depth between fillets |
|-------------|------------------|----------------|------------------|------------------|-----------|-----------|-------------|-----------------------|
| | | | | | of web | of flange | | |
| | | | h | b | t_w | t_f | r | d |
| | in | kg/m | mm | mm | mm | mm | mm | mm |
| HE 360 M | 360 x 300 x 250 | 250.0 | 395.0 | 308.0 | 21.0 | 40.0 | 27.0 | 261.0 |
| HE 400 A | 400 x 300 x 125 | 125.0 | 390.0 | 300.0 | 11.0 | 19.0 | 27.0 | 298.0 |
| HE 400 B | 400 x 300 x 155 | 155.0 | 400.0 | 300.0 | 13.5 | 24.0 | 27.0 | 298.0 |
| HE 400 M | 400 x 300 x 256 | 256.0 | 432.0 | 307.0 | 21.0 | 40.0 | 27.0 | 298.0 |
| HE 450 A | 450 x 300 x 123 | 140.0 | 440.0 | 300.0 | 11.5 | 21.0 | 27.0 | 344.0 |
| HE 450 B | 450 x 300 x 171 | 171.0 | 450.0 | 300.0 | 14.0 | 26.0 | 27.0 | 344.0 |
| HE 450 M | 450 x 300 x 263 | 263.0 | 478.0 | 307.0 | 21.0 | 40.0 | 27.0 | 344.0 |
| HE 500 A | 500 x 300 x 155 | 155.0 | 490.0 | 300.0 | 12.0 | 23.0 | 27.0 | 390.0 |
| HE 500 B | 500 x 300 x 187 | 187.0 | 500.0 | 300.0 | 14.5 | 28.0 | 27.0 | 390.0 |
| HE 500 M | 500 x 300 x 270 | 270.0 | 524.0 | 306.0 | 21.0 | 40.0 | 27.0 | 390.0 |
| HE 550 A | 550 x 300 x 166 | 166.0 | 540.0 | 300.0 | 12.5 | 24.0 | 27.0 | 438.0 |
| HE 550 B | 550 x 300 x 199 | 199.0 | 550.0 | 300.0 | 15.0 | 29.0 | 27.0 | 438.0 |
| HE 550 M | 550 x 300 x 278 | 278.0 | 572.0 | 306.0 | 21.0 | 40.0 | 27.0 | 438.0 |
| HE 600 A | 600 x 300 x 178 | 178.0 | 590.0 | 300.0 | 13.0 | 25.0 | 27.0 | 486.0 |
| HE 600 B | 600 x 300 x 212 | 212.0 | 600.0 | 300.0 | 15.5 | 30.0 | 27.0 | 486.0 |
| HE 600 M | 600 x 300 x 285 | 285.0 | 620.0 | 305.0 | 21.0 | 40.0 | 27.0 | 486.0 |
| HE 650 A | 650 x 300 x 190 | 190.0 | 640.0 | 300.0 | 13.5 | 26.0 | 27.0 | 534.0 |
| HE 650 B | 650 x 300 x 225 | 225.0 | 650.0 | 300.0 | 16.0 | 31.0 | 27.0 | 534.0 |
| HE 650 M | 650 x 300 x 293 | 293.0 | 668.0 | 305.0 | 21.0 | 40.0 | 27.0 | 534.0 |
| HE 700 A | 700 x 300 x 204 | 204.0 | 690.0 | 300.0 | 14.5 | 27.0 | 27.0 | 582.0 |
| HE 700 B | 700 x 300 x 241 | 241.0 | 700.0 | 300.0 | 17.0 | 32.0 | 27.0 | 582.0 |
| HE 700 M | 700 x 300 x 301 | 301.0 | 716.0 | 304.0 | 21.0 | 40.0 | 27.0 | 582.0 |
| HE 800 A | 800 x 300 x 224 | 224.0 | 790.0 | 300.0 | 15.0 | 28.0 | 27.0 | 680.0 |
| HE 800 B | 800 x 300 x 262 | 262.0 | 800.0 | 300.0 | 17.5 | 33.0 | 27.0 | 680.0 |
| HE 800 M | 800 x 300 x 317 | 317.0 | 814.0 | 303.0 | 21.0 | 40.0 | 27.0 | 680.0 |
| HE 900 A | 900 x 300 x 252 | 252.0 | 890.0 | 300.0 | 16.0 | 30.0 | 30.0 | 770.0 |
| HE 900 B | 900 x 300 x 291 | 291.0 | 900.0 | 300.0 | 18.5 | 35.0 | 30.0 | 770.0 |
| HE 900 M | 900 x 300 x 333 | 333.0 | 910.0 | 305.0 | 21.0 | 40.0 | 30.0 | 770.0 |
| HE 1000 A | 1000 x 300 x 272 | 272.0 | 990.0 | 300.0 | 16.5 | 31.0 | 30.0 | 868.0 |
| HE 1000 B | 1000 x 300 x 314 | 314.0 | 1000.0 | 300.0 | 19.0 | 36.0 | 30.0 | 868.0 |
| HE 1000 M | 1000 x 300 x 349 | 349.0 | 1008.0 | 302.0 | 21.0 | 40.0 | 30.0 | 868.0 |

3.4 ADVANCE[®] SECTIONS

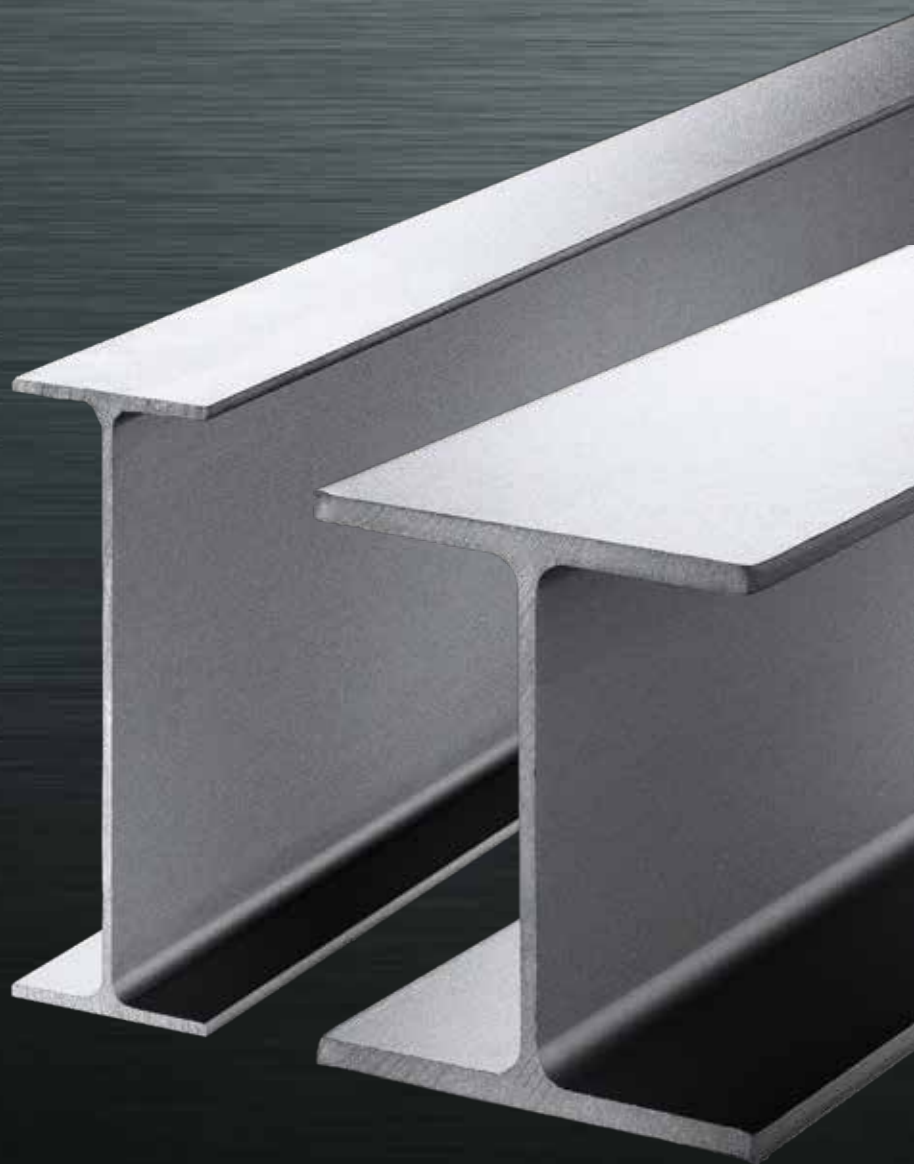

3.4 ADVANCE® SECTIONS

Our Advance® structural sections range provides greater design flexibility due to the inclusion of often difficult-to-find intermediary dimensions.

Our new Advance range has been extended by 71 additional beams and columns and is available in both standard grades and in our new premium S460M and weathering steel grades.

Initially developed to reflect structural design practice for CE-marked structural sections compliant with EU regulations, our new Advance range is also UKCA-marked in compliance with UK regulations on construction products.

Advance® universal beams

| Designation serial size | kg/m | Designation serial size | kg/m | Designation serial size | kg/m |
|-------------------------|-------|-------------------------|-------|-------------------------|-------|
| 254 x 102 x 28* | 28.3 | 457 x 280 x 128* | 128.0 | 610 x 324 x 241* | 241.0 |
| 305 x 102 x 33* | 32.8 | 457 x 280 x 113* | 113.0 | 610 x 324 x 217* | 217.0 |
| 305 x 102 x 28* | 28.2 | 533 x 165 x 85 | 84.8 | 610 x 324 x 195* | 195.0 |
| 305 x 127 x 48* | 48.1 | 533 x 165 x 74 | 74.7 | 610 x 324 x 174* | 174.0 |
| 305 x 127 x 42* | 41.9 | 533 x 165 x 66 | 65.7 | 610 x 324 x 155* | 155.0 |
| 406 x 140 x 53 | 53.3 | 533 x 210 x 138 | 138.3 | 686 x 254 x 192* | 192.6 |
| 406 x 178 x 85 | 85.3 | 533 x 312 x 272 | 273.2 | 686 x 254 x 170* | 170.2 |
| 457 x 152 x 82* | 82.1 | 533 x 312 x 248* | 248.0 | 686 x 254 x 152* | 152.4 |
| 457 x 152 x 74* | 74.2 | 533 x 312 x 219 | 218.7 | 762 x 267 x 197* | 196.8 |
| 457 x 191 x 161 | 161.4 | 533 x 312 x 196* | 196.0 | 762 x 267 x 185* | 185.0 |
| 457 x 191 x 133 | 133.3 | 533 x 312 x 182 | 181.5 | 762 x 267 x 161* | 161.0 |
| 457 x 191 x 106 | 105.8 | 533 x 312 x 165* | 165.0 | 838 x 292 x 252* | 250.7 |
| 457 x 280 x 315* | 315.0 | 533 x 312 x 150 | 150.6 | 838 x 292 x 210* | 210.0 |
| 457 x 280 x 286* | 286.0 | 610 x 178 x 100 | 100.3 | 914 x 305 x 381* | 381.5 |
| 457 x 280 x 260* | 260.0 | 610 x 178 x 92 | 92.2 | 914 x 305 x 345* | 345.0 |
| 457 x 280 x 235* | 235.0 | 610 x 178 x 82 | 81.8 | 914 x 305 x 313* | 313.0 |
| 457 x 280 x 213* | 213.0 | 610 x 324 x 372* | 372.0 | 914 x 305 x 271* | 271.0 |
| 457 x 280 x 193* | 193.0 | 610 x 324 x 341* | 341.0 | 914 x 305 x 239* | 238.3 |
| 457 x 280 x 177* | 177.0 | 610 x 324 x 307* | 307.0 | | |
| 457 x 280 x 158* | 158.0 | 610 x 324 x 285* | 285.0 | | |
| 457 x 280 x 144* | 144.0 | 610 x 324 x 262* | 262.0 | | |

Advance® universal columns

| Designation serial size | kg/m | Designation serial size | kg/m | Designation serial size | kg/m |
|-------------------------|-------|-------------------------|-------|-------------------------|-------|
| 152 x 152 x 51 | 51.2 | 305 x 305 x 202* | 202.0 | 356 x 406 x 509* | 509.0 |
| 152 x 152 x 44 | 44.0 | 305 x 305 x 179* | 179.0 | 356 x 406 x 463* | 463.0 |
| 203 x 203 x 127 | 127.5 | 305 x 305 x 143* | 143.0 | 356 x 406 x 421* | 421.0 |
| 203 x 203 x 113 | 113.5 | 305 x 305 x 129* | 129.0 | 356 x 406 x 382* | 382.0 |
| 203 x 203 x 100 | 99.6 | 305 x 305 x 107* | 107.0 | 356 x 406 x 347* | 347.0 |
| 254 x 254 x 149* | 149.0 | 356 x 368 x 196* | 196.0 | 356 x 406 x 314* | 314.0 |
| 254 x 254 x 115* | 115.0 | 356 x 368 x 179* | 179.0 | 356 x 406 x 262* | 262.0 |
| 254 x 254 x 101* | 101.0 | 356 x 368 x 162* | 162.0 | 356 x 406 x 237* | 237.0 |
| 254 x 254 x 81* | 81.0 | 356 x 368 x 147* | 147.0 | 356 x 406 x 216* | 216.0 |
| 305 x 305 x 253* | 253.0 | 356 x 368 x 134* | 134.0 | | |
| 305 x 305 x 226* | 226.0 | 356 x 406 x 592* | 592.0 | | |

*New sizes added to our Advance® range
A minimum order quantity of 20MT per section size (including kg/m) applies for Advance® universal beams and columns.

3.5 S460M

STRUCTURAL
SECTIONS

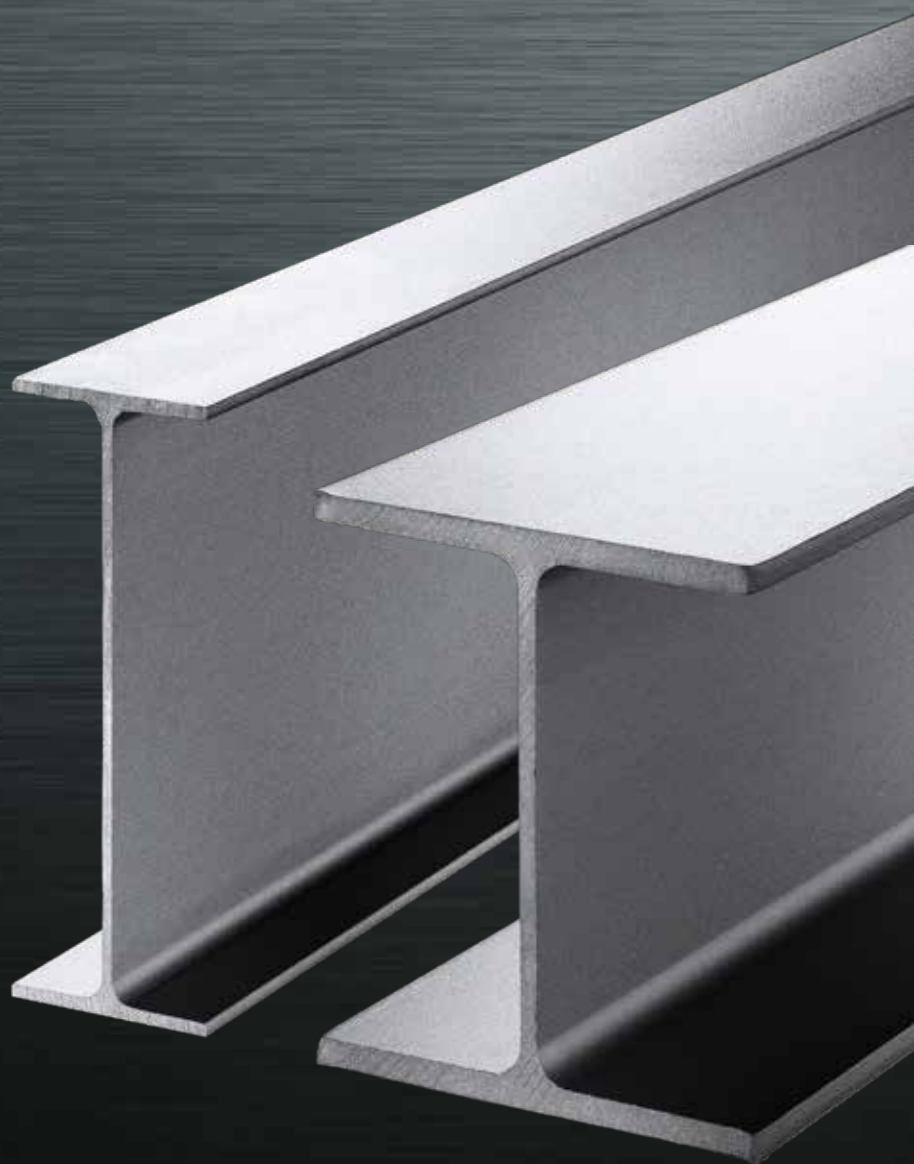

3.5 S460M HIGH-STRENGTH STRUCTURAL SECTIONS

High-strength S460M sections from British Steel deliver the optimum balance between cost and weight.

Manufactured in the UK to carefully controlled standards, our high-strength sections outperform existing steel grades through their higher tensile and yield strength.

Typical applications for this steel grade include multi-storey and high-rise buildings, as well as a wide range of other commercial and industrial uses.

Benefits of using high-strength S460M in your building:

- Cost reduction: less weight and lighter foundations reduce overall building costs
- Increased space: lighter sections will allow an increase in overall space within the building
- Lower embodied carbon: less carbon in direct proportion to the weight saving
- Reduced carbon emissions: less weight means less transport and less raw material consumption

Our S460 strength is achieved through microstructural engineering, so provides optimal results in thermal processes such as welding.

Mechanical properties

1. Tensile test

| Specification | Grade | Minimum yield strength (MPa) | | | | | | Tensile strength Rm (MPa) | | | | | Minimum elongation - A Lo = 5,65 √So (%) |
|---------------|-------|------------------------------|------------|------------|------------|-------------|--------------|---------------------------|------------|------------|-------------|--------------|---|
| | | Nominal thickness (mm) | | | | | | Nominal thickness (mm) | | | | | |
| | | ≤16 | >16 ≤40 | >40 ≤63 | >63 ≤80 | >80 ≤100 | >100 ≤125 | ≤40 | >40 ≤63 | >63 ≤80 | >80 ≤100 | >100 ≤125 | |
| EN 10025-4 | S460M | 460 | 440 | 430 | 410 | 400 | 385 | 540-720 | 530-710 | 510-690 | 500-680 | 490-660 | 17 |

2. Charpy-V notch impact test

| Test temperature °C | 20 | 0 | -10 | -20 |
|--|----|----|-----|-----|
| Minimum absorbed energy J (longitudinal) | 55 | 47 | 43 | 40 |

Chemical composition

| Specification | Grade | Chemical composition % by mass | | | | | | | | | | | | | | | | | | |
|---------------|-------|--------------------------------|------|------|------|-------|------|------|------|------|------|------|------|------|-------|------|------|------------|------------|-------------|
| | | min | | | | | | | | | | | | | | | CEV | | | |
| | | Al | C | Mn | Si | P | S | Nb | V | Ti | Cr | Mo | Ni | Cu | N | | | | | |
| | | | | | | | | | | | | | | | | | ≤16 | >16 ≤40 | >40 ≤63 | >63 ≤125 |
| EN 10025-4 | S460M | 0.02 | 0.18 | 1.70 | 0.60 | 0.035 | 0.03 | 0.05 | 0.12 | 0.05 | 0.30 | 0.20 | 0.80 | 0.55 | 0.025 | 0.45 | 0.45 | 0.46 | 0.47 | 0.48 |

High-strength structural sections size range

| Sizes | Universal beams | Universal columns | Universal bearing piles | Asymmetric beams |
|----------------------|------------------|-------------------|-------------------------|------------------|
| Ranging from: | 305 x 165 x 40 | 203 x 203 x 46 | 203 x 203 x 45 | 280 ASB |
| Up to and including: | 1016 x 305 x 487 | 356 x 406 x 634 | 356 x 368 x 174 | 300 ASB |

Ability to offer up to 80mm flange thickness.

A minimum order quantity of 20MT per section size (including kg/m) applies for universal beams, columns and bearing piles.

3.6 WEATHERING STEEL STRUCTURAL SECTIONS



3.6 WEATHERING STEEL STRUCTURAL SECTIONS

Weathering steel from British Steel offers an attractive and economic solution for many structures, including bridges, buildings and catenary gantries.

Self-protecting, durable and attractive, weathering steel is ideal for a whole range of outdoor structures in exposed locations.

Weathering steel is a high-strength, low alloy steel that defends itself from corrosion by forming a protective oxide patina, eliminating the need for paint or other protective coatings.

The steel's corrosion rate is so low that structures fabricated from unpainted weathering steel can achieve long lifespans – in some cases up to 120 years – with only minimal maintenance.

Benefits of using weathering steel in your project:

- Low maintenance: ideal for bridges and structures where access is difficult or dangerous
- Cost reduction: no need for protective painting and low maintenance reduces associated costs e.g. road or rail possession
- Environmental benefits: no volatile organic compounds from paint or disposal of blast-cleaning debris from future maintenance
- Attractive appearance: mature weathering steel often blends pleasingly with the environment, changing and improving with age
- Speed of construction: without site painting operations, overall construction time is reduced
- Enhanced safety: painting issues are eliminated and future maintenance risks are minimised such as welding

Mechanical properties

1. Tensile test

| Specification | Grade | Minimum yield strength (MPa) | | | | | | Tensile strength Rm (MPa) | | Minimum elongation - A | | | |
|---------------|-----------------------------------|------------------------------|------------|------------|------------|-------------|--------------|---------------------------|--------------|------------------------|------------|-------------|--------------|
| | | Nominal thickness (mm) | | | | | | Nominal thickness (mm) | | Lo = 5,65 √So (%) | | | |
| | | ≤16 | >16 ≤40 | >40 ≤63 | >63 ≤80 | >80 ≤100 | >100 ≤150 | >3 ≤100 | >100 ≤150 | >3 ≤40 | >40 ≤63 | >63 ≤100 | >100 ≤150 |
| EN 10025-5 | S355J0W, J2W, K2W, J4W, J5W | 355 | 345 | 335 | 325 | 315 | 295 | 470-630 | 450-600 | 22 | 21 | 20 | 18 |

2. Charpy-V notch impact test

| Grade | Temperature °C | Minimum energy KV ₂ ³ |
|---------|----------------|---|
| S355J0W | 0 | 27 |
| S355J2W | -20 | 27 |
| S355K2W | -20 | 40 |
| S355J4W | -40 | 27 |
| S355J5W | -50 | 27 |

3.6 WEATHERING STEEL STRUCTURAL SECTIONS

Chemical composition

| Specification | Grade | Chemical composition % by mass | | | | | | | | | |
|---------------|---------|--------------------------------|-------------|-------------|------|------|-----|-------|-------|-------|------|
| | | Mn | Cr | Cu | min | | max | | | | |
| | | | | | Al | C | Si | P | S | N | CEV |
| | S355J0W | 0.5 - 1.50 | 0.40 - 0.80 | 0.25 - 0.55 | 0.02 | 0.16 | 0.5 | 0.04 | 0.04 | 0.012 | 0.52 |
| | S355J2W | 0.5 - 1.50 | 0.40 - 0.80 | 0.25 - 0.55 | 0.02 | 0.16 | 0.5 | 0.035 | 0.035 | - | 0.52 |
| EN 10025-5 | S355K2W | 0.5 - 1.50 | 0.40 - 0.80 | 0.25 - 0.55 | 0.02 | 0.16 | 0.5 | 0.035 | 0.035 | - | 0.52 |
| | S355J4W | 0.5 - 1.50 | 0.40 - 0.80 | 0.25 - 0.55 | 0.02 | 0.16 | 0.5 | 0.035 | 0.025 | - | 0.52 |
| | S355J5W | 0.5 - 1.50 | 0.40 - 0.80 | 0.25 - 0.55 | 0.02 | 0.16 | 0.5 | 0.035 | 0.025 | - | 0.52 |

Weathering steel structural sections size range

| | Ranging from | Up to and including |
|-------------------------|----------------|---------------------|
| Universal beams | 356 x 171 x 45 | 1016 x 305 x 487 |
| Universal columns | 203 x 203 x 46 | 356 x 406 x 634 |
| Universal bearing piles | 203 x 203 x 45 | 356 x 368 x 174 |

Ability to offer up to 80mm flange thickness.

3.7 SERVICE CENTRES AND DISTRIBUTION FACILITIES



3.7 OUR SERVICE CENTRES AND DISTRIBUTION FACILITIES

We're committed to supplying customers with unrivalled service and innovative material solutions that are of real value.

Our service centres provide processing, service, distribution and sales support, whilst stocking a comprehensive range of key construction products, alongside our British Steel manufactured material.

Our Teesside Service Centre is a national hub for the processing and distribution of structural steel. Having benefited from significant investment, it is a truly unique facility, which is linked directly to our Teesside Beam Mill. Together, they offer superior co-ordination of production schedules and stock visibility, meaning improved product availability and shorter lead times.

Our Ireland Service Centre in Lisburn is equipped with large coil slitting and decoiling lines, together with saws and a shotblast/primer. This combination of local processing capability and an extensive range of stock ensures a flexible and responsive service.

Together, our best-in-class facilities offer an array of processing technologies:

- Cut-to-length
- Straight and mitre cutting
- Shotblasting
- Priming and painting



4 RAIL



ABOUT RAIL

Based in Scunthorpe since 2006, our rail manufacturing dates back to the mid-nineteenth century, when the first public railways were making a major impact on transport throughout the world.

Our innovations have included several world firsts including the Bessemer conversion method of steel production, continuous casting of rail steel and non-destructive testing technologies.

We work in partnership with rail customers to understand their demands and develop products that directly address their needs for more rail life with fewer maintenance requirements.

That means we play a central role in helping the rail industry rise to the challenges of higher traffic volumes, heavier axle loads and faster train speeds.

We provide a wide range of high performance rail products of up to 120m in length (or 216m in welded strings) to meet the needs of international high speed, heavy duty, mixed traffic, metro and tramway networks. These are supplied in accordance with directive 2008/57/EC for rail interoperability.

Our technical consultancy team is available to provide advice and support, helping customers to optimise their rail selections. Rail products and grades can be matched precisely to track conditions, track types, environmental conditions and a host of other variables to ensure that every rail we deliver provides optimum performance throughout its service life.



4.1 RAIL PROFILES AND GRADES



4.1 RAIL PROFILES AND GRADES

Dimensions, properties and compositions

The technical tables below show the range of rail profiles we manufacture in the UK.

These are available up to 120m long or 216m welded.

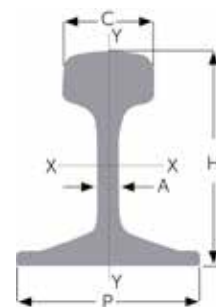

EN 13674-1 Flat bottom rails >46kg/m

| Rail profile | Equivalent profile name | Section weight kg/m | Rail height mm (H) | Head width mm (C) | Web thickness mm (A) | Foot width mm (P) | Moment of inertia I_{xx} cm ⁴ | Moment of inertia I_{yy} cm ⁴ |
|--------------|-------------------------|---------------------|--------------------|-------------------|----------------------|-------------------|--|--|
| 54E1 | UIC 54 | 54.77 | 159.00 | 70.00 | 16.00 | 140.00 | 2337.9 | 419.2 |
| 54E4 | – | 54.31 | 154.00 | 67.00 | 16.00 | 125.00 | 2056.2 | 352.7 |
| 56E1 | BS 113b | 56.3 | 158.75 | 69.85 | 20.00 | 140.00 | 2321.0 | 421.6 |
| 60E1 | UIC 60 | 60.21 | 172.00 | 72.00 | 16.50 | 150.00 | 3038.3 | 512.3 |
| 60E2 | – | 60.03 | 172.00 | 72.00 | 16.50 | 150.00 | 3021.5 | 510.5 |

EN 13674-4 Flat bottom rail 27kg/m to 46kg/m

| Rail profile | Equivalent profile name | Section weight kg/m | Rail height mm (H) | Head width mm (C) | Web thickness mm (A) | Foot width mm (P) | Moment of inertia I_{xx} cm ⁴ | Moment of inertia I_{yy} cm ⁴ |
|--------------|-------------------------|---------------------|--------------------|-------------------|----------------------|-------------------|--|--|
| 39E1 | BS 80A | 39.77 | 133.35 | 63.50 | 13.10 | 117.47 | 1204.9 | 219.6 |

Special rail sections

| Rail profile | Equivalent profile name | Section weight kg/m | Rail height mm (H) | Head width mm (C) | Web thickness mm (A) | Foot width mm (P) | Moment of inertia I_{xx} cm ⁴ | Moment of inertia I_{yy} cm ⁴ |
|--------------|-------------------------|---------------------|--------------------|-------------------|----------------------|-------------------|--|--|
| BS 95RBH | Bullhead | 47.07 | 145.26 | 69.85 | 19.05 | 69.85 | 1458.00 | 171.00 |
| Section 65* | Conductor | 65.41 | 102.00 | 89.00 | 70.00 | 70.00 | 677.04 | 483.57 |
| Section 75 | Conductor | 75.17 | 138.00 | 89.00 | 22.50 | 140.00 | 2163.93 | 891.66 |

*Available by agreement – please contact us to discuss your requirements.

Other rail profiles may be available – please contact us to discuss your requirements.

4.1 RAIL PROFILES AND GRADES

Rail application steel grades

The tables below indicate the typical steel compositions and mechanical properties for British Steel's rail application grades.

Flat bottom rail grades

| Specification | Grade | Chemical composition % by mass | | | | | | | | | Mechanical properties | | |
|---------------|------------------|--------------------------------|-----------|-----------|---------|-------------|-----------|---------|-----------|----------|-----------------------|----------------|---------------------|
| | | C | Si | Mn | P | S | Cr | Al | V | H2 (ppm) | Rm (MPa) | Elongation (%) | HBW running surface |
| UIC 860-R | 700 | 0.40-0.60 | 0.05-0.35 | 0.80-1.25 | ≤ 0.050 | ≤ 0.050 | – | – | – | – | 680-830 | ≥ 14 | – |
| | 900A | 0.60-0.80 | 0.10-0.50 | 0.80-1.30 | ≤ 0.040 | ≤ 0.040 | – | – | – | – | 880-1030 | ≥ 10 | – |
| | 900B | 0.55-0.75 | 0.10-0.50 | 1.30-1.70 | ≤ 0.040 | ≤ 0.040 | – | – | – | – | 880-1030 | ≥ 10 | – |
| EN 13674-1 | R200 | 0.40-0.60 | 0.15-0.58 | 0.70-1.20 | ≤ 0.035 | 0.008-0.035 | ≤ 0.15 | ≤ 0.004 | ≤ 0.03 | ≤ 3.0 | ≥ 680 | ≥ 14 | 200-240 |
| | R220 | 0.50-0.60 | 0.20-0.60 | 1.00-1.25 | ≤ 0.025 | 0.008-0.025 | ≤ 0.15 | ≤ 0.004 | ≤ 0.03 | ≤ 3.0 | ≥ 770 | ≥ 12 | 220-260 |
| | R260 | 0.62-0.80 | 0.15-0.58 | 0.70-1.20 | ≤ 0.025 | 0.008-0.025 | ≤ 0.15 | ≤ 0.004 | ≤ 0.03 | ≤ 2.5 | ≥ 880 | ≥ 10 | 260-300 |
| | R260Mn | 0.55-0.75 | 0.15-0.60 | 1.30-1.70 | ≤ 0.025 | 0.008-0.025 | ≤ 0.15 | ≤ 0.004 | ≤ 0.03 | ≤ 2.5 | ≥ 880 | ≥ 10 | 260-300 |
| IRS | 880 | 0.60-0.80 | 0.10-0.50 | 0.80-1.30 | ≤ 0.030 | ≤ 0.030 | – | ≤ 0.015 | – | ≤ 1.6 | ≥ 880 | ≥ 10 | ≥ 260 |
| British Steel | Premium: BLF320* | 0.10-0.30 | 0.80-1.80 | 1.20-1.80 | ≤ 0.025 | ≤ 0.025 | 0.30-0.80 | ≤ 0.004 | – | ≤ 2.0 | ≥ 950 | ≥ 12 | 340-380 |
| | Premium: HP335 | 0.87-0.97 | 0.75-1.00 | 0.75-1.00 | ≤ 0.020 | 0.008-0.020 | ≤ 0.10 | ≤ 0.004 | 0.09-0.13 | ≤ 2.5 | ≥ 1175 | ≥ 8 | 335-375 |

*Available by agreement – please contact us to discuss your requirements.

Conductor rail grade

| Specification | Grade | Chemical composition % by mass | | | | | | | | | Electrical properties |
|---------------|----------------|--------------------------------|--------|--------|--------|--------|----|----|---|----------|-----------------------|
| | | C | Si | Mn | P | S | Cr | Al | V | H2 (ppm) | Resistance (μΩ.cm) |
| BS 7865 | Conductor rail | ≤ 0.08 | ≤ 0.05 | ≤ 0.30 | ≤ 0.05 | ≤ 0.05 | – | – | – | – | <11.04 |

Other rail grades may be available – please contact us to discuss your requirements.

4.2 HP RANGE



4.2 HP RANGE

Excellent wear and RCF resistance

Our High Performance non heat-treated rails are our most wear-resistant grades:

- Designed for curved track and other high duty areas
- Metallurgically engineered to offer improved resistance to wear and rolling contact fatigue (RCF) compared to standard grade rail, greatly reducing the need for rail grinding and track maintenance
- Uniform through-hardness for consistent performance throughout the life of the rail
- Delivering extended rail life and reduced rail life cycle costs
- Our HP range meets all the quality, production and dimensional requirements set out in the EN 13674-1 standard for rails – the next revision of EN 13674-1 is due to include HP335 as a new grade, with the CEN technical committee working draft including HP335 under the name R335V
- HP335 can be supplied, by agreement, as HP350 with an enhanced hardness equivalent to that usually only found in heat treated rails – suitable for heavy duty freight lines

Mechanical properties

| Specification | Grade | Rm (MPa) | Elongation (%) | HBW running surface |
|---------------|-------|----------|----------------|---------------------|
| British Steel | HP335 | ≥ 1,150 | ≥ 8 | 335-375 |
| British Steel | HP350 | ≥ 1,175 | ≥ 8 | 350-390 |

Chemical composition

| Specification | Grade | C | Si | Mn | P | S | Cr | Al | V | H2 (ppm) |
|---------------|-----------------|---------------|---------------|---------------|---------|-----------------|--------|---------|---------------|----------|
| British Steel | HP335/ HP350 | 0.87- 0.97 | 0.75- 1.00 | 0.75- 1.00 | ≤ 0.020 | 0.008- 0.020 | ≤ 0.10 | ≤ 0.004 | 0.09- 0.13 | ≤ 2.5 |



4.3 ZINOCO®



4.3 ZINOCO®

Unbeatable corrosion protection

Our Zinoco® coated rail offers superior protection against corrosion for longer rail life.

Ideal for corrosive conditions e.g. tunnels, level crossings, salt pans and areas of stray current.

Developed in partnership with UK customer Network Rail who required a durable coating to withstand corrosion.

Zinoco offers 2 lines of defence:

- Durable barrier to combat corrosion
- Provides sacrificial protection, so still works if the coating is damaged

Zinoco coated rail protects against corrosion in the orange areas highlighted in the diagram below, enabling the rail to resist pitting, gall and general loss of section due to corrosion.

Currently being used by Network Rail (UK) and RATP (France), and approved for use by Irish Rail (Ireland) and London Underground (UK).

Performance against current competition

| Coating | Sacrificial protection | Stray current protection | Abrasion resistance | Impact resistance | Coating removal (for welding) |
|-----------------------|------------------------|--------------------------|---------------------|-------------------|-------------------------------|
| Zinoco® | Yes | Excellent | Excellent | Good | Moderate |
| Railcote® | Yes | Excellent | Moderate | Moderate | Easy |
| Aluminium metal spray | No | Poor | Very good | Good | Difficult/hazardous |
| Glass flake epoxy | No | Poor once damaged | Very poor | Very poor | Difficult/hazardous |
| Glass flake polyester | No | Poor once damaged | Poor | Poor | Difficult/hazardous |

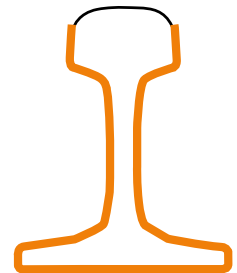

4.4 STEEL SLEEPERS



4.4 STEEL SLEEPERS

Lower lifetime costs with efficient logistics

Our steel sleepers are designed for use in all types of application, from metre gauge railways to mainline passenger and heavy haul routes.

They require less ballast than traditional concrete sleepers, leading to reduced track construction and renewal costs.

Once installed, steel sleepers don't rot or suffer from insect attacks. They also survive well in wet tropical climates where wood decays rapidly.

Being fully recyclable, our steel sleepers also benefit from a smaller carbon footprint, making it easier to hit your sustainability targets.

Steel sleepers are stackable and because they are lighter than concrete sleepers, can be moved in bundles by a forklift (or manually handled if regulations allow).

Often requiring only a third of the vehicle movements needed by concrete sleepers, using our steel sleepers helps to keep transportation costs to a minimum.

Our steel sleepers can be delivered with all fastening systems pre-installed, helping to keep your installation times to a minimum.

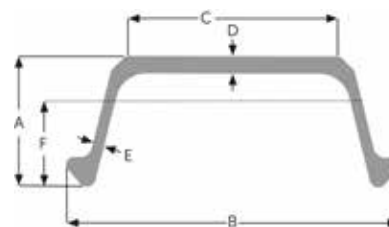

Steel sleeper dimensions

| Sleeper profile | Plate weight kg/m | Section height mm (A) | Section width mm (B) | Rail seat width mm (C) | Rail seat thickness mm (D) | Leg thickness mm (E) | Moment of inertia lxx cm ⁴ | Section modulus cm ³ | Height of neutral axis from base mm (F) |
|-----------------|-------------------|-----------------------|----------------------|------------------------|----------------------------|----------------------|---------------------------------------|---------------------------------|---|
| 202 | 22.10 | 82 | 240 | 160 | 7.5/12.0 | 6.75 | 200.0 | 34.4 | 58.1 |
| 300 | 28.36 | 92 | 254 | 160 | 12.0 | 7.0 | 283.3 | 42.3 | 67.0 |
| 402 | 28.54 | 100 | 260 | 168 | 10.0 | 7.0 | 426.0 | 62.8 | 67.1 |
| 436 | 31.69 | 100 | 260 | 168 | 12.0 | 7.0 | 432.8 | 65.8 | 68.4 |
| 600 | 39.53 | 115 | 280 | 168 | 14.5 | 7.6 | 654.7 | 81.3 | 80.5 |

Notes:

Can be supplied for all rail sizes and with the inclination required for your network.
Can be tailored to any rail gauge – 1,000mm, 1,067mm (3' 6"), standard and broadgauge.

Steel sleeper grade

| Specification | Grade | Chemical composition % by mass | | | | | | | | | Mechanical properties | |
|---------------|-------|--------------------------------|-----------|--------|---------|---------|----|---------|---|----------|-----------------------|----------------|
| | | C | Si | Mn | P | S | Cr | Al | V | H2 (ppm) | Rm (MPa) | Elongation (%) |
| EN 10025 | S275 | ≤ 0.21 | 0.14-0.25 | ≤ 1.50 | ≤ 0.035 | ≤ 0.035 | – | ≤ 0.008 | – | – | 410-560 | ≥ 23 |

A photograph showing five glowing, semi-finished metal rods in a furnace. The rods are arranged diagonally from the bottom left to the top right. They are bright yellow and orange, indicating they are at a high temperature. The background is a dark, industrial setting with some structural elements visible. The text "5 SEMI-FINISHED PRODUCTS" is overlaid in the upper left quadrant of the image.

5 SEMI-FINISHED
— PRODUCTS

ABOUT SEMI-FINISHED PRODUCTS

Our integrated steelmaking site at Scunthorpe produces a variety of semi-finished products to suit our customers' rolling requirements for long, structural or general engineering products.

Our steel is produced through the basic oxygen steelmaking (BOS) process, and can then be refined as appropriate in a ladle arc furnace and vacuum degasser facilities.

These processes control the steel temperatures and chemistries extremely tightly, ensuring our wide range of steel grades meet the most demanding customer requirements.

Our slabs, blooms and billets are continuously cast in sequences and the steel is fully shrouded between the ladle and the tundish and for slabs and blooms, between tundish and mould. Hood cooling may also be used for slabs and blooms to remove hydrogen, depending on the hydrogen content and specification required. On completion, our billets are identified to cast level, while blooms and slabs are uniquely-identified to ensure traceability.

British Steel is accredited to both ISO 9001:2015 for our quality management system and ISO 14001:2015 for our environmental management system. Our steelmaking and casting processes also hold ABS, BV, CCS, DNV, LRS and RINA shipbuilding accreditations.

In addition to verifying the chemical composition and segregation of our steel, we have well-equipped laboratories onsite where other tests can be conducted as required.



5.1 SLABS



5.1 SLABS

Our steel slabs are suitable for rolling to reversing mill plate, hot rolled coil and structural sections for a range of structural and general engineering applications.

Dimensions

| | Thickness | | | |
|-------|-----------|---------|-----|-----|
| | mm | | 225 | 298 |
| Width | | in | 9 | 12 |
| | 800 | 31 1/2 | | |
| | 1,095 | 43 1/8 | | |
| | 1,270 | 50 | | |
| | 1,425 | 56 1/8 | | |
| | 1,525 | 60 | | |
| | 1,540 | 60 5/8 | | |
| | 1,605 | 63 3/16 | | |
| | 1,820 | 71 2/3 | | |
| | 1,970 | 77 9/16 | | |

| Dimensions | Measurement |
|------------------|-------------|
| Length min | 6,900mm |
| Length max | 10,500mm |
| Piece weight max | 34.5t |

Documentation

Inspection certificates will be supplied for products being rolled in accordance with EN 10204, with the following elements being routinely analysed at cast level:

| Element | No. of reported digits after decimal point |
|--|--|
| C, Si, Mn | 2 |
| P, S, Al(t), V, Ti, Nb, Sn, Mo, Co, Ca, Cu, Ni, Cr, N ₂ | 3 |
| B | 4 |

Bespoke slabs for your rolling needs

Our slabs can be tailored to best meet the attributes of your products and help you meet the appropriate national and international standards. Please contact us to discuss your requirements.

| Application | Standard |
|----------------------------|---|
| Structural steel | Suitable for rolling to EN 10025 e.g. S235, S275, S355 |
| Structural steel | Suitable for rolling to ASTM e.g. A36, A992, A572 gr 50 |
| Low carbon hot rolled coil | Suitable for rolling to EN 10111 |

5.1 SLABS

Tolerances

| Tolerance | Measurement (all section sizes) |
|-----------|--|
| Thickness | + / - 5mm |
| Width | + / - 20mm (last in sequence + 20mm / - 45mm) |
| Length* | + / - 100mm |

Notes:

*Shorts allowance up to 3 pieces per strand per sequence.

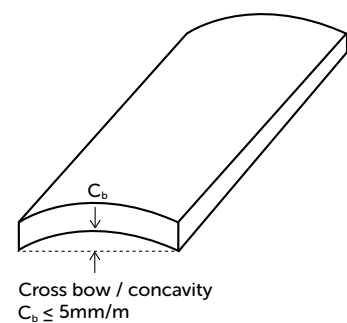
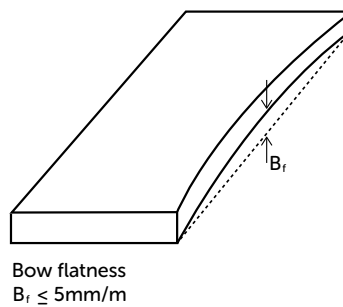
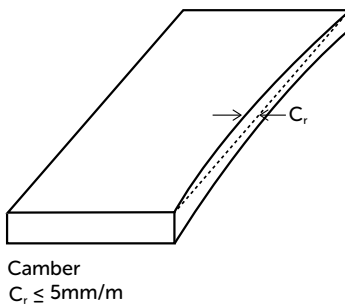
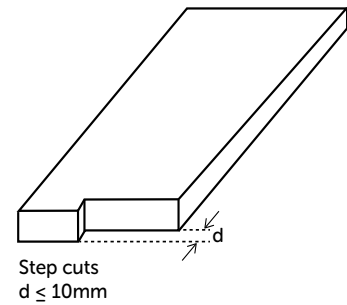
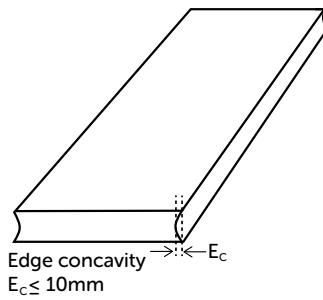
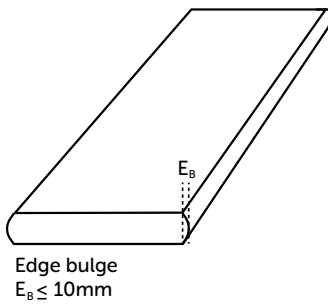
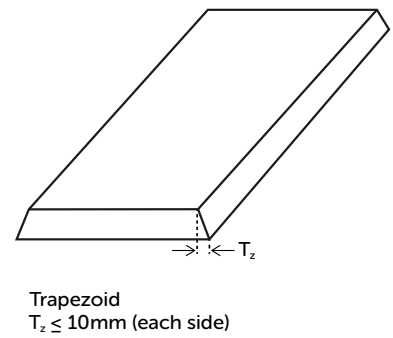
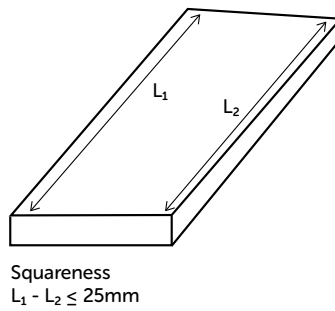
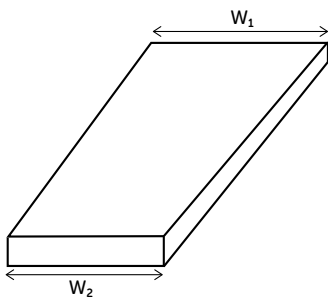
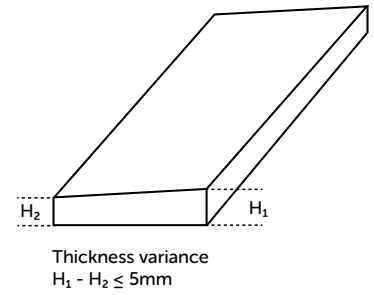
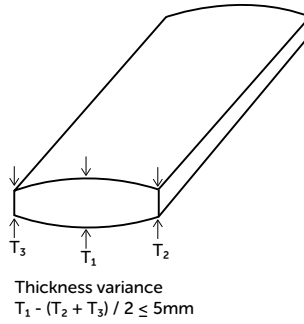

Quantity

Nominal order in 280 metric tonne multiples. Overall order quantity + / - 10%.

5.2 BLOOMS



5.2 BLOOMS

Our steel blooms have a rectangular cross-section and are suitable for structural, rail and wire rod applications.

Surface quality

Blooms are supplied in 'as-cast' condition with normal levels of scale. Superficial surface corrosion may occur during storage and shipping. The external surface will be free from longitudinal and transverse cracks, slivers, corrugation, gas cavities and slag inclusions.

Blooms are flame-cut to length.

Internal quality

Blooms will be free from excessive segregation, pipe, internal laminations, slag inclusions and blowholes.

Dimensions

| | | Thickness (mm) | | |
|------------|-----|----------------|-----|-----|
| | | 231 | 254 | 309 |
| Width (mm) | 283 | | | |
| | 330 | | | |
| | 360 | | | |
| | 486 | | | |
| | | | | |

| Dimensions | Measurement (mm) |
|------------|------------------|
| Length min | 4,000 |
| Length max | 9,600 |

Notes:

Individual bloom weights are calculated from the declared dimensions.

Tolerances

Size

| Tolerance | Measurement (all section sizes) |
|-----------|---------------------------------|
| Thickness | + / - 8mm |
| Width | + / - 8mm |
| Length* | + / - 120mm |

Notes:

*Shorts allowance up to 5% of blooms down to customers' minimum length.

Shape

| Tolerance | Measurement (all section sizes) |
|-----------------------|---|
| Bloom straightness | 0.5% of length |
| Rhomboidity | 10mm of nominal length diagonal |
| Twist | 1° max per metre with max 4° per length |
| Concavity / convexity | + / - 1.5% of thickness and width max |
| Cut straightness | 3% of length of cut |

Notes:

These features are not measured on a regular basis but standard caster output is within the above tolerances. Incidents which lead to a deterioration in quality of caster output would prompt investigation into suitability of cast product for intended orders.

5.2 BLOOMS

Bloom ends

Blooms will be supplied 'as-cut' with flame cut ends.

| Cutting fin | mm |
|-------------|--------|
| Width | ≤ 20mm |
| Thickness | ≤ 10mm |

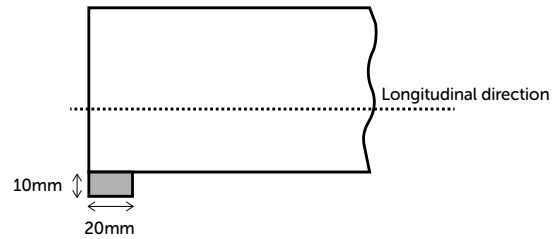

Quantity

Nominal order in 280 metric tonne multiples. Overall order quantity + / - 10%.

Documentation

Inspection certificates will be supplied for products being rolled in accordance with EN 10204, with the following elements being routinely analysed at cast level:

| Element | No. of reported digits after decimal point |
|--|--|
| C, Si, Mn | 2 |
| P, S, Al(t), V, Ti, Nb, Sn, Mo, Co, Ca, Cu, Ni, Cr, N ₂ | 3 |
| B | 4 |

Bespoke blooms for your rolling needs

Our blooms can be tailored to best meet the attributes of your products and help you meet the appropriate national and international standards. Please contact us to discuss your requirements.

| Application | Standard |
|------------------|---|
| Structural steel | Suitable for rolling to EN 10025 e.g. S235, S275, S355 |
| Structural steel | Suitable for rolling to ASTM e.g. A36, A992, A572 gr 50 |



5.3 BILLETS



5.3 BILLETS

Our steel billets have a square cross-section and are suitable for steel-reinforcement, structural, low-carbon and drawing applications.

Dimensions

| Dimension | Measurement (mm) |
|---------------------|------------------|
| Width and thickness | 140 x 140 |
| Width and thickness | 180 x 180 |

| Dimension | Measurement (mm) |
|------------|------------------|
| Length min | 8,000 |
| Length max | 14,000 |

Tolerances

Section overall

Measure section mid-face S1 and S2 (preferred method)

| Section | mm |
|---------|-----------|
| 140mm | - 3 / + 5 |
| 180mm | -2 / + 6 |

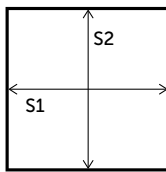

Rhomboidity

Measure diagonal D1 and D2
Diagonal difference D1 - D2

| Section | Measurement |
|---------|-------------|
| 140mm | 10mm max |
| 180mm | 14mm max |
| All | 3° max |

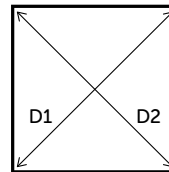

| Tolerance | Measurement (all section sizes) |
|----------------|---------------------------------------|
| Length* | + / - 100mm |
| Straightness** | 10mm/m or 100mm max on overall length |

Notes:

*Shorts allowance up to 5% of billets down to customers' minimum length.

**Measure gap from flat surface or wire stretched end-to-end.

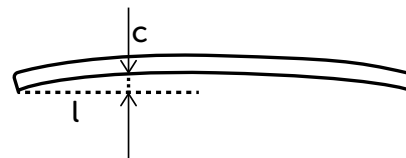
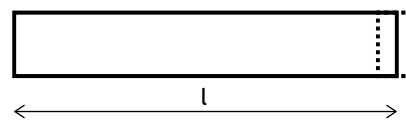

5.3 BILLETS

| Tolerance | Measurement (all section sizes) |
|---------------------------|---|
| Twist | 3° max on overall length |
| Fash / flame cutting burr | x = 10mm max |
| Corner radius | r = 4mm |
| Quantity | Nominal order in 280 metric tonne multiples Overall order quantity + / - 10% |

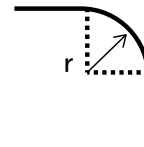
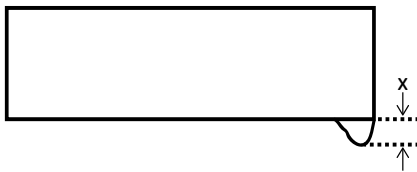
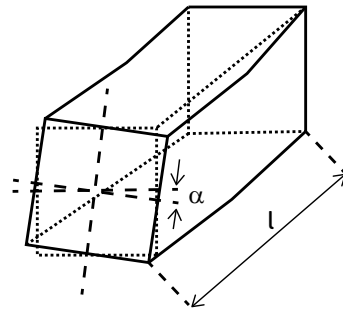

Documentation

Inspection certificates will be supplied for products being rolled in accordance with EN 10204, with the following elements being routinely analysed at cast level:

| Element | No. of reported digits after decimal point |
|--|--|
| C, Si, Mn | 2 |
| P, S, Al(t), V, Ti, Nb, Sn, Mo, Co, Ca, Cu, Ni, Cr, N ₂ | 3 |
| B | 4 |

Bespoke billets for your rolling needs

Our billets can be tailored to best meet the attributes of your products and help you meet the appropriate national and international standards. Please contact us to discuss your requirements.

| Application | Standard |
|--------------------------------------|---|
| Structural steel | Suitable for rolling to EN 10025 e.g. S235, S275, S355 |
| Structural steel | Suitable for rolling to ASTM e.g. A36, A992, A572 gr 50 |
| Plain and deformed reinforcement bar | Various |
| Low carbon wire rod | Various |



6 CONTACTS

6 CONTACTS

If you want to find out more about our product range and how we can help you, please get in touch.

The contact details listed here are correct at the time of publication. For the latest details of your nearest location, please visit britishsteel.co.uk/locations.

By product

Product areas email contacts

Semi-finished products: semisales@britishsteel.co.uk

Sections: construction@britishsteel.co.uk

Special Profiles: specialprofiles@britishsteel.co.uk

Wire Rod: wirerod@britishsteel.co.uk

Wire and processing: info@fnsteel.eu

Rail: rail@britishsteel.co.uk

By operation

Scunthorpe

Brigg Road, Scunthorpe, North Lincolnshire, DN16 1XA
T +44 (0) 1724 404040

Teesside Service Centre

Lackenby Works, Redcar, Teesside, TS6 7RP
T +44 (0) 1642 405040
E construction@britishsteel.co.uk

Skinningrove

PO Box 1, Skinningrove, Saltburn-by-the-Sea, TS13 4ET
T +44 (0) 1287 640212
E specialprofiles@britishsteel.co.uk

Ireland Service Centre – Lisburn

Steel House, Moira Road, Lisburn, BT28 2SN
T +44 (0) 2892 448208
E lisburn.sales@britishsteel.co.uk

Alblasserdam

PO Box 3, 2950 AA, Alblasserdam, The Netherlands
T +31 (0) 78 6923 100
E info@fnsteel.eu



By country

Germany

Emilienplatz 9, 58097 Hagen

T +49 (0)2331 48331-00

E germany.enquiries@britishsteel.co.uk

Italy

Via Italia 44, 20900 Monza (MB)

T +39 039 387967

E italy.enquiries@britishsteel.co.uk

Poland

Pl. Pilsudskiego 1, 00-078 Warsaw

T +48 602130191

E poland.enquiries@britishsteel.co.uk

Spain

Paseo de la Castellana 259C, Torre de Cristal, Planta 18,
Oficina 1811. 28046, Madrid

T +34 91 119 0581

E spain.enquiries@britishsteel.co.uk

Sweden

Tranbärsvägen 98, 44837 Floda

E sweden.enquiries@britishsteel.co.uk

Taiwan

Room 849, 5th Floor, No. 285, Section 4, Zhongxiao East
Road, Taipei City, 10692

T +886 (0) 266398296

E taiwan.enquiries@britishsteel.co.uk

USA

T +1 708 8190698

E usa.enquiries@britishsteel.co.uk

NOTES

NOTES

NOTES



**BRITISH
STEEL**

BRITISHSTEEL.CO.UK

A | Brigg Road, Scunthorpe, North Lincolnshire, DN16 1XA, United Kingdom
T | +44 (0)1724 404040

Care has been taken to ensure that the contents of this publication are accurate, but British Steel Limited and its subsidiaries and associated undertakings (having the meaning set out in the Companies Act 2006) do not accept responsibility or liability for errors or information that is found to be misleading.
Copyright British Steel 2023

British Steel Limited is registered in England under number 12303256 with registered office at Administration Building, Brigg Road, Scunthorpe, DN16 1XA.

BUILDING STRONGER FUTURES

PR:ENG:072023