

GATIC

DRAINAGE & ACCESS COVERS

Uniclass			
L217241			
CI/SfB			
	(99.64)	Xh	

July 2021

Engineered Access Covers & Drainage Gratings





Rain to drain solutions that set the standard for urban water management

Alumasc is a UK-based supplier of premium building products. The majority of the group's business is in the area of sustainable building products which enable customers to manage energy and water use in the built environment.

Alumasc Water Management Solutions provide 'Rain to Drain' solutions, that set the standard for urban water management. They include: **Skyline** Fascias, Soffit & Copings; **Alumasc Rainwater Gutters & Downpipes**; **Harmer** Building Drainage; **Wade** Building Drainage and **Gatic Drainage & Engineered Access Covers**.

Under the AWMS banner, customers benefit from rainwater and drainage products that capture, retain and control the flow of rainwater in the most effective way inside and outside buildings.



www.alumascwms.co.uk

Gatic - Gas and Air Tight Inspection Covers	4
Specialised Engineering. Special Advice	6
An Introduction to Gatic and our Accreditations	9
Loading Group Selector Guide	10
The Gatic Range of Access Covers	12
Product Features and Benefits	14

Gatic Loading Group F900 Covers and Frames 16-35

Introduction	16
Single covers and frames	18
Duct covers and frames	20
Continuous trench covers and frames	22
Multispan covers and frames	24
Assist Lift	28
LFA	34

Gatic Loading Group E600 Covers and Frames 36-47

Introduction	36
Single covers and frames	38
Duct covers and frames	40
Continuous trench covers and frames	42
Multispan covers and frames	44

Gatic Loading Group D400 Covers and Frames 48-69

Introduction	48
Single covers and frames	50
Duct covers and frames	52
Continuous trench covers and frames	54
Multispan covers and frames	56
Gatic PAVE	60 - 69

Gatic Loading Group C250 Covers and Frames 70-81

Introduction	70
Single covers and frames	72
Duct covers and frames	74
Continuous trench covers and frames	76
Multispan covers and frames	78

Gatic Loading Group B125 Covers and Frames 82-93

Introduction	82
Single covers and frames	84
Duct covers and frames	86
Continuous trench covers and frames	88
Multispan covers and frames	90

Additional Gatic range of Access Covers and gratings	94-100
Installation	101-106
Lifting Keys	107



Gatic's involvement with gas air-tight inspection covers spans more than 90 YEARS

In fact, one of the earliest covers produced by the company (then known as Dover Engineering) is still in service at a Shell garage in Malta, where it was first installed in 1928.

GATIC

GAS AIR TIGHT INSPECTION COVERS



A challenge in the twenties. Still challenging today.

With a history of installations dating back more than ninety years, Gatic is without doubt the fully proven International Standard for engineered access covers and drainage gratings.

Original 1928 cover still in use

When we were asked to design our first gas and air tight cover for Shell, back in the 20s, it was to a demanding specification. Our success in meeting this specification can be judged by the fact that one of the first covers supplied can still be seen in use at a Shell garage in Malta where it was originally installed.

Continuous development and refinement

Since that first success we have continued to improve and adapt our range of products to suit the ever increasing and diverse demands of travel, industry and commerce, developing ductile iron, machined access covers in a range of surface finishes and load ratings to cope with the harshest and most punishing of environments.

Future challenges

Despite this huge variety, technology never stands still for long and we are never allowed to rest on our laurels. These days more and more traffic is using our roads, carrying heavier loads at higher speeds. Huge numbers of containers pass through our ports daily and ever bigger and heavier aircraft are rolling down the taxiways and across the aprons of the airports we serve.

The challenges may be daunting but we are confident that we will continue to rise to the occasion and supply products to meet or exceed our customers demands.

Gatic standards and advice

Best products. Best advice.

Best results.

At Gatic, we know that our reputation is only as good as the performance of our products. So we do our very best to ensure that the product you buy is the right product for the job and that it is installed correctly in order to be able to do its job successfully. That is why we make a point of supplying all the help and technical support that we can.

Manufacturing standards

It all starts with the manufacturing process. All the basic components for Gatic covers are cast to exacting specifications, developed over time.

The composition of the ductile iron is tightly controlled and the tolerances of the actual casting process are held to fine and demanding limits.

This is because our products will eventually be machined to tight specifications in order to achieve the gas, air-tight and non-rocking fit upon which our reputation is built.

Gatic covers are produced in a wide range of strength ratings to suit any real-life application. When correctly installed, they can be expected to continue to perform as intended for the lifetime of the

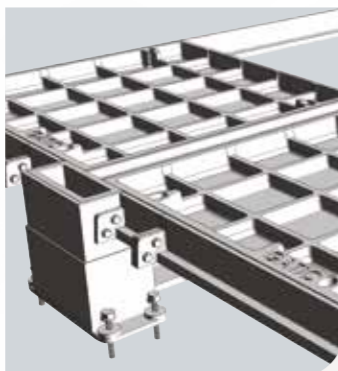

project, with minimal servicing. Our covers are designed to work effectively in the harshest environments.

Details of the range of load factors to match your requirements can be found on pages 10-11 of this publication. Selecting the appropriate product for your intended application means that you will achieve the service life and performance you need without over specifying, thus ensuring that you get the product you need with the most beneficial ratio of strength to cost. We can help you with this selection process and regard it as a very important part of our service.

Professional advice on your project

Our design engineers are available to discuss the technical aspects of any project involving Gatic covers, whether large or small. The application of a little expert knowledge often means that what appear to be intractable problems can be overcome with relative ease.

You can tap into this expertise either through our website www.gatic.com or by calling Tel: +44 (0)1787 475151.

You will find most of the information you need to narrow down the choice of covers for your particular project within the pages of this publication. To see in detail how Gatic covers are constructed and fitted on site, we suggest you go to the website, where much more information is available.

Expert advice and assistance

If your project throws up some particularly challenging problem which needs an in-depth understanding, please don't hesitate to get in touch since, in all probability, we have encountered a similar challenge before and, even if this is not the case, our 90-plus years of experience in dealing with these issues are sure to help you reach a satisfactory resolution.

Once these choices have been made you can relax, safe in the knowledge that your covers will be delivered to site in a timely manner.

Pre-delivery assembly

All Gatic products are pre-assembled and quality checked prior to dispatch from our factory.

This process not only assures us that our cover is up to specification and worthy of the Gatic name, but means that our customers can expect it to perform in service to the high standards they have a right to expect and to continue to do so long into the future.

CPDs

We also offer CPD presentations at your premises covering all aspects of surface water drainage and attenuation. Our presentations are accredited by the CPD Certification Service and count towards the continuing personal and professional development of attendees. It's a factor worth bearing in mind for those individuals seeking professional membership.

The CPD presentations currently available are Innovative Surface Water Drainage Design and Access Covers.

www.gatic.com for more information or to book your place.

NBS Plus

Our technical product information is included in this dedicated library of manufacturers' product information, contained within the UK's industry leading specification products NBS Building, NBS Landscape, NBS Engineering Services and NBS Scheduler.

Products listed in NBS Plus are directly linked to specific clauses and can be imported instantaneously into a specification. NBS Plus contains over 20,000 product specifications and is updated regularly, so designers can be confident that they are always referencing the very latest product information.

Links of all Gatic products on the NBS Plus Product Register are available on our website.

Our website now contains even more technical information and guidance than before. We have increased our online resources and improved the website design so you can now find all the technical information you need for your projects easily and quickly.

Within each product range, you can explore features and benefits, technical details, graphics, diagrams, and case studies.



Covers and frames - for performance and flexibility

Gatic sets the standard for access covers and frames, offering a combination of matchless quality with tried and tested solutions. The secret lies in the closely machined horizontal and vertical seating faces of the cover and frame components, which, when assembled into a complete unit, provide a cover and frame that is non rocking, gas & air tight.



Gatic covers are designed both to protect and give easy access to a diverse range of underground services, examples include:

- Manhole/Pump/Valve/Transformer Chambers
- Pipe and Cable Service Trenches
- Cable Draw Pits
- Lighting Pits
- Fuel and Fire Hydrant Pits
- Machinery/Plant Access Chambers
- Combined Sewer/Overflow Chambers

Typical applications can be found in a diverse range of projects including:

- Airports
- Ports/Docks
- Utilities - Gas/Electricity
- Water - Sewerage Treatment Works/ Water Treatment Works/Pumping Stations
- Power Stations/Sub-Stations
- Commercial and Industrial Applications
- Highways
- Tunnels

Cover options

Gatic covers are available in a choice of designs to suit different conditions and requirements for appearance.



Recessed for concrete infill

Covers are designed with an arrangement of cross-ribs for infilling with concrete. This provides a very strong and hard wearing surface with an attractive appearance.

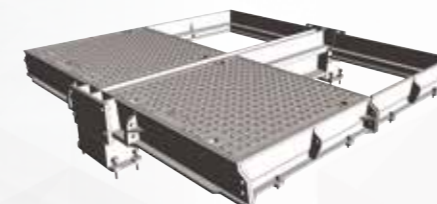

Solid top anti-slip surface

High performance covers that are lighter in weight than those incorporating concrete infill. Solid top covers incorporate a non-slip lozenge pattern on the surface.

NOTE: Covers are also available for Pavior infill.

Accreditations

Quality Assurance

The Gatic Quality Management System has been approved to BS EN ISO 9001

The Gatic Environmental Management System has been approved to ISO 14001



Our products are manufactured from 100 per cent ductile iron, giving high elasticity, which means Gatic covers and frames are highly resistant to physical forces and shock.

Gatic covers comprise ductile iron and structural steel components, all of which are recyclable.

Using this brochure

Gatic covers have been created to suit the widest range of applications and to meet different loading requirements, from relatively light loads (eg, pedestrian areas and residential roads) to the most heavy (eg, airports, dockyards, etc).

BS EN 124: classifies covers according to their place of installation as shown below. Where there is any doubt, the stronger class should be selected.

Loading description	BS EN 124	
	Class	Test Load
Areas imposing particularly high wheel loads	F900	900kN
Areas imposing high wheel loads	E600	600kN
Carriageways of roads (heavy duty)	D400	400kN
Gully tops in kerbside channels of roads	C250	250kN
Footways, pedestrian areas, etc	B125	125kN

Data from BS EN 124: (Gully tops and manhole tops for vehicular and pedestrian areas. Design requirements, type testing, marking, quality control)

The covers in our brochure are organised according to the BS EN 124 classifications. Please refer to the Loading Group Selector Guide on pages 10-11.

Loading Group Selector Guide

Loading Group F900

35 tonne slow moving wheel load - test load 900kN

Areas imposing particularly high wheel loads:

- Airfield pavements
- Taxiways
- Civil airports
- Dockyards
- Other areas where single slow moving wheel loads may be up to 35 tonne encountered



Loading Group E600

20 tonne slow moving wheel load - test load 600kN

Areas imposing high wheel loads:

- Some airfield pavements
- Dockyards Other areas where single slow moving wheel loads up to 20 tonne may be encountered

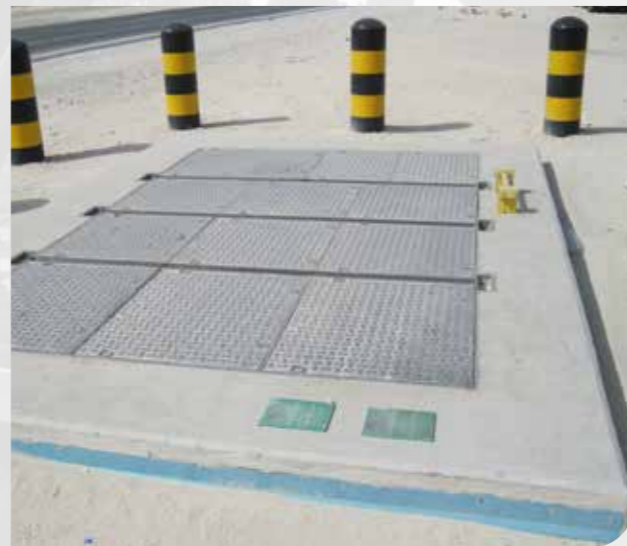

Loading Group D400

11.5 tonne wheel load - test load 400kN

- Power stations
- Carriageways
- Hard shoulders
- Parking areas for all vehicle types

For high density traffic conditions we recommend the use of a vibration resistant locking system



Loading Group C250

5 tonne wheel load - test load 250kN

Roads for relatively slow moving traffic, ie:

- Minor residential
- Cul-de-sacs
- Pedestrian precincts
- Yard



Loading Group B125

3 tonne wheel load - test load 125kN

- Footways
- Pedestrians areas
- Car parks
- Driveways
- Internal floors



The Gatic range of loading groups is organised according to BS EN 124: (Gully tops and manhole tops for vehicular and pedestrian areas. Design requirements, type testing, marking, quality control).

The Gatic Range of Access Covers

Single Covers and Frames

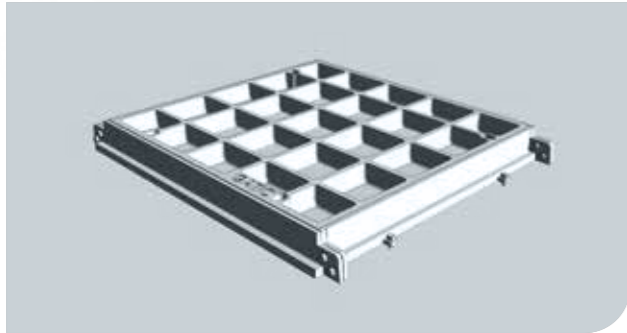

Duct Covers and Frames

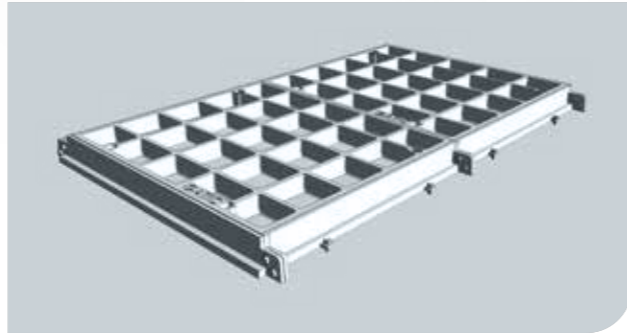

Continuous Trench Covers and Frames

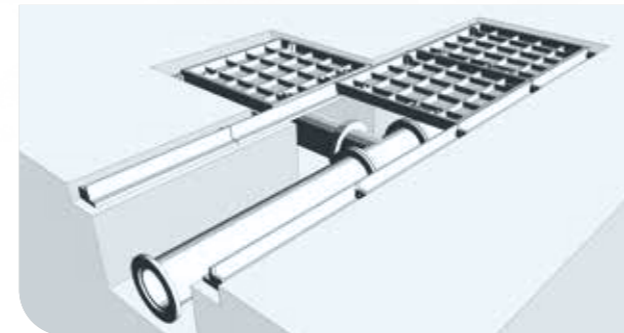

Multispan Covers and Frames

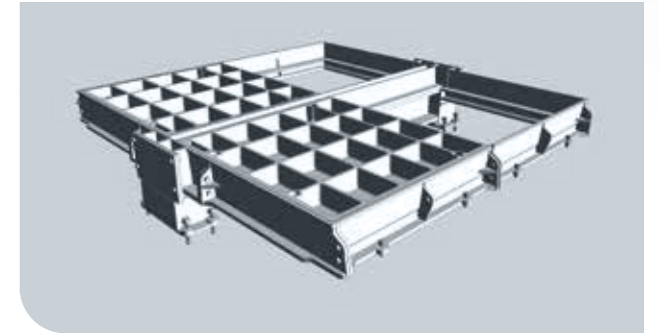

Product Features and Benefits

Cover types

Covers are recessed for concrete infill pavements or solid top according to specifier preference. Assist lift options for both recessed and solid top cover types are available.

Concrete infill recessed covers

Recessed covers are designed for filling with concrete as specified in BS EN 124 - 45 N/mm² for a test cube of 150mm, or a 40N/mm² for a test cylinder 150mm diameter x 300mm high, using a 10mm down coarse aggregate.

Anti-slip surface covers

Concrete infill covers provide a non-slip surface similar to the surrounding areas. Solid top covers incorporate a lozenge pattern on the surface.

Materials

The components of Gatic covers are manufactured from the following materials:

Ductile iron components to BS EN 1563

Structural steel sections (removable beams) to BS EN 10365.

Fine tolerances

The seating faces of Gatic covers and frames are machined to ensure metal-to-metal contact within 0.25mm tolerance.

Non-rocking

Correctly installed, Gatic covers will be non-rocking and sealed against ingress of road dirt and other detritus.

Gas, Air & Watertight

A film of graphite grease between the contact faces of Gatic units provides a gas and air & water tight seal, and a watertight joint under normal rainwater conditions.

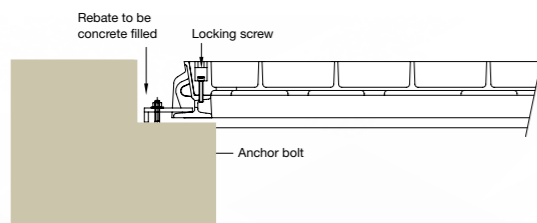

Watertightness under pressure

Pressure-tight

Standard single units with locking screws and holding-down bolts are available to withstand upward pressure. Consult our technical department for details.

Easy removal/replacement

The machined underside seating face of Gatic covers allows the sliding out of covers for easy removal or replacement.

Operator control

Jack screw operating keys locate positively and securely into Gatic covers and are a necessary tool if the inherent cover seal is to be broken effectively and to allow operator maximum control during operation.

Secure and vandal resistant

Covers are designed to prevent tampering and unauthorised removal. Gatic covers cannot be removed without the correct lifting key, so unauthorised removal is virtually impossible. Locking bolts can be fitted to Gatic cover as an additional security feature.

Ventilation

Ventilation can be provided with four 25mm diameter ventilation tubes in recessed covers.

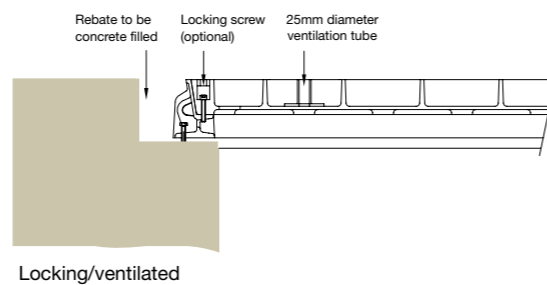

Vibration resistant

For covers in high density traffic conditions, we recommend the use of a factory-fitted vibration-resistant locking system to the recessed covers.

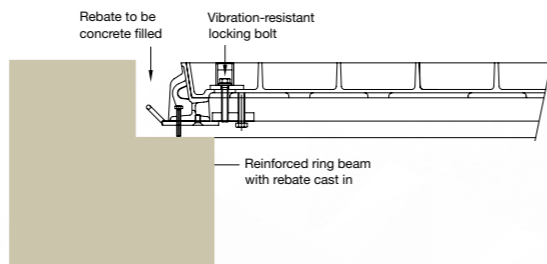

Vibration resistant

We do not recommend the use of solid top covers in high density traffic locations.

Closed keyways

Gatic cover keyways are closed and fitted with plastic plugs to prevent them from blocking up.

Loadings

All Gatic covers will withstand test load and maximum permanent set criteria specified in BS EN 124 for each loading category. Covers are load tested in their as service condition.

Rigidity

The robust and rigid design of Gatic's frames, closely toleranced covers and frames creates a rigid composite structure.

Secure support

The clear opening width between supporting frames are at least 10mm greater than the pit/chamber design to allow for minor deviations in pit construction dimensions.

Beam wallbox

Supporting beams in Gatic Multispan units are easily removed with appropriate lifting equipment for access to the total chamber area. Beam wallboxes do not project into the chamber opening.

Finishes

Units are coated with a black bituminous solution that acts as a temporary protection during transit. Removable supporting steelwork is galvanised to BS EN ISO 1461. For special applications, cover & frame components can be galvanised to BS-EN ISO 1461.

Installation

Consignments of Gatic units are accompanied by comprehensive installation instructions.

Levelling bolts

All frame bars and wallboxes are fitted with bolts to assist in the levelling of the unit during installation.

Security grids

Hinged lift-out galvanised steel security grids (with padlock facility if required) can be incorporated into Gatic units.

Environmental commitment

Responsibility towards the environment is our primary concern. Our customers often now demand products that are made from recycled and recyclable materials, supplied by companies with robust environmental policies to reduce the environmental impact of their projects for future generations.

To meet these requirements we have an integrated Quality (BS EN ISO 9001) and Environmental (BS EN ISO 14001) Management System which encompasses the design, manufacture and management systems within the company and ensures our commitment to continuous environmental improvements regarding the manufacture and design of all our products in the following ways:

- Minimise environmental impact
- Commit organisational resources to energy management
- Reduce energy costs
- Give high priority to energy efficient investments
- Consider life cycle energy costs for all new projects
- Minimise CO₂ emissions year on year
- Use energy from sustainable resources wherever possible

To achieve these goals we have put in place the necessary systems and controls to meet demanding environmental targets and to make sure that these are maintained for the future benefit of the environment and our customers alike.

Gatic services

Gatic offers a full support service to specifiers and contractors, including Computer Aided Design. AutoCAD compatible details of all Gatic products are available. Please consult our technical department for assistance.

In view of our commitment to product improvement, we reserve the right to alter designs without notice. Design changes will not adversely affect the performance or loading capability of our products.



Loading Group F900

AREAS OF EXCEPTIONALLY HIGH WHEEL LOADS, AIRCRAFT HARD-STANDINGS, TAXIWAYS AT CIVIL AIRPORTS
CONTAINER PORTS AND DOCKYARDS

Introduction

This section includes Gatic covers and frames designed for Loading Group F900.

35 tonne slow moving wheel load, test load 900kN - Suitable for:

- Aircraft hard-standings and taxiways at civil airports
- Container ports and dockyards where individual wheel loadings of up to 35 tonnes may be encountered
- F900 assemblies are available with a choice of cover designs - recessed or solid top.



Solid top

Solid top cover types are lighter in weight than recessed covers, and feature an anti-slip surface. Solid top covers are denoted by the code Type RSF depicted in section on the following pages.

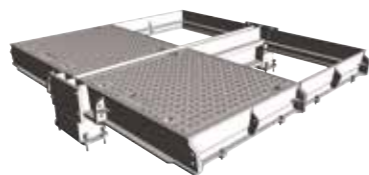

Recessed for concrete infill

Recessed covers are available in a choice of designs designated by a 'Type' reference. F900 recessed covers are available as Type DLF, DM, RRF, DM/F, DMR. Section drawings of the different recessed cover types are shown on the following pages.

To prevent movement of covers in high traffic conditions, we recommend the use of a factory fitted vibration-resistant locking system. Can be fitted to recessed covers only. See page 14.



F900

Product Ranges

Single covers and frames



Duct covers and frames



Assist Lift



Continuous trench covers and frames



Multispan covers and frames



LFA



Loading Group F900

AREAS OF EXCEPTIONALLY HIGH WHEEL LOADS, AIRCRAFT HARD-STANDINGS, TAXIWAYS AT CIVIL AIRPORTS
CONTAINER PORTS AND DOCKYARDS



- Covers recessed for concrete infill
 - Cover type: DLF, DMR, DM, DM/F, RRF
- To specify state:
- Loading group
 - Pit clear opening size length (L) x span (S)
 - Cover type

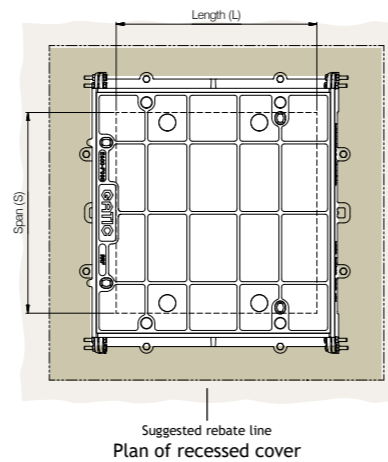

Pit clear opening sizes L x S	Cover type	Overall frame size length x width x depth	Suggested rebate size length x width x depth
750 x 300	DLF	900 x 540 x 75	1050 x 600 x 100
600 x 450	DMR	750 x 670 x 140	1000 x 850 x 165
750 x 450	DMR	900 x 670 x 140	1150 x 850 x 165
600 x 600	RRF	750 x 840 x 100	1000 x 1000 x 125
750 x 600	RRF	900 x 840 x 100	1150 x 1000 x 125
900 x 600	RRF	1050 x 840 x 100	1300 x 1000 x 125
750 x 750	RRF	900 x 990 x 100	1150 x 1150 x 125
900 x 750	RRF	1050 x 990 x 100	1300 x 1150 x 125
900 x 900	RRF	1120 x 1140 x 100	1300 x 1300 x 125
600 x 1050	DM	820 x 1270 x 140	1000 x 1450 x 165
750 x 1050	DM	970 x 1270 x 140	1150 x 1450 x 165
1000 x 1050	DM	1220 x 1270 x 140	1400 x 1450 x 165
600 x 1200	DM	820 x 1420 x 140	1000 x 1600 x 165
750 x 1200	DM	970 x 1420 x 140	1150 x 1600 x 165
600 x 1500	DM/F	820 x 1720 x 140	1000 x 1900 x 165
750 x 1500	DM/F	970 x 1720 x 140	1150 x 1900 x 165



- Covers with solid top
 - Cover type RSF
- To specify state:
- Loading group
 - Pit clear opening size length (L) x span (S)
 - Cover type



Pit clear opening sizes L x S	Cover type	Overall frame size length x width x depth	Suggested rebate size length x width x depth
600 x 600	RSF	750 x 840 x 100	1000 x 1000 x 125
750 x 600	RSF	900 x 840 x 100	1150 x 1000 x 125
900 x 600	RSF	1050 x 840 x 100	1300 x 1000 x 125
700 x 700	RSF	850 x 940 x 100	1100 x 1100 x 125
750 x 750	RSF	900 x 990 x 100	1150 x 1150 x 125
900 x 750	RSF	1050 x 990 x 100	1300 x 1150 x 125
900 x 900	RSF	1120 x 1140 x 100	1300 x 1300 x 125
1000 x 1000	RSF	1220 x 1240 x 100	1400 x 1400 x 125

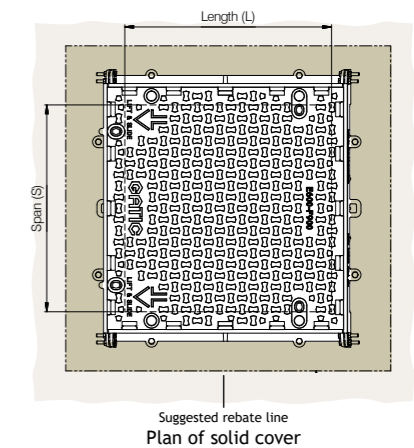

For high density traffic conditions refer to page 14.

Cover types

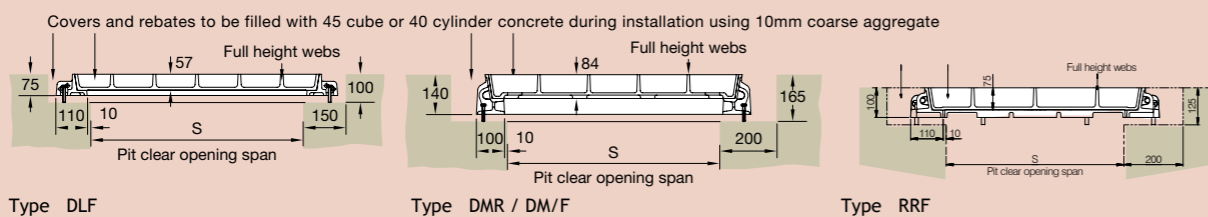

Cover types

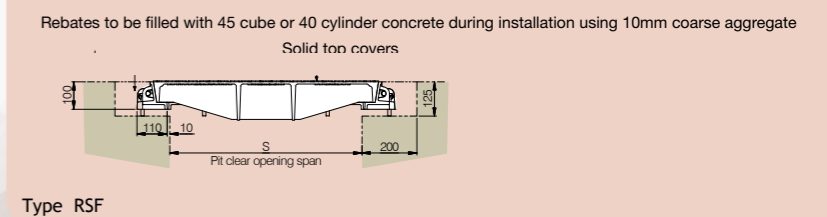

Loading Group F900

AREAS OF EXCEPTIONALLY HIGH WHEEL LOADS, AIRCRAFT HARD-STANDINGS, TAXIWAYS AT CIVIL AIRPORTS
CONTAINER PORTS AND DOCKYARDS



- Covers recessed for concrete infill
- Cover type DLF, DMR, DM, DM/F, RRF

To specify state:

- Loading group
- Pit clear opening size length (L) x span (S)
- Cover type

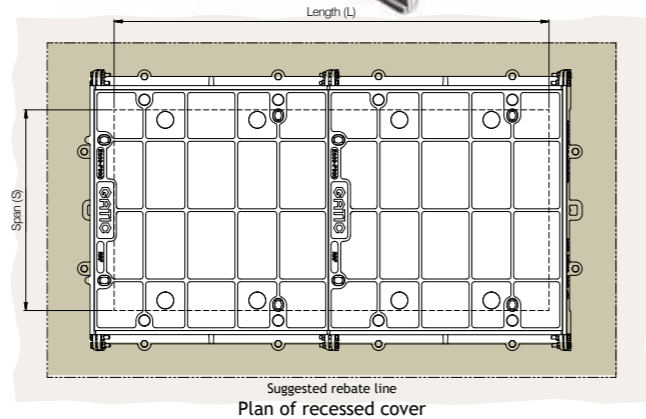

Pit clear opening sizes	Cover type	Suggested rebate size length x width x depth
300	DLF	(L + 300) x 600 x 100
450	DMR	(L + 400) x 850 x 165
600	RRF	(L + 400) x 1000 x 125
750	RRF	(L + 400) x 1150 x 125
900	RRF	(L + 400) x 1300 x 125
1050	DM/F	(L + 400) x 1450 x 165
1200	DM/F	(L + 400) x 1600 x 165
1500	DM/F	(L + 400) x 1900 x 165

Pit clear opening span (S)	Cover type	Standard pit clear opening length (L)											
		1300	1450	1600	1750	1900	2000	2150	2300	2450	2600	2700	2750
300	DLF	*	*	2	*	*	*	*	*	3	*	*	*
450	DMR	2	2	2	*	*	3	3	3	3	*	4	*
600	RRF	2	2	2	2	2	3	3	3	3	3	4	3
750	RRF	2	2	2	2	2	3	3	3	3	3	4	3
900	RRF	2	2	2	2	2	3	3	3	3	3	4	3
1050	DM/F	2	2	2	*	*	3	3	3	3	*	4	*
1200	DM/F	2	2	2	*	*	3	3	3	3	*	4	*
1500	DM/F	2	2	2	*	*	3	3	3	3	*	4	*

Pit clear opening span (S)	Cover type	Standard pit clear opening length (L)											
		2850	2900	3000	3150	3300	3400	3550	3700	3850	3900	4000	4150
300	DLF	*	*	*	*	4	*	*	*	*	*	*	5
450	DMR	4	*	4	4	4	5	5	5	5	*	5	5
600	RRF	4	3	4	4	4	5	5	5	5	4	5	5
750	RRF	4	3	4	4	4	5	5	5	5	4	5	5
900	RRF	4	3	4	4	4	5	5	5	5	4	5	5
1050	DM/F	4	*	4	4	4	5	5	5	5	*	5	5
1200	DM/F	4	*	4	4	4	5	5	5	5	*	5	5
1500	DM/F	4	*	4	4	4	5	5	5	5	*	5	5

Cover types

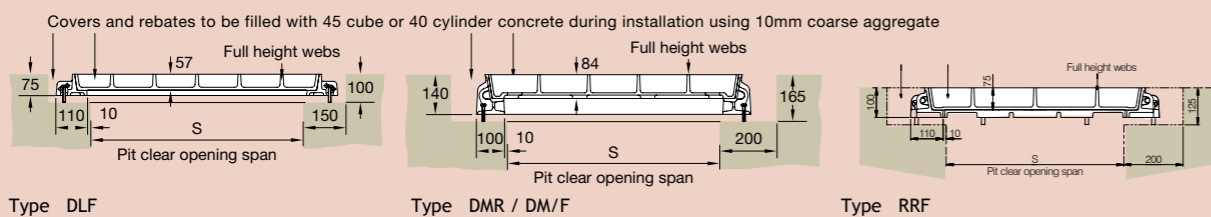

* Indicates standard sizes not available The number shown indicates the quantity of cover parts Other standard sizes may be available, refer to our technical department



- Covers with solid top
- Cover type RSF

To specify state:

- Loading group
- Pit clear opening size length (L) x span (S)
- Cover type

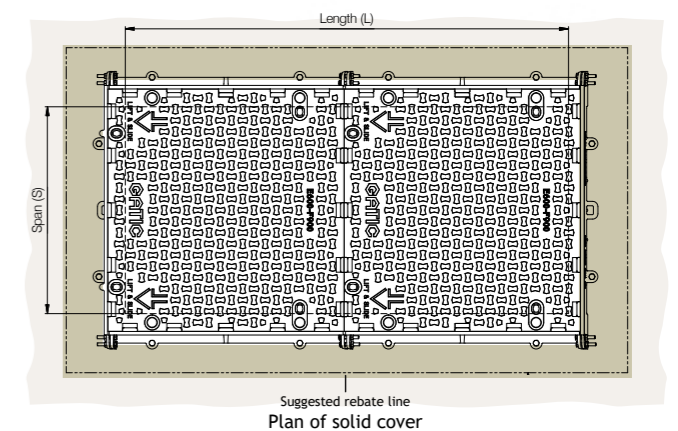

Pit clear opening sizes	Cover type	Suggested rebate size length x width x depth
600	RSF	(L + 400) x 1000 x 125
700	RSF	(L + 400) x 1100 x 125
750	RSF	(L + 400) x 1150 x 125
900	RSF	(L + 400) x 1300 x 125

For high density traffic conditions refer to page 14.

Pit clear opening span (S)	Cover type	Standard pit clear opening length (L)												
		1300	1450	1500	1600	1750	1900	2000	2150	2300	2450	2600	2700	2750
600	RSF	2	2	*	2	2	2	3	3	3	3	3	4	3
700	RSF	*	*	2	*	*	*	*	*	3	*	*	*	*
750	RSF	2	2	*	2	2	2	3	3	3	3	3	4	3
900	RSF	2	2	*	2	2	2	3	3	3	3	3	4	3

Pit clear opening span (S)	Cover type	Standard pit clear opening length (L)												
		2850	2900	3000	3100	3150	3300	3400	3550	3700	3850	3900	4000	4150
600	RSF	4	3	4	*	4	4	5	5	5	5	4	5	5
700	RSF	*	*	*	4	*	*	*	*	*	*	5	*	*
750	RSF	4	3	4	*	4	4	5	5	5	5	4	5	5
900	RSF	4	3	4	*	4	4	5	5	5	5	4	5	5

* Indicates standard sizes not available The number shown indicates the quantity of cover parts Other standard sizes may be available, refer to our technical department

Cover types

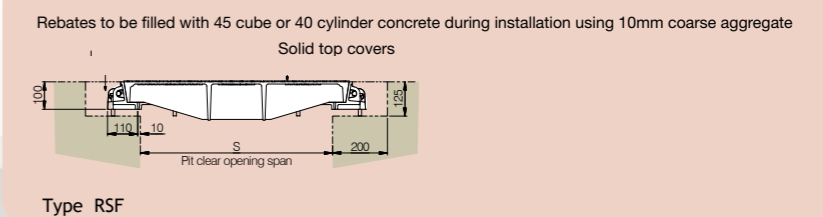

Loading Group F900 AREAS OF EXCEPTIONALLY HIGH WHEEL LOADS, AIRCRAFT HARD-STANDINGS, TAXIWAYS AT CIVIL AIRPORTS CONTAINER PORTS AND DOCKYARDS

F900

Continuous recessed trench covers and frames



- Covers recessed for concrete infill
- Cover types: DLF, DMR, DM, DM/F, RRF

To specify state:

1. Loading group
2. Cover type
3. Supply layout drawing of trenches

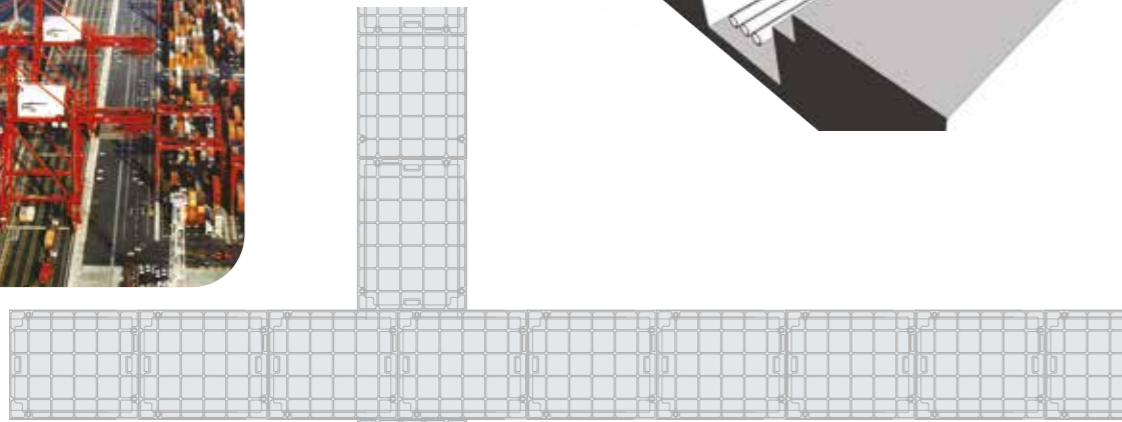
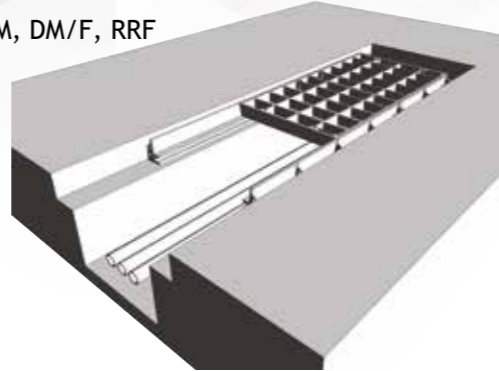

Continuous recessed cover

Pit clear opening span	Cover type
300	DLF
450	DMR
600	RRF
750	RRF
900	RRF
1050	DM/F
1200	DM/F
1500	DM/F

For Type DM/F 1050,1200,1350 and 1500 spans refer to our technical department



Gatic covers can be formed to make continuous trenches or layouts providing total access to services below.

Construction drawings are required so that Gatic cover layout drawings can be prepared.



Cover types

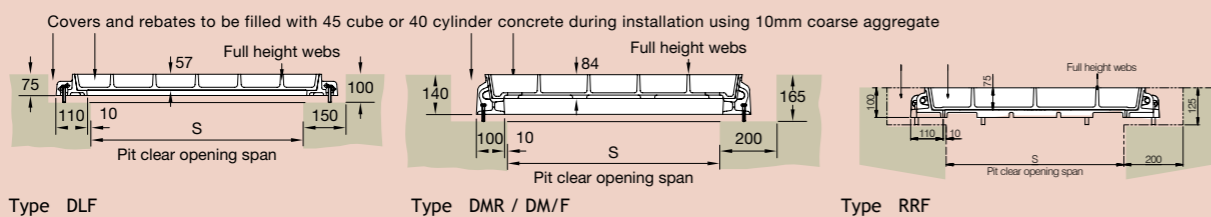

F900

Continuous solid top trench covers and frames



- Covers with solid top
- Cover types: RSF

To specify state:

1. Loading group
2. Cover type
3. Supply layout drawing of trenches

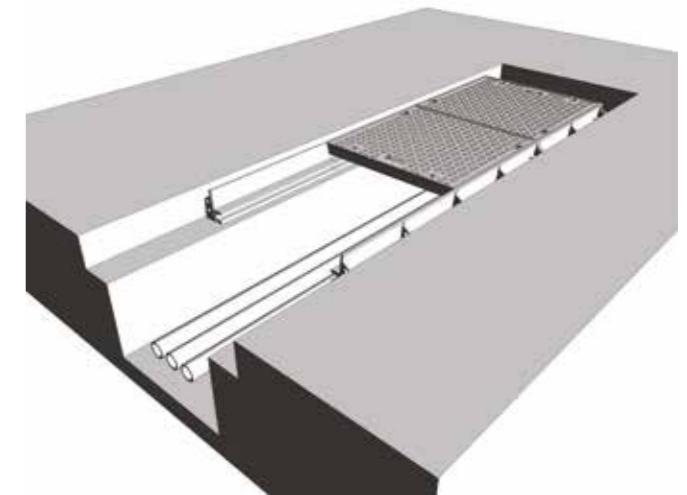

Continuous solid top cover

Pit clear opening span	Cover type
600	RSF
700	RSF
750	RSF
900	RSF

Note: Solid top covers can only be supplied in continuous straight runs

Standard Solid top covers are supplied in straight runs. Junctions and splays can be achieved by the inclusion of localised recessed covers. Refer to our technical department for more information.

For high density traffic conditions refer to page 14.



Cover types

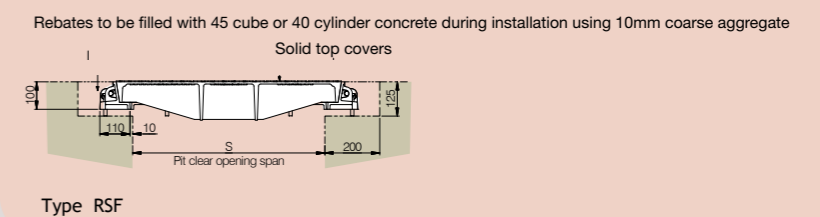

Loading Group F900

AREAS OF EXCEPTIONALLY HIGH WHEEL LOADS, AIRCRAFT HARD-STANDINGS, TAXIWAYS AT CIVIL AIRPORTS
CONTAINER PORTS AND DOCKYARDS W

Specification

Below is a sample specification information and notes for Multispan recessed covers and frames.

For more details on features and benefits of Gatic covers.

Loading group Gatic F900

35 tonne wheel load - test load 900 kN.

Materials

Ductile iron components to BS EN 1563.

Structural steel removable beams to BS EN 10365.

Finishes

Units coated with black bituminous solution for protection during transit. Galvanised alternative available.

Removable supporting steelwork galvanised to BS EN ISO 1461.

Infill and surround concrete by customer

Concrete strength, using 10mm coarse aggregate, to be:

45N/mm² for a test cube of 150mm or

40N/mm² for a test cylinder of 150mm diameter x 300mm high.

Installation

In accordance with instructions supplied by Gatic.

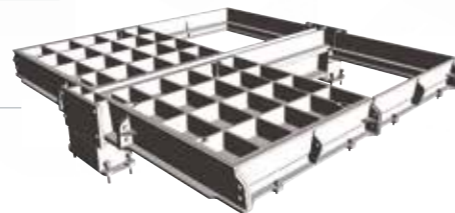

Type RRF recessed



Type RSF solid top

To specify use size and description format as follows:

Gatic Multispan Recessed covers and frames

Cover type **RRF recessed**

Multiple access covers recessed for concrete infill with removable beams.

.... in no. (length) x (span) mm pit clear opening multi span cover and frame.

Gatic Type RRF Ductile Iron Recessed Cover in parts complete with

.... in no. x mm galvanised removable support beam spanning the (length) mm way.

Suitable for Loading Group F900 - 35 Tonnes Wheel Load (pneumatic tyre).

Gatic Multispan Solid Top covers and frames

Cover type **RSF solid top**

Multiple solid top access covers with removable beams.

.... in no. (length) x (span) mm pit clear opening multi span cover and frame.

Gatic Type RSF Ductile Iron Solid Top Cover in parts complete with

.... in no. x mm galvanised removable support beam spanning the (length) mm way.

Suitable for Loading Group F900 - 35 Tonnes Wheel Load (pneumatic tyre).

Standard pit clear opening sizes are shown on p25

Beam sizes and other dimensions are shown on p26 - p27

For high density traffic conditions, refer to page 14.

Product Selection

Refer to the table to identify which cover and beam configuration you require against pit clear opening length (L) and pit clear opening span (S). All dimensions are in millimetres.

Note: All dimensions shown in red are made up using 700 x 700 solid top covers. Not compatible with other lengths

		Pit clear opening length (L) mm									Beam centres mm																			
		2 parts			3 parts			4 parts			A	B	C	D	E															
Pit clear opening span (S) mm	2 parts 1 beam	1380	1450	1500	1600	1750	1900	2000	2150	2300	2450	2600	2750	2900	2700	2850	3000	3100	3150	3300	3450	3600	3750	3900						
		1530	1580	1680	1830	1980																			690	690				
																									840	690				
	3 parts 2 beams	2160	2310	2460	2610	2760	2910	3060																	690	780	690			
																									690	930	690			
																									840	780	840			
	4 parts 3 beams	2940	3090	3240	3390	3540	3690	3840	3990	4140																690	780	780	690	
																										840	780	780	690	
																										840	780	780	840	
	5 parts 4 beams	3720	3870	4020	4170	4320	4470	4620	4770	4920	5070	5220														690	780	780	780	690
																										690	780	930	780	690
																											840	780	780	780

Note: For other pit clear opening sizes please refer to our technical department

Loading Group F900

AREAS OF EXCEPTIONALLY HIGH WHEEL LOADS, AIRCRAFT HARD-STANDINGS, TAXIWAYS AT CIVIL AIRPORTS
CONTAINER PORTS AND DOCKYARDS

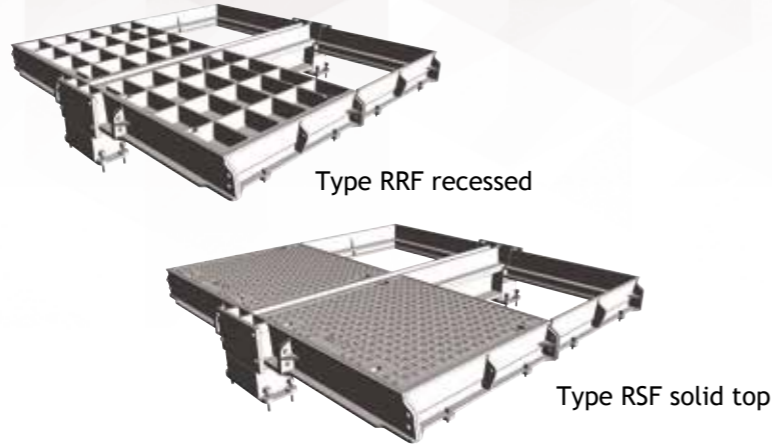

- Covers recessed for concrete infill or solid top
- Cover types: RRF (recessed)
RSF (solid top)

The details below show plan and sections of a typical recessed/solid top unit.

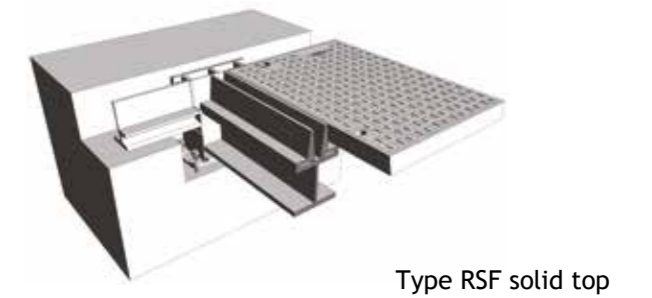
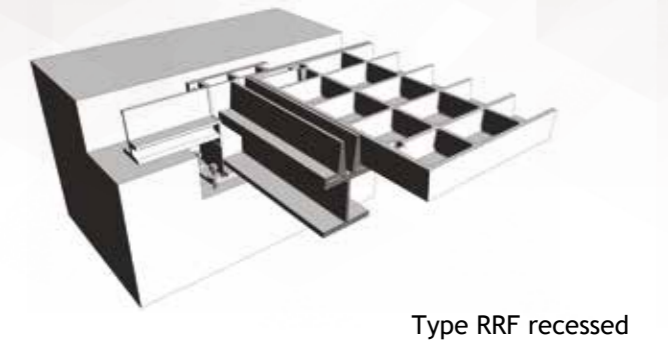
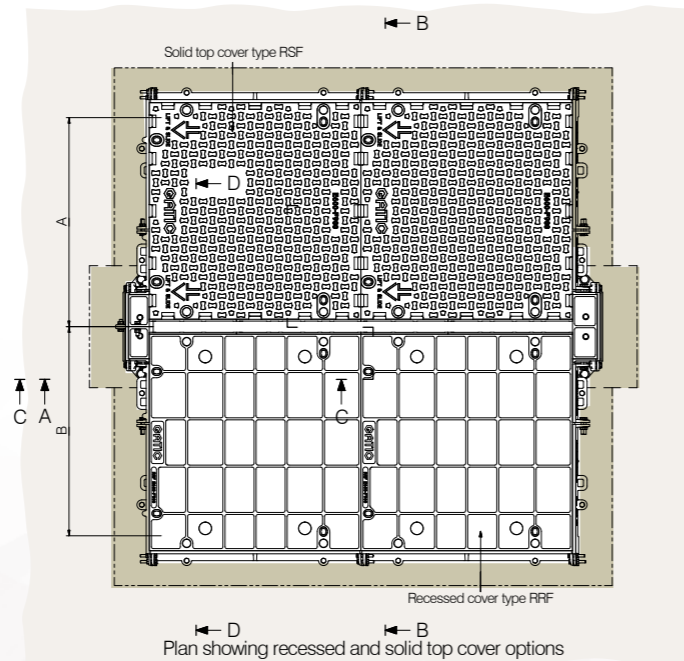
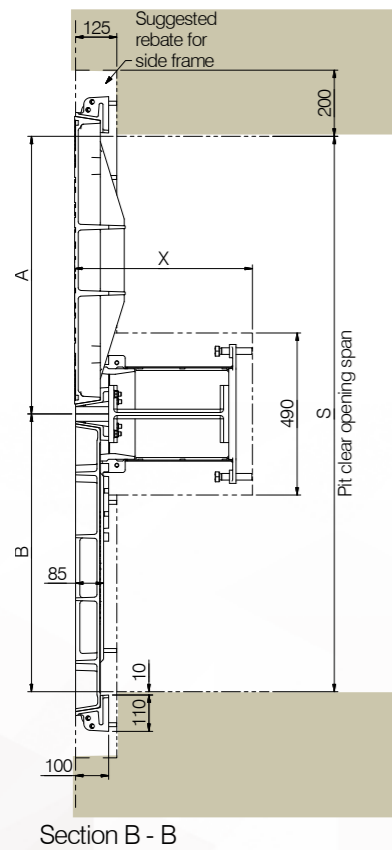
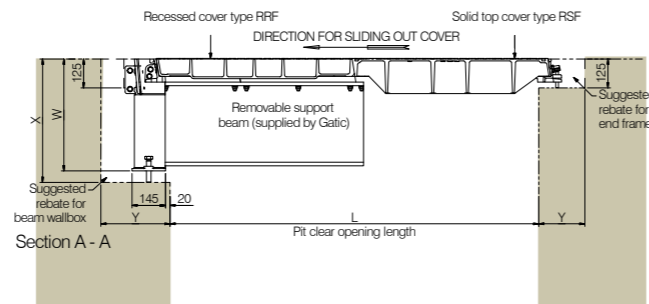

Beam Size

The required beam size for Multispan covers is dependent on the pit clear opening length and the loading group.

The table shows maximum beam length against beam size. The removable support beams are supplied by Gatic.

The table also indicates dimensions of the beam wallbox and rebate to suit different beam sizes. See also the accompanying section details.

Support beam size chart

Removable support beam size	Max pit clear opening length (L)	Beam wallbox dimensions			
		V	W	X	Y
356 x 171 x 67 kg/m U.B	1750	465	487	535	300
457 x 152 x 82 kg/m U.B	2600	568	590	635	300
533 x 210 x 122 kg/m U.B	3600	647	669	715	300
610 x 229 x 140 kg/m U.B	3900	719	741	790	350

Note: Removable support beams are supplied by Gatic. For clear opening lengths longer than 3900 please refer to our technical department.

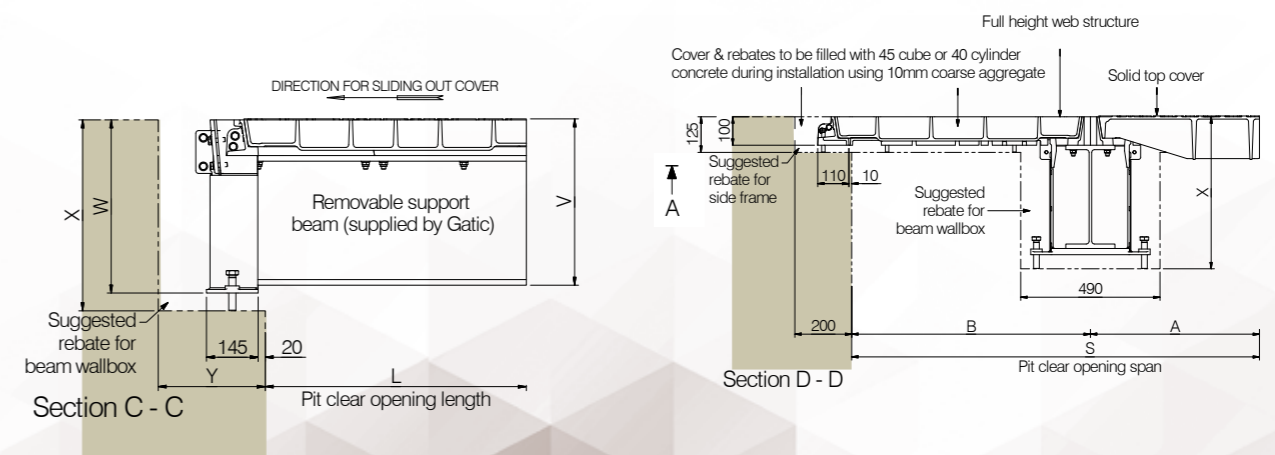

Loading Group F900 - Assist Lift

F900
Assist Lift

Gatic has been setting the industry standard for access covers since 1928. Over this time we have developed products to suit many different industries. The Assist lift covers featured in this brochure have been refined over many years and are in service around the world.

Assist lift covers facilitate one person opening of a F900 load rated ductile iron cover either as an individual cover or as part of a multi cover arrangement. The modular nature of the Gatic system of removable covers is designed to provide sealed, uninterrupted access to the services below whether as a single cover, duct or multispan arrangement with removable support beams.

A removable system for virtually any size of pit configuration and loading can be developed. Gatic covers are designed to protect and give access to a diverse range of underground services. Examples include, manhole/pump/valve/transformer chambers, pipe and cable service trenches, cable draw pits, lighting, fuel and fire hydrant pits, machinery/plant access chambers, tunnel shaft access chambers, combined sewer/overflow chambers and storm tie down pits.

Gatic specialise in the design of covers for airports, container ports, dockyards and industrial areas where extreme wheel loadings from aircraft, container carrying equipment and other vehicles may be encountered. Covers are available with recessed tops for concrete infill at site or with solid cast iron tops. Assist lift covers can be incorporated into larger covers for other loading categories upon request.



Cover types

Covers are available either recessed for concrete infill at site or with solid ductile iron tops.

Concrete infill recessed covers

Recessed covers are designed for infilling at site. Concrete should be as specified in BS EN 124 - 45/mm² for a test cube 150mm or 40N/mm² for a test cylinder 150mm dia x 300mm high, using 10mm coarse aggregate.

Anti-slip surface

Concrete infill covers provide a non-slip surface similar to the surrounding areas, solid top covers incorporate a raised lozenge pattern on the surface.

Materials

The components of Gatic covers are manufactured from the following materials: Ductile iron to BS EN 1563 Structural steel sections (removable support beams) to BS4-1. M-Struts® and hinges in stainless steel grade 304.

Fine tolerances

The seating faces of Gatic covers and frames are machined finished and assembled in metal to metal contact within a tolerance of 0.25mm.

Non-rocking

Correctly installed, Gatic covers will be non-rocking under traffic and sealed against road dirt and other detritus.

Gas, Air & Watertight

A film of graphite grease between the machined contact faces of Gatic covers and frames provides a gas and airtight seal and a watertight joint under normal rainwater conditions.

Removal/Replacement slide-out covers

The machined seating faces facilitate the sliding out of covers for removal and replacement. Lifting keys are available on request for use with cranes and other mechanical devices.

Secure and vandal resistant

Covers are designed to prevent tampering and unauthorised removal without the use of the specially designed Gatic lifting keys. Locking bolts can be fitted to Gatic cover keyways as an additional security feature. Gatic Type SSA covers incorporate a slam latch mechanism complete with a retained locking bolt. Gatic Types RGA and SGA incorporate two locking bolts as standard.

Closed keyways

Gatic cover keyways are closed and supplied with plastic plugs to prevent them from blocking with detritus.

Safe Lifting - Assist lift covers

Gatic Assist lift covers have been designed to be lifted and closed by a single operator. The maximum lifting and closing force will be approximately 25kg depending on the size, type and lifting characteristic that has been chosen.

M-Struts®

M-Struts® are designed for demanding environments and provide a maintenance free alternative to conventional gas struts. M-Struts® are made of grade 304 stainless steel. Unlike gas and pneumatic models, M-Struts® have no internal gases to leak or seals to fail in extreme conditions.

Hinges

Gatic Assist lift covers are supplied with flush-fitting hinges as standard but can be supplied with barrel hinges upon request.

Loadings

All Gatic covers within this brochure will withstand the test load, deflection and maximum deformation criteria specified in BS EN 124 for load category F900. Recessed cover are tested in their in-service conditions

Please note:

Gatic do not recommend the use of assist lift covers in high density traffic conditions.

Beam wallbox

Supporting beams in Gatic multispan units can be easily removed with the appropriate lifting equipment to give uninterrupted access to the total chamber area. The beam wallboxes do not project into the chamber opening.

Finishes

Covers and frames are coated with black bituminous solution which forms a temporary protection during transit. Removable support beams are galvanised to BS EN ISO 1461. When installed in extreme environments, the covers and frames can also be galvanised, when specified.

Levelling bolts

All side frame bars and wallboxes are fitted with bolts to assist in the levelling of the unit during installation.

Also available for C250 & D400 Loading.

F900
Assist Lift

Loading Group F900

AREAS OF EXCEPTIONALLY HIGH WHEEL LOADS, AIRCRAFT HARD-STANDINGS, TAXIWAYS AT CIVIL AIRPORTS
CONTAINER PORTS AND DOCKYARDS

Gatic Type SSA side hinged covers are all assist lift to give complete access to the chamber below.

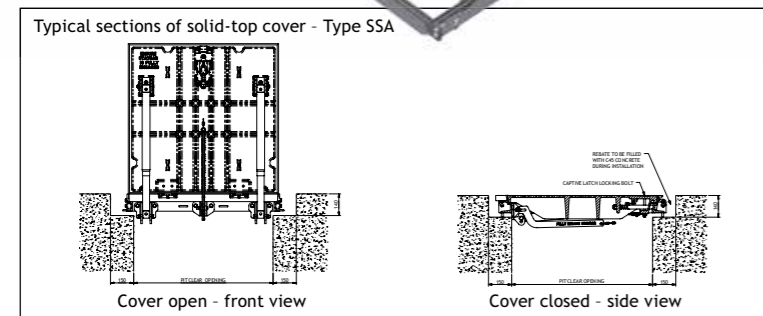
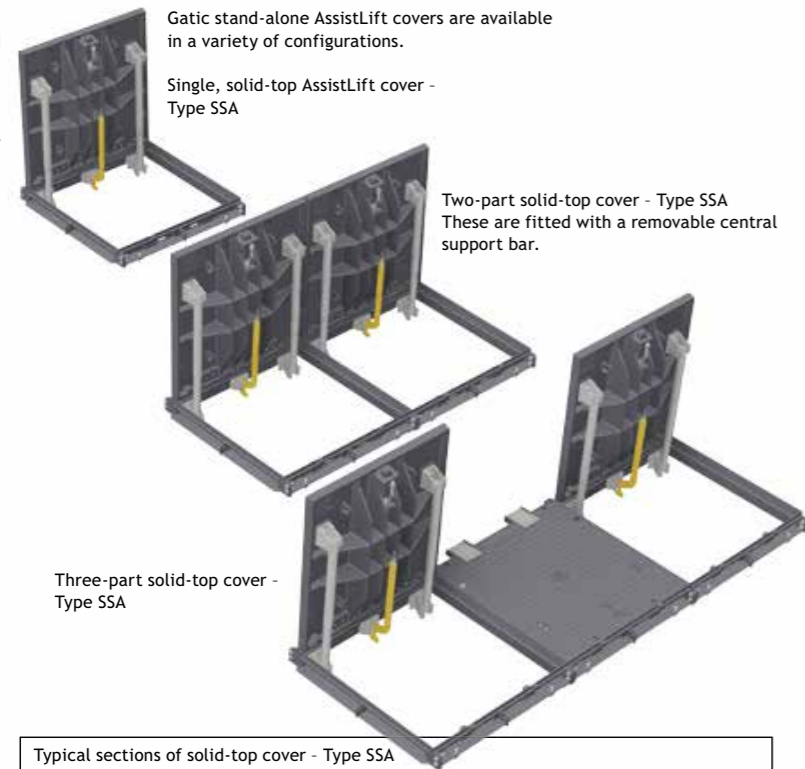

Gatic with side hinged AssistLift covers
These can be supplied in standard units as per the sizes shown on the chart below.

Longer lengths are available Number of cover parts are shown in the boxes under the standard pit clear opening length (L)

"Pit clear opening span (S)"	"Solid Top Cover type"	Standard pit clear opening length (L)							
		750	1580	2410	3240	4070	4900	5730	
760	SSA	1	2	3	4	5	6	7	

"Pit clear opening span (S)"	"Solid Top Cover type"	Standard pit clear opening length (L)							
		900	1880	2860	3840	4820	5800	6780	
910	SSA	1	2	3	4	5	6	7	

Support frame between covers is removable to give uninterrupted access to the chamber below



Gatic Type SFA Solid Top end hinged covers give complete access to the chamber opening when used as a single cover. When integrated as part of a duct or multispan arrangement, they provide either one person access to a chamber above a ladder or access to equipment that would need to be inspected/operated on a regular basis. Covers are available for 900 span only.

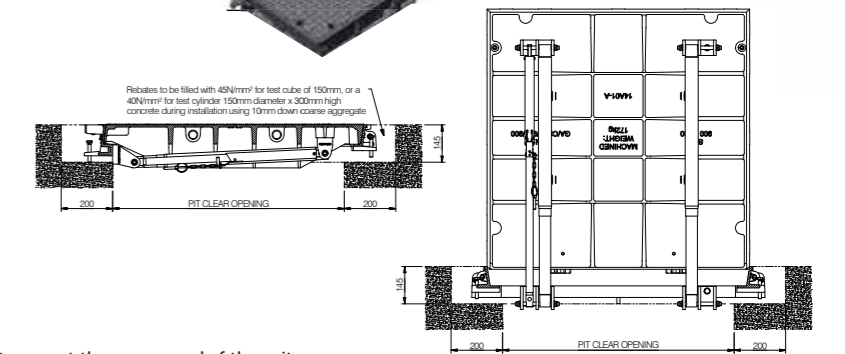
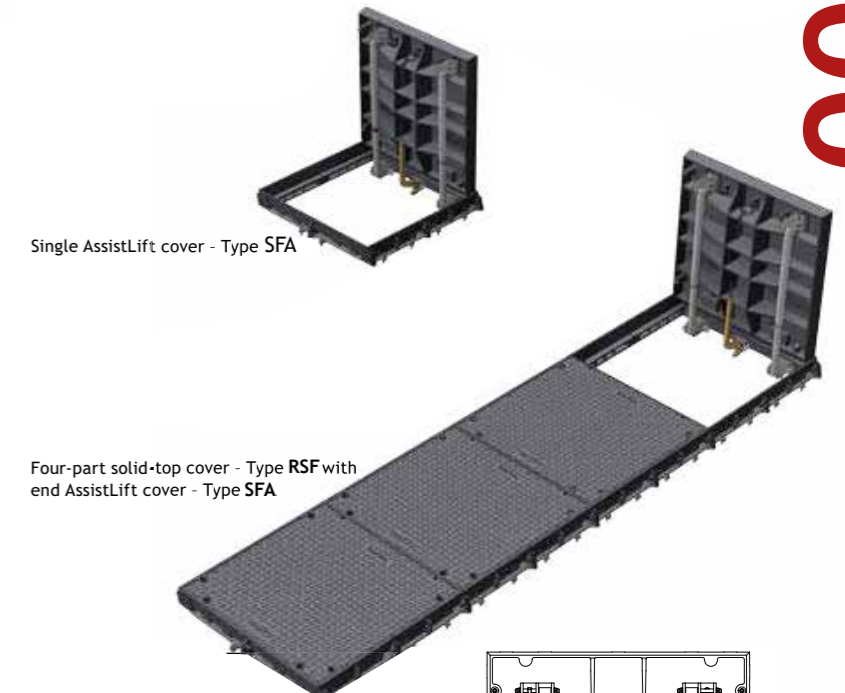

Gatic recessed or solid top covers and frames with one AssistLift cover at the reverse end of the unit.
These can be supplied in standard units as per the sizes shown on the chart below.

Longer lengths are available Number of cover parts are shown in the boxes under the standard pit clear opening length (L)

Pit clear opening span (S)	Cover type	Standard pit clear opening length (L)																	
		750	900	1450	1600	1750	1900	2150	2300	2450	2600	2750	2850	2900	3000	3150	3300	3450	3550
750	SFA	1	*	2	2	2	*	3	3	3	3	3	4	*	4	4	4	4	5
900	SFA	*	1	*	2	2	2	*	3	3	3	3	*	3	4	4	4	4	*

Pit clear opening span (S)	Cover type	Standard pit clear opening length (L)																	
		3600	3700	3750	3850	3900	4000	4150	4250	4300	4400	4450	4550	4600	4700	4750	4850	4900	
750	SFA	4	5	4	5	*	5	5	6	5	6	5	6	5	6	5	6	*	
900	SFA	4	5	4	5	4	5	5	*	5	6	5	6	5	6	5	6	5	

Loading Group F900

AREAS OF EXCEPTIONALLY HIGH WHEEL LOADS, AIRCRAFT HARD-STANDINGS, TAXIWAYS AT CIVIL AIRPORTS
CONTAINER PORTS AND DOCKYARDS

Gatic multispans access covers incorporate removable support beams so that much larger pit openings can be covered. The table shows standard multispans units that can have an AssistLift cover installed at the back end of the unit. In some cases, more than one AssistLift cover can be fitted.

These heavy duty covers are specifically designed for airports, container ports and docks where abnormal wheel loadings from heavy vehicles are envisaged.

Assist Lift covers can also be fitted to the front end of a unit providing it is in a different span to an Assist Lift cover at the back end.



For further assistance specifying your Assist Lift requirement within a multispans arrangement, please contact our technical team

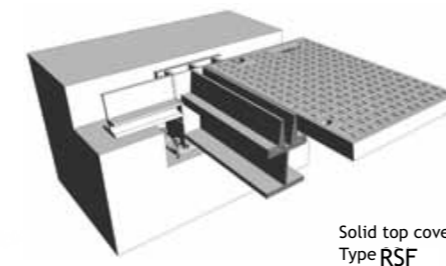
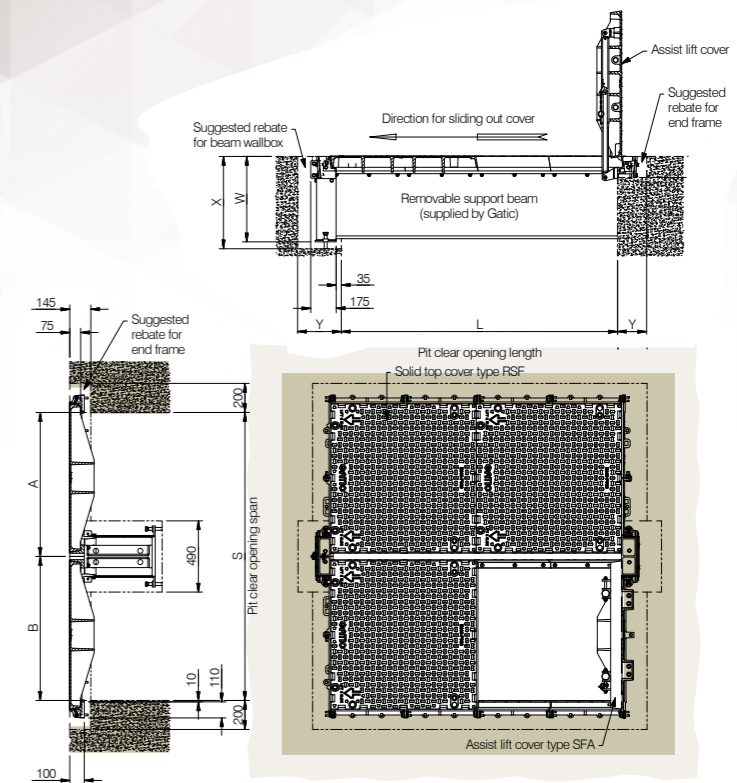

Solid top cover - Type RSF

Beam size

The required beam size for multispans covers is dependant upon the pit clear opening length and the loading group.

The table shows the minimum beam length against beam size. The removable support beams are supplied by Gatic.

The table also shows dimensions of the beam wallbox and rebate to suit different beam sizes. See also accompanying section details.

Removable support beam size	Max pit clear opening length (L)	Beam wallbox dimensions			
		V	W	X	Y
356 x 171 x 67kg/m UB	1750	467	490	535	300
457 x 152 x 82kg/m UB	2600	568	595	635	300
533 x 210 x 122kg/m UB	3600	648	670	715	300
610 x 229 x 140kg/m UB	3900	720	745	790	300

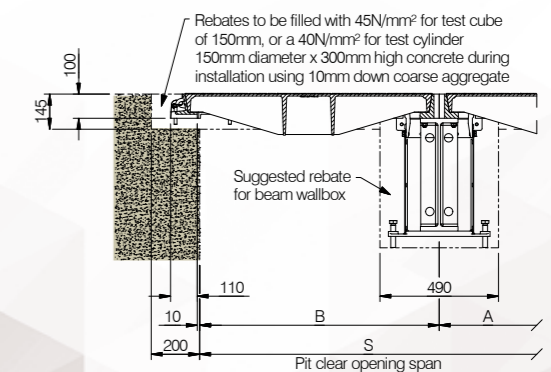
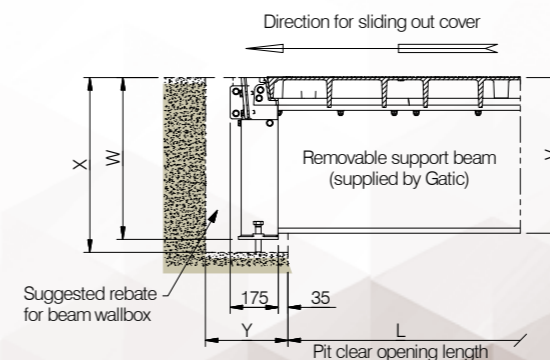

Assist Lift Multispans covers & Frames

F900 Assist Lift Multispans covers & Frames

Pit clear opening span (S) mm	Pit clear opening length (L) mm																Possible number of Assist Lift Covers		
	2 Parts				3 Parts				4 Parts								750	900 Only	Max
	1450	1600	1750	1900	2150	2300	2450	2600	2750	2900	2850	3000	3150	3300	3450	3600			
1530	[Diagram: 2x2 grid]				[Diagram: 3x2 grid]				[Diagram: 4x2 grid]								1	*	1
1680	[Diagram: 2x2 grid]				[Diagram: 3x2 grid]				[Diagram: 4x2 grid]								2	1	2
1830	[Diagram: 2x2 grid]				[Diagram: 3x2 grid]				[Diagram: 4x2 grid]								1	1	2
1980	[Diagram: 2x2 grid]				[Diagram: 3x2 grid]				[Diagram: 4x2 grid]								*	2	2
2310	[Diagram: 2x3 grid]				[Diagram: 3x3 grid]				[Diagram: 4x3 grid]								1	*	1
2460	[Diagram: 2x3 grid]				[Diagram: 3x3 grid]				[Diagram: 4x3 grid]								2	1	2
2610	[Diagram: 2x3 grid]				[Diagram: 3x3 grid]				[Diagram: 4x3 grid]								3	1	3
2760	[Diagram: 2x3 grid]				[Diagram: 3x3 grid]				[Diagram: 4x3 grid]								2	2	3
2910	[Diagram: 2x3 grid]				[Diagram: 3x3 grid]				[Diagram: 4x3 grid]								1	2	3
3060	[Diagram: 2x3 grid]				[Diagram: 3x3 grid]				[Diagram: 4x3 grid]								*	3	3
3090	[Diagram: 2x4 grid]				[Diagram: 3x4 grid]				[Diagram: 4x4 grid]								1	*	1
3240	[Diagram: 2x4 grid]				[Diagram: 3x4 grid]				[Diagram: 4x4 grid]								2	1	2
3390	[Diagram: 2x4 grid]				[Diagram: 3x4 grid]				[Diagram: 4x4 grid]								3	1	3
3540	[Diagram: 2x4 grid]				[Diagram: 3x4 grid]				[Diagram: 4x4 grid]								4	2	4
3690	[Diagram: 2x4 grid]				[Diagram: 3x4 grid]				[Diagram: 4x4 grid]								3	2	4
3840	[Diagram: 2x4 grid]				[Diagram: 3x4 grid]				[Diagram: 4x4 grid]								2	3	4
3990	[Diagram: 2x4 grid]				[Diagram: 3x4 grid]				[Diagram: 4x4 grid]								1	3	4
4140	[Diagram: 2x4 grid]				[Diagram: 3x4 grid]				[Diagram: 4x4 grid]								*	4	4
3870	[Diagram: 2x5 grid]				[Diagram: 3x5 grid]				[Diagram: 4x5 grid]								1	*	1
4020	[Diagram: 2x5 grid]				[Diagram: 3x5 grid]				[Diagram: 4x5 grid]								2	1	2
4170	[Diagram: 2x5 grid]				[Diagram: 3x5 grid]				[Diagram: 4x5 grid]								3	1	3
4320	[Diagram: 2x5 grid]				[Diagram: 3x5 grid]				[Diagram: 4x5 grid]								4	2	4
4470	[Diagram: 2x5 grid]				[Diagram: 3x5 grid]				[Diagram: 4x5 grid]								5	2	5
4620	[Diagram: 2x5 grid]				[Diagram: 3x5 grid]				[Diagram: 4x5 grid]								4	3	5
4770	[Diagram: 2x5 grid]				[Diagram: 3x5 grid]				[Diagram: 4x5 grid]								3	3	5
4920	[Diagram: 2x5 grid]				[Diagram: 3x5 grid]				[Diagram: 4x5 grid]								2	4	5
5070	[Diagram: 2x5 grid]				[Diagram: 3x5 grid]				[Diagram: 4x5 grid]								1	4	5
5220	[Diagram: 2x5 grid]				[Diagram: 3x5 grid]				[Diagram: 4x5 grid]								*	5	5

Pit Clear Opening Lengths shown in Green cannot be achieved with a 900 Assist Lift Cover
Pit Clear Opening Lengths shown in Red cannot be achieved with a 750 Assist Lift Cover

Loading Group F900 - LFA

LFA F900

Materials

The components of Gatic LFA Assist lift covers are manufactured from the following materials: Ductile iron to BS EN 1563. M-Struts® and other parts in stainless steel grade 304.

Safe Lifting

Gatic LFA Assist lift covers have been designed to be lifted and closed by a single operator. The maximum lifting and closing force will be approximately 25kg.

M-Struts®

M-Struts® are designed for demanding environments and provide a maintenance free alternative to conventional gas struts. M-Struts® are made of grade 304 stainless steel. Unlike gas and pneumatic models, M-Struts® have no internal gases to leak or seals to fail in extreme conditions.

Loadings

Gatic LFA Assist lift covers will withstand the test load, deflection and maximum deformation criteria specified in BS EN 124 for load category F900. Gatic LFA Assist lift covers are suitable for installation in areas subject to slow moving traffic.

Features

- Automatic engaging mechanism to prevent accidental closure.
- Slam latch.
- Locking feature - single Allen key required for opening.
- Integrated lifting handle.
- For sealed Assist lift options please see page 28 - 35



Pit clear opening (mm)	Overall	Frame depth	Overall depth	Total weight	Load rating
750 x 750	983 x 958	118	142	202kg	F900

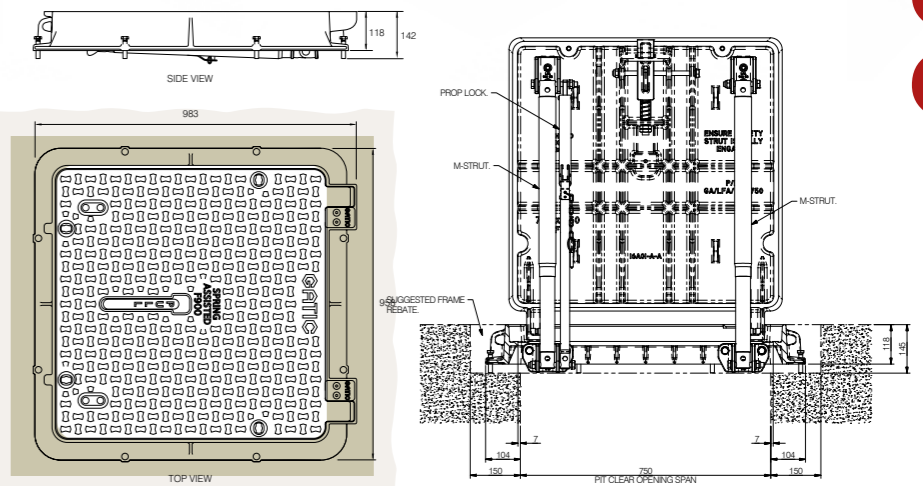

Pit clear opening (mm)	Overall	Frame depth	Overall depth	Total weight	Load rating
900 x 900	1133 x 1108	118	162	252kg	F900

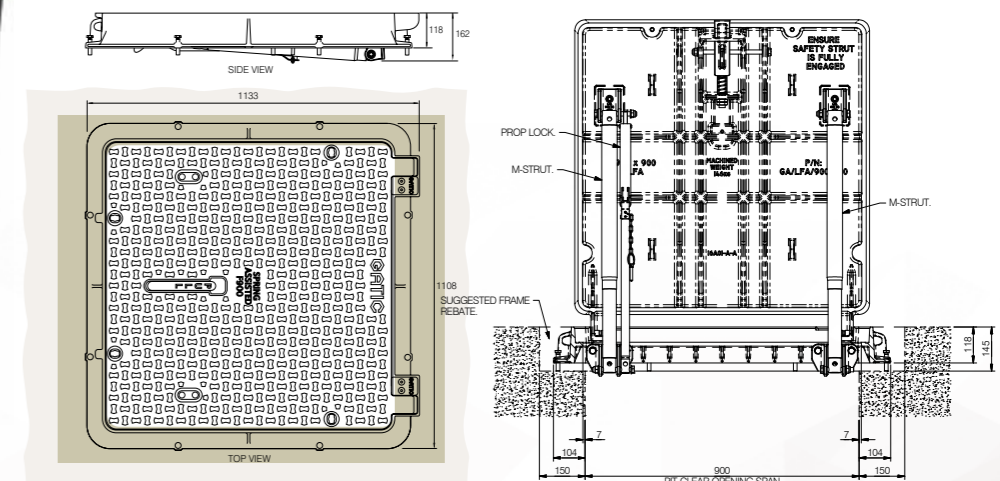

F900 LFA

Loading Group E600

AREAS OF HIGH WHEEL LOADS, SOME AIRCRAFT HARD-STANDINGS, DOCKYARDS AND OTHER AREAS WHERE HEAVY DUTY PLANT AND VEHICLES MAY BE USED

Introduction

This section includes Gatic covers and frames designed for Loading Group E600.

20 tonne wheel load, test load 600kN - Suitable for:

- Some airfield pavements dockyards
- Dockyards
- Other areas where single slow moving wheel loads up to 20 tonne may be encountered



E600 assemblies are available with a choice of cover designs - recessed or solid top.

Recessed for concrete infill

Recessed covers are available in a choice of designs designated by a 'Type' reference. E600 recessed covers are available as Type DLF, DM, DMR, DM/F, RRF. Section drawings of the different recessed cover types are shown on the following pages.



Solid top

Solid top cover types are lighter in weight than recessed covers, and feature an anti-slip surface.

Solid top covers are denoted by the code Type RSF depicted in section on the following pages.



To prevent movement of covers in high traffic conditions, we recommend the use of a factory fitted vibration-resistant locking system. These can be fitted to recessed covers only.

If you are uncertain as to the adequacy of covers conforming to a particular loading, we recommend specifying covers in a higher loading group. For example, if in doubt about covers in Loading Group E600, we recommend you specify covers in Loading Group F900.

E600

Single covers and frames



Duct covers and frames



Continuous trench covers and frames



Multispan covers and frames



Product Ranges

Loading Group E600

AREAS OF HIGH WHEEL LOADS, SOME AIRCRAFT HARD-STANDINGS, DOCKYARDS AND OTHER AREAS WHERE HEAVY DUTY PLANT AND VEHICLES MAY BE USED

E600

Single recessed covers and frames



- Covers recessed for concrete infill
 - Cover type: DLF, DMR, DM/F, DM, RRF
- To specify state:
- Loading group
 - Pit clear opening size length (L) x span (S)
 - Cover type

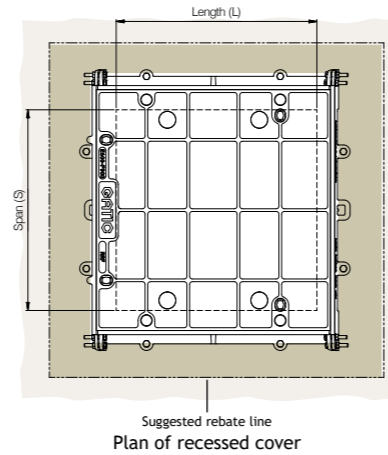

Pit clear opening sizes L x S	Cover type	Overall frame size length x width x depth	Suggested rebate size length x width x depth
750 x 300	DLF	900 x 540 x 75	1050 x 600 x 100
600 x 450	DMR	750 x 670 x 140	1000 x 850 x 165
750 x 450	DMR	900 x 670 x 140	1150 x 850 x 165
600 x 600	RRF	750 x 840 x 100	1000 x 1000 x 125
750 x 600	RRF	900 x 840 x 100	1150 x 1000 x 125
900 x 600	RRF	1050 x 840 x 100	1300 x 1000 x 125
750 x 750	RRF	900 x 990 x 100	1150 x 1150 x 125
900 x 750	RRF	1050 x 990 x 100	1300 x 1150 x 125
900 x 900	RRF	1120 x 1140 x 100	1300 x 1300 x 125
600 x 1050	DM	820 x 1270 x 140	1000 x 1450 x 165
750 x 1050	DM	970 x 1270 x 140	1150 x 1450 x 165
1000 x 1050	DM	1220 x 1270 x 140	1400 x 1450 x 165
600 x 1200	DM	820 x 1420 x 140	1000 x 1600 x 165
750 x 1200	DM	970 x 1420 x 140	1150 x 1600 x 165
600 x 1500	DM/F	820 x 1720 x 140	1000 x 1900 x 165
750 x 1500	DM/F	970 x 1720 x 140	1150 x 1900 x 165

E600

Single Solid top covers and frames



- Covers with solid top
 - Cover type RSF
- To specify state:
- Loading group
 - Pit clear opening size length (L) x span (S)
 - Cover type

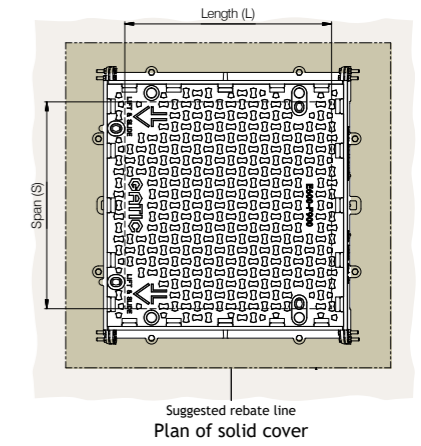

Pit clear opening sizes L x S	Cover type	Overall frame size length x width x depth	Suggested rebate size length x width x depth
600 x 600	RSF	750 x 840 x 100	1000 x 1000 x 125
750 x 600	RSF	900 x 840 x 100	1150 x 1000 x 125
900 x 600	RSF	1050 x 840 x 100	1300 x 1000 x 125
700 x 700	RSF	850 x 940 x 100	1100 x 1100 x 125
750 x 750	RSF	900 x 990 x 100	1150 x 1150 x 125
900 x 750	RSF	1050 x 990 x 100	1300 x 1150 x 125
900 x 900	RSF	1120 x 1140 x 100	1300 x 1300 x 125
1000 x 1000	RSF	1220 x 1240 x 100	1400 x 1400 x 125

Cover types

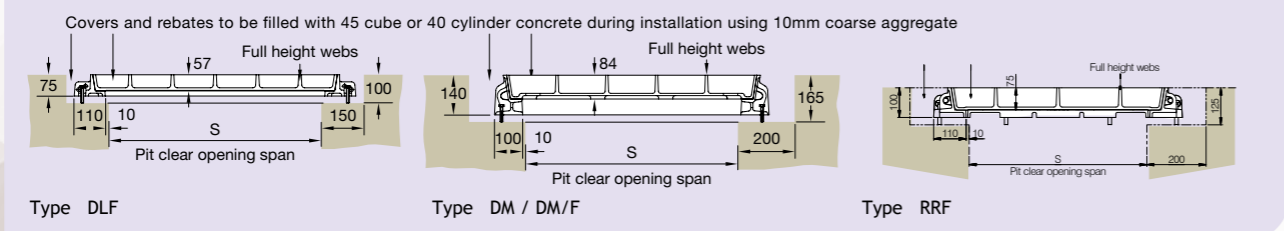

For high density traffic conditions refer to page 14.

Cover types

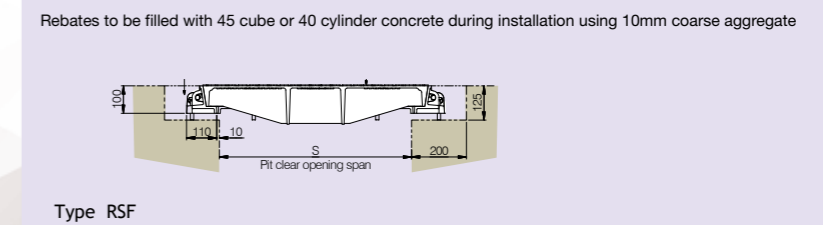

Loading Group E600

AREAS OF HIGH WHEEL LOADS, SOME AIRCRAFT HARD-STANDINGS, DOCKYARDS AND OTHER AREAS WHERE HEAVY DUTY PLANT AND VEHICLES MAY BE USED



- Covers recessed for concrete infill
- Cover type DLF, RRF, DMR, DM, DM/F

- To specify state:
1. Loading group
 2. Pit clear opening size length (L) x span (S)
 3. Cover type

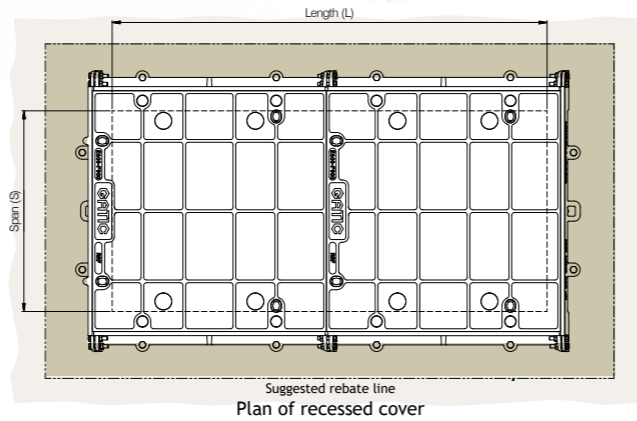

Pit clear opening sizes	Cover type	Suggested rebate size length x width x depth
300	DLF	(L + 300) x 600 x 100
450	DMR	(L + 400) x 850 x 165
600	RRF	(L + 400) x 1000 x 125
750	RRF	(L + 400) x 1150 x 125
900	RRF	(L + 400) x 1300 x 125
1050	DM	(L + 400) x 1450 x 165
1200	DM	(L + 400) x 1600 x 165
1500	DM/F	(L + 400) x 1900 x 165

Pit clear opening span (S)	Cover type	Standard pit clear opening length (L)											
		1300	1450	1600	1750	1900	2000	2150	2300	2450	2600	2700	2750
300	DLF	*	*	2	*	*	*	*	*	3	*	*	*
450	DMR	2	2	2	*	*	3	3	3	3	*	4	*
600	RRF	2	2	2	2	2	3	3	3	3	3	4	3
750	RRF	2	2	2	2	2	3	3	3	3	3	4	3
900	RRF	2	2	2	2	2	3	3	3	3	3	4	3
1050	DM	2	2	2	*	*	3	3	3	3	*	4	*
1200	DM	2	2	2	*	*	3	3	3	3	*	4	*
1500	DM/F	2	2	2	*	*	3	3	3	3	*	4	*

Pit clear opening span (S)	Cover type	Standard pit clear opening length (L)											
		2850	2900	3000	3150	3300	3400	3550	3700	3850	3900	4000	4150
300	DLF	*	*	*	*	4	*	*	*	*	*	*	5
450	DMR	4	*	4	4	4	5	5	5	5	*	5	5
600	RRF	4	3	4	4	4	5	5	5	5	4	5	5
750	RRF	4	3	4	4	4	5	5	5	5	4	5	5
900	RRF	4	3	4	4	4	5	5	5	5	4	5	5
1050	DM	4	*	4	4	4	5	5	5	5	*	5	5
1200	DM	4	*	4	4	4	5	5	5	5	*	5	5
1500	DM/F	4	*	4	4	4	5	5	5	5	*	5	5

Cover types

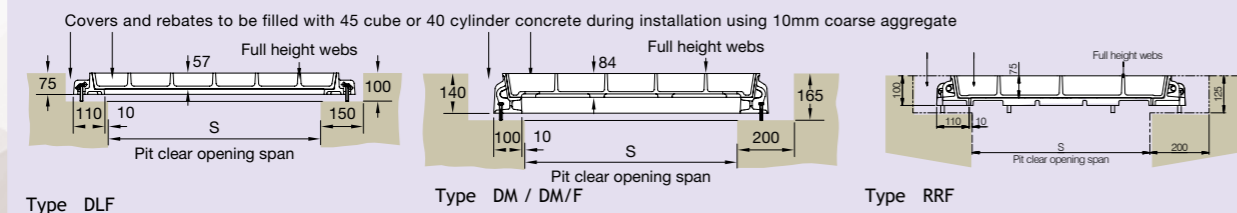

* Indicates standard sizes not available. The number shown indicates the quantity of cover parts. Other standard sizes may be available, refer to our technical department.

Cover types

Rebates to be filled with 45 cube or 40 cylinder concrete during installation using 10mm coarse aggregate

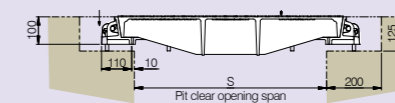

Type RSF

* Indicates standard sizes not available. The number shown indicates the quantity of cover parts. Other standard sizes may be available, refer to our technical department.



- Covers with solid top
- Cover type RSF

- To specify state:
1. Loading group
 2. Pit clear opening size length (L) x span (S)
 3. Cover type

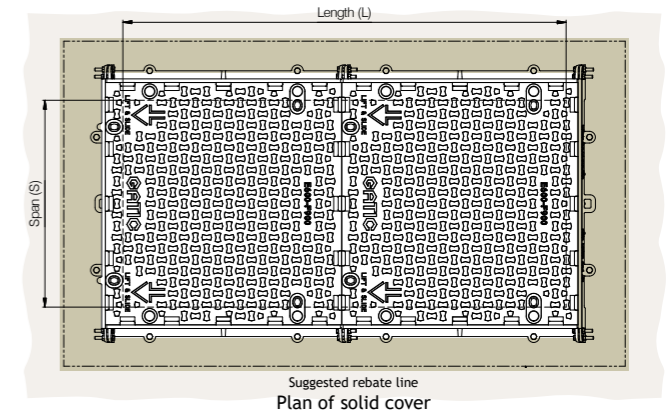

Pit clear opening sizes	Cover type	Suggested rebate size length x width x depth
600	RSF	(L + 400) x 1000 x 125
700	RSF	(L + 400) x 1100 x 125
750	RSF	(L + 400) x 1150 x 125
900	RSF	(L + 400) x 1300 x 125

For high density traffic conditions refer to page 14.

Pit clear opening span (S)	Cover type	Standard pit clear opening length (L)												
		1300	1450	1500	1600	1750	1900	2000	2150	2300	2450	2600	2700	2750
600	RSF	2	2	*	2	2	2	3	3	3	3	3	4	3
700	RSF	*	*	2	*	*	*	*	*	3	*	*	*	*
750	RSF	2	2	*	2	2	2	3	3	3	3	3	4	3
900	RSF	2	2	*	2	2	2	3	3	3	3	3	4	3

Pit clear opening span (S)	Cover type	Standard pit clear opening length (L)												
		2850	2900	3000	3100	3150	3300	3400	3550	3700	3850	3900	4000	4150
600	RSF	4	3	4	*	4	4	5	5	5	5	4	5	5
700	RSF	*	*	*	4	*	*	*	*	*	*	5	*	*
750	RSF	4	3	4	*	4	4	5	5	5	5	4	5	5
900	RSF	4	3	4	*	4	4	5	5	5	5	4	5	5

Loading Group E600

AREAS OF HIGH WHEEL LOADS, SOME AIRCRAFT HARD-STANDINGS, DOCKYARDS AND OTHER AREAS WHERE HEAVY DUTY PLANT AND VEHICLES MAY BE USED

- Covers recessed for concrete infill
 - Cover types: DLF, DM, DMR, DM/F, RRF
- To specify state:
- Loading group
 - Cover type
 - Supply layout drawing of trenches

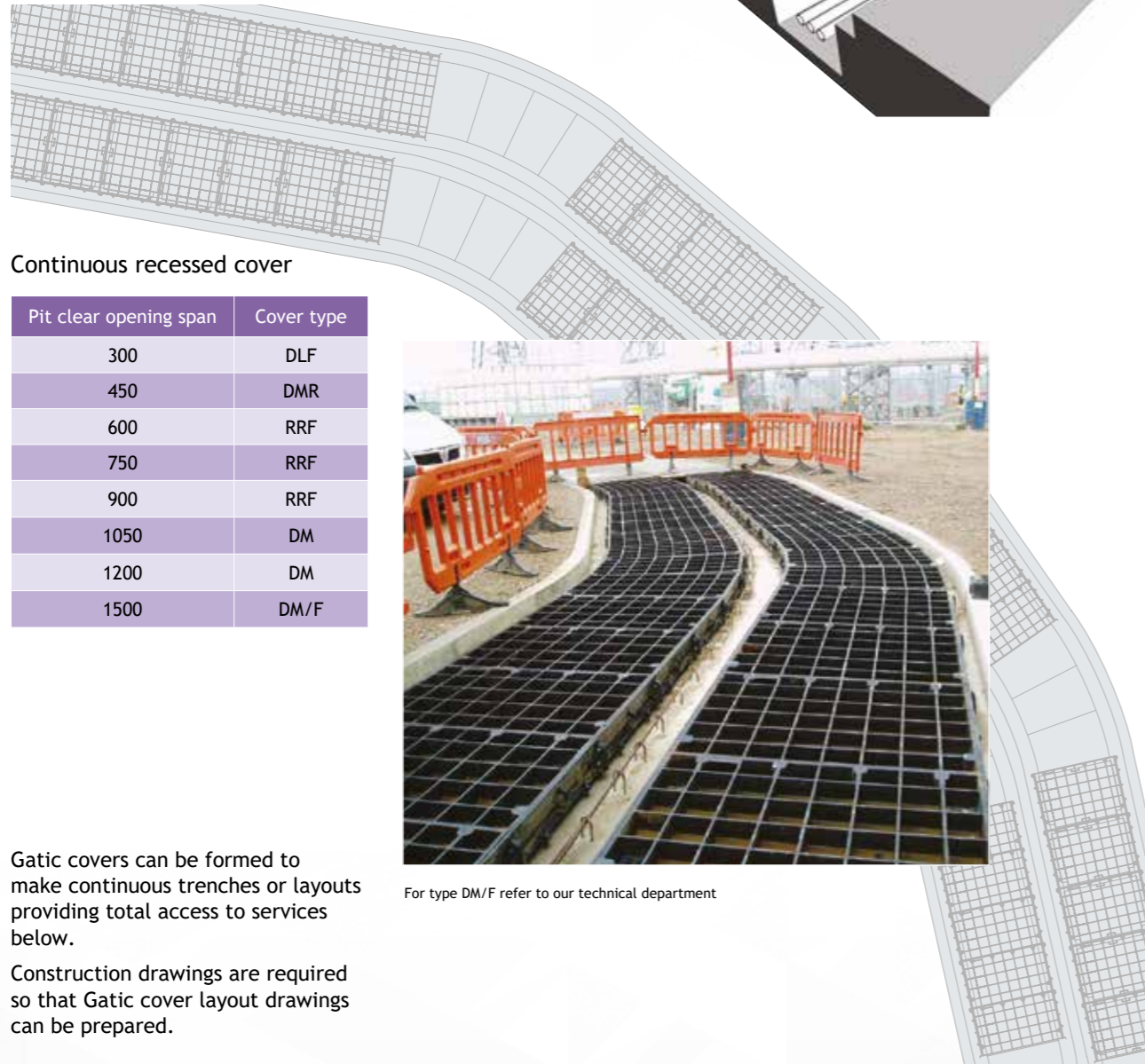
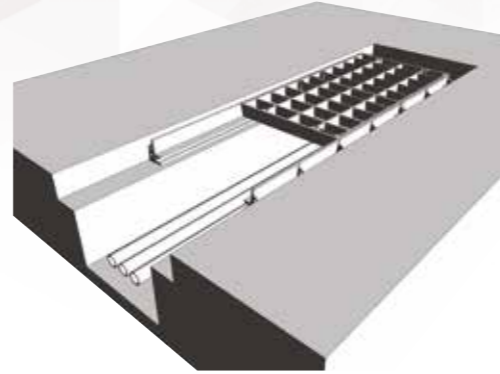

Continuous recessed cover

Pit clear opening span	Cover type
300	DLF
450	DMR
600	RRF
750	RRF
900	RRF
1050	DM
1200	DM
1500	DM/F



For type DM/F refer to our technical department

Gatic covers can be formed to make continuous trenches or layouts providing total access to services below.

Construction drawings are required so that Gatic cover layout drawings can be prepared.

Cover types

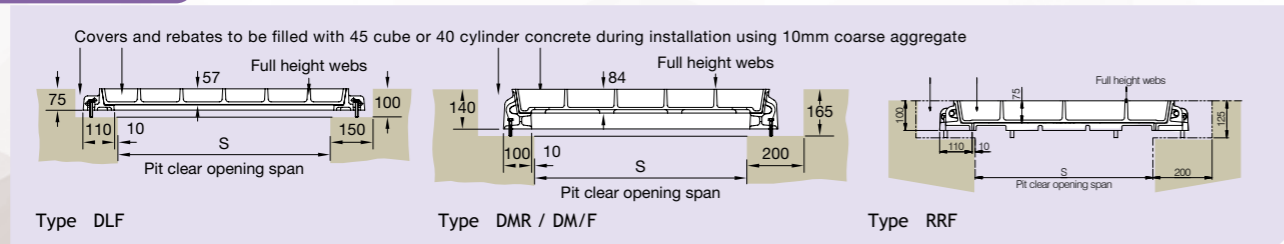

Continuous solid top cover

Pit clear opening span	Cover type
600	RSF
700	RSF
750	RSF
900	RSF

For high density traffic conditions refer to page 14.

Standard Solid top covers are supplied in straight runs. Junctions and splays can be achieved by the inclusion of localised recessed covers. Refer to our technical department for more information.

- Covers with solid top
 - Cover types: RSF
- To specify state:
- Loading group
 - Cover type
 - Supply layout drawing of trenches

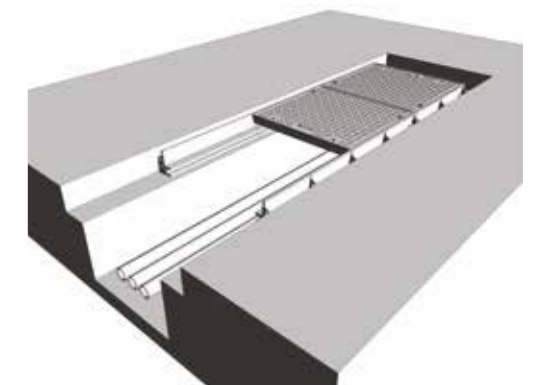

Cover types

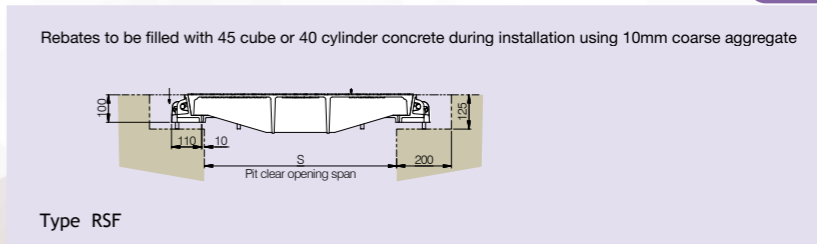

Loading Group E600

AREAS OF HIGH WHEEL LOADS, SOME AIRCRAFT HARD-STANDINGS, DOCKYARDS AND OTHER AREAS WHERE HEAVY DUTY PLANT AND VEHICLES MAY BE USED

Specification

Below is a sample specification information and notes for Multispan recessed covers and frames.

For more details on features and benefits of Gatic covers see pages 14

Loading group Gatic E600

20 tonne wheel load - test load 600 kN.

Materials

Ductile iron components to BS EN 1563.

Structural steel removable beams to BS EN 10365.

Finishes

Units coated with black bituminous solution for protection during transit.

Removable supporting steelwork galvanised to BS EN ISO 1461.

Infill and surround concrete by customer

Concrete strength, using 10mm down coarse aggregate, to be: 45N/mm² for a test cube of 150mm or 40N/mm² for a test cylinder of 150mm diameter x 300mm high.

Installation

In accordance with instructions supplied by Gatic.

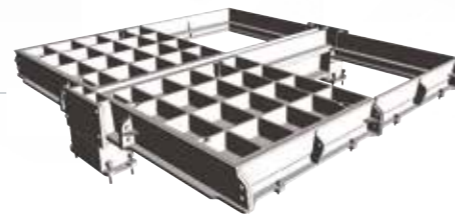

Type RRF recessed



Type RSF solid top

To specify use size and description format as follows:

Gatic Multispan Recessed covers and frames Cover type RRF recessed

Multiple access covers recessed for concrete infill with removable beams.

.... in no. (length) x (span) mm pit clear opening multi span cover and frame.

Gatic Type DMR Ductile Iron Recessed Cover in parts complete with

.... in no. x mm galvanised removable support beam spanning the (length) mm way.

Suitable for Loading Group E600 - 20 Tonnes Wheel Load (pneumatic tyre).

Gatic Multispan Solid Top covers and frames Cover type RSF solid top

Multiple solid top access covers with removable beams.

.... in no. (length) x (span) mm pit clear opening multi span cover and frame.

Gatic Type RSF Ductile Iron Solid Top Cover in parts complete with

.... in no. x mm galvanised removable support beam spanning the (length) mm way.

Suitable for Loading Group E600 - 20 Tonnes Wheel Load (pneumatic tyre).

Standard pit clear opening sizes are shown on page 45

Beam sizes and other dimensions are shown on page 46 - 47

For high density traffic conditions refer to page 14.

Product Selection

Refer to the table to identify which cover and beam configuration you require against pit clear opening length (L) and pit clear opening span (S). All dimensions are in millimetres.

Note: All dimensions shown in red are made up using 700 x 700 solid top covers only.

		Pit clear opening length (L) mm									Beam centres mm																				
		2 parts			3 parts			4 parts			A	B	C	D	E																
Pit clear opening span (S) mm	2 parts 1 beam	1380	1450	1500	1600	1750	1900	2000	2150	2300	2450	2600	2750	2900	2700	2850	3000	3150	3300	3450	3600	3750	3900								
		1530	1580	1680	1830	1980	2160	2310	2460	2610	2760	2910	3060	2940	3090	3240	3390	3540	3690	3840	3990	4140									
		1830	1980	2130	2280	2430	2580	2730	2880	3030	3180	3330	3480	3630	3780	3930	4080	4230	4380	4530	4680	4830	4980								
	3 parts 2 beams	2160	2310	2460	2610	2760	2910	3060	3210	3360	3510	3660	3810	3960	4110	4260	4410	4560	4710	4860	5010	5160	5310	5460							
		2460	2610	2760	2910	3060	3210	3360	3510	3660	3810	3960	4110	4260	4410	4560	4710	4860	5010	5160	5310	5460	5610	5760							
		2760	2910	3060	3210	3360	3510	3660	3810	3960	4110	4260	4410	4560	4710	4860	5010	5160	5310	5460	5610	5760	5910	6060							
	4 parts 3 beams	2940	3090	3240	3390	3540	3690	3840	3990	4140	4290	4440	4590	4740	4890	5040	5190	5340	5490	5640	5790	5940	6090	6240	6390						
		3090	3240	3390	3540	3690	3840	3990	4140	4290	4440	4590	4740	4890	5040	5190	5340	5490	5640	5790	5940	6090	6240	6390	6540	6690					
		3240	3390	3540	3690	3840	3990	4140	4290	4440	4590	4740	4890	5040	5190	5340	5490	5640	5790	5940	6090	6240	6390	6540	6690						
	5 parts 4 beams	3720	3870	4020	4170	4320	4470	4620	4770	4920	5070	5220	5370	5520	5670	5820	5970	6120	6270	6420	6570	6720	6870	7020	7170						
		3870	4020	4170	4320	4470	4620	4770	4920	5070	5220	5370	5520	5670	5820	5970	6120	6270	6420	6570	6720	6870	7020	7170	7320	7470					
		4020	4170	4320	4470	4620	4770	4920	5070	5220	5370	5520	5670	5820	5970	6120	6270	6420	6570	6720	6870	7020	7170	7320	7470						

Note: For other pit clear opening sizes please refer to our technical department

E600 Multispan covers and frames

E600 Multispan covers and frames

Loading Group E600

AREAS OF HIGH WHEEL LOADS, SOME AIRCRAFT HARD-STANDINGS, DOCKYARDS AND OTHER AREAS WHERE HEAVY DUTY PLANT AND VEHICLES MAY BE USED



Type RRF recessed



Type RSF solid top

- Covers recessed for concrete infill or solid top
- Cover types: RRF (recessed) RSF (solid top)

The details below show plan and sections of a typical recessed/solid top unit.

For selection and specification guidance See page 44.

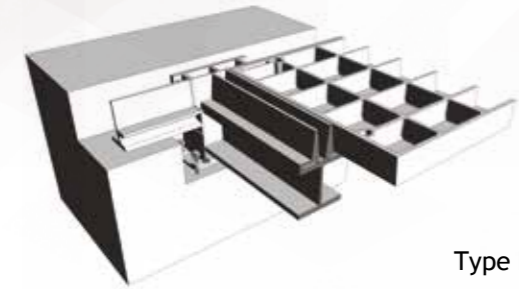
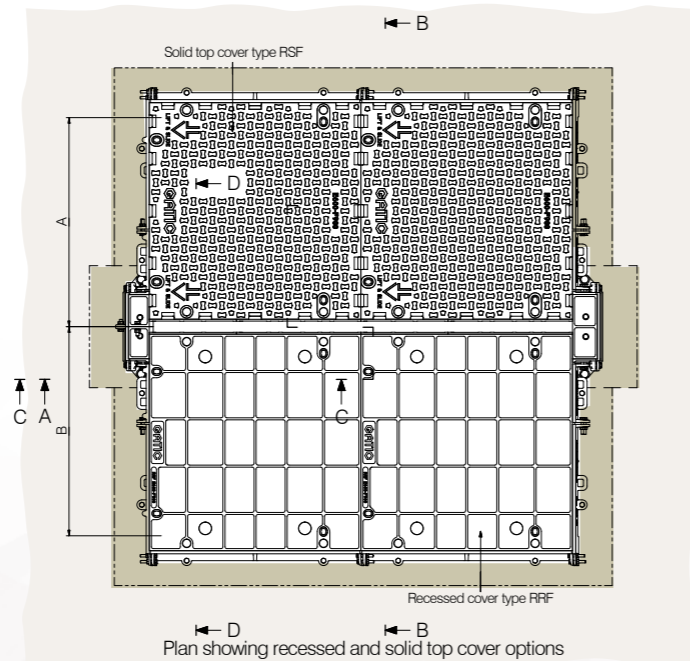
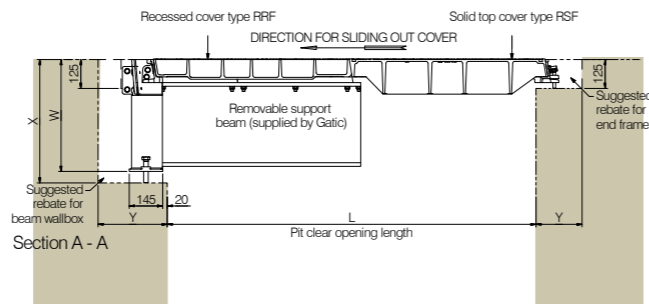
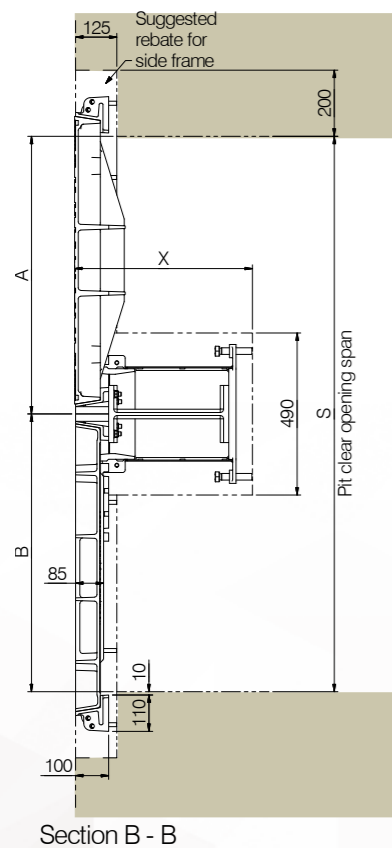

Type RRF recessed

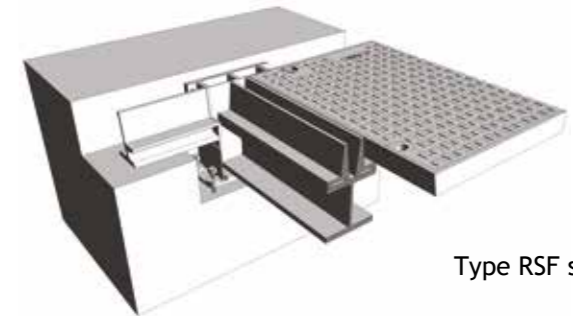

Type RSF solid top

Beam Size

The required beam size for Multispan covers is dependent on the pit clear opening length and the loading group.

The table shows maximum beam length against beam size. The removable support beams are supplied by Gatic.

The table also indicates dimensions of the beam wallbox and rebate to suit different beam sizes. See also the accompanying section details.

Support beam size chart

Removable support beam size	Max pit clear opening length (L)	Beam wallbox dimensions			
		V	W	X	Y
305 x 165 x 54 kg/m U.B	2000	412	434	480	230
356 x 171 x 67 kg/m U.B	2450	465	487	535	300
457 x 152 x 82 kg/m U.B	2850	568	590	635	300
533 x 210 x 122 kg/m U.B	3900	647	669	715	300

Note: Removable support beams are supplied by Gatic

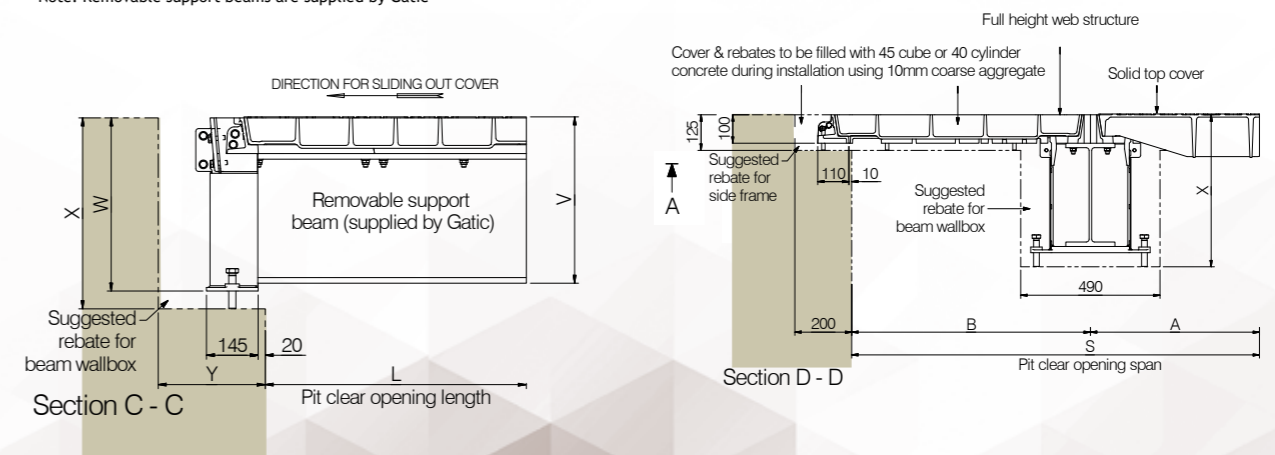

E600

Recessed duct covers and frames

E600

Solid top duct covers and frames

Loading Group D400

POWER STATIONS, CARRIAGEWAYS, HARD SHOULDERS, AND PARKING AREAS FOR ALL TYPES OF VEHICLE

Introduction

This section includes Gatic covers and frames designed for Loading Group D400.

11.5 tonne wheel load, test load 400kN - Suitable for:

- Power stations
- Carriageways
- Hard shoulders
- Parking areas for all types of vehicles



To prevent movement of covers in high traffic conditions, we recommend the use of a factory fitted vibration-resistant locking system. Can be fitted to recessed concrete infill covers only.

If you are uncertain as to the adequacy of covers conforming to a particular loading, we recommend specifying covers in a higher loading group. For example, if in doubt about covers in Loading Group D400, we recommend you specify covers in Loading Group E600.

D400 assemblies are available with a choice of cover designs - recessed or solid top.

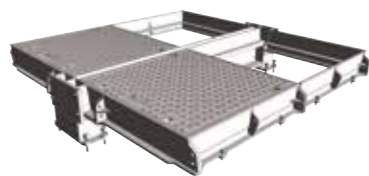

Recessed for concrete infill

Recessed covers are available in a choice of designs designated by a 'Type' reference. D400 recessed covers are available as Type DLF, DM/F, DMR, RRD. Section drawings of the different recessed cover types are shown on the following pages.

Solid top

Solid top cover types are lighter in weight than recessed covers, and feature an anti-slip surface. Solid top covers are denoted by the code Type RSD depicted in section on the following pages.

Gatic Pave

Gatic Pave is a comprehensive system of single, duct and multi span access covers and frames for use in paved areas where an aesthetic finish is required in environments up to D400 loading.

D400

Product Ranges

Single covers and frames



Duct covers and frames



PAVE



Continuous trench covers and frames



Multispan covers and frames



Loading Group D400

POWER STATIONS, CARRIAGEWAYS, HARD SHOULDERS, AND PARKING AREAS FOR ALL TYPES OF VEHICLE

D400

Single recessed covers and frames



- Covers recessed for concrete infill
 - Cover type: DLF, DM, DMR, RRD, DM/F
- To specify state:
- Loading group
 - Pit clear opening size length (L) x span (S)
 - Cover type

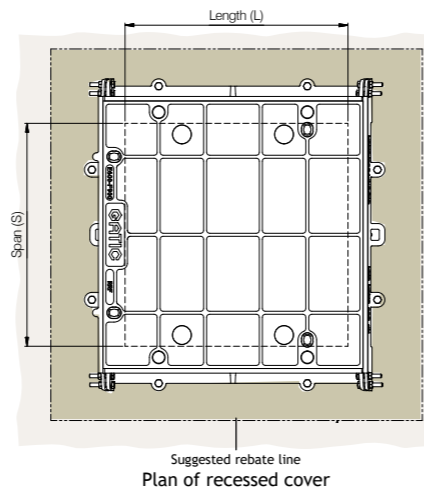

Pit clear opening sizes L x S	Cover type	Overall frame size length x width x depth	Suggested rebate size length x width x depth
750 x 300	DLF	900 x 540 x 75	1050 x 600 x 100
600 x 450	DMR	750 x 670 x 140	1000 x 850 x 165
750 x 450	DMR	900 x 670 x 140	1150 x 850 x 165
600 x 600	RRD	750 x 840 x 100	1000 x 1000 x 125
750 x 600	RRD	900 x 840 x 100	1150 x 1000 x 125
900 x 600	RRD	1050 x 840 x 100	1300 x 1000 x 125
750 x 750	RRD	900 x 990 x 100	1150 x 1150 x 125
900 x 750	RRD	1050 x 990 x 100	1300 x 1150 x 125
900 x 900	RRD	1120 x 1140 x 100	1300 x 1300 x 125
600 x 1050	DM	820 x 1270 x 140	1000 x 1450 x 165
750 x 1050	DM	970 x 1270 x 140	1150 x 1450 x 165
1000 x 1050	DM	1220 x 1270 x 140	1400 x 1450 x 165
600 x 1200	DM	820 x 1420 x 140	1000 x 1600 x 165
750 x 1200	DM	970 x 1420 x 140	1150 x 1600 x 165
600 x 1500	DM/F	820 x 1720 x 140	1000 x 1900 x 165
750 x 1500	DM/F	970 x 1720 x 140	1150 x 1900 x 165

D400

Single solid top covers and frames



- Covers with solid top
 - Cover type RSD
- To specify state:
- Loading group
 - Pit clear opening size length (L) x span (S)
 - Cover type



Pit clear opening sizes L x S	Cover type	Overall frame size length x width x depth	Suggested rebate size length x width x depth
600 x 600	RSD	750 x 840 x 100	1000 x 1000 x 125
750 x 600	RSD	900 x 840 x 100	1150 x 1000 x 125
900 x 600	RSD	1050 x 840 x 100	1300 x 1000 x 125
700 x 700	RSD	850 x 940 x 100	1100 x 1100 x 125
750 x 750	RSD	900 x 990 x 100	1150 x 1150 x 125
900 x 750	RSD	1050 x 990 x 100	1300 x 1150 x 125
900 x 900	RSD	1120 x 1140 x 100	1300 x 1300 x 125
600 x 1200	RSD	820 x 1420 x 100	1000 x 1600 x 125
750 x 1200	RSD	970 x 1420 x 100	1150 x 1600 x 125
1000 x 1000	RSD	1220 x 1240 x 100	1400 x 1400 x 125

For high density traffic conditions refer to page 14.

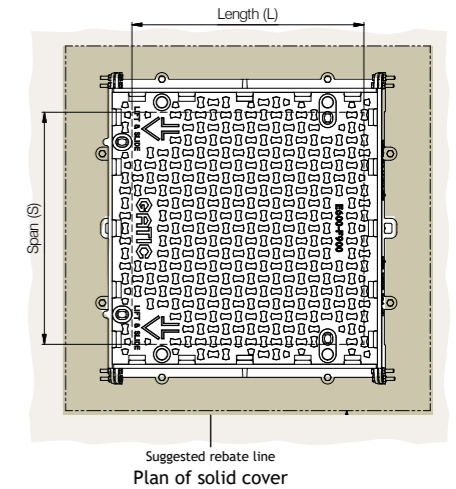

Cover types

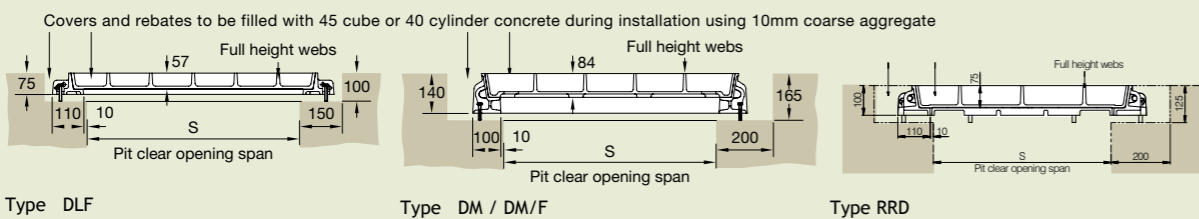

Cover types

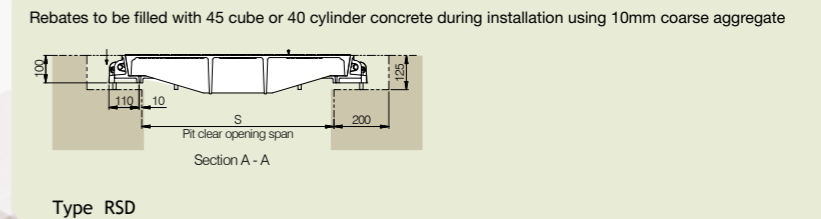

Loading Group D400

POWER STATIONS, CARRIAGEWAYS, HARD SHOULDERS, AND PARKING AREAS FOR ALL TYPES OF VEHICLE



- Covers recessed for concrete infill
- Cover type DLF, DM, DMR, RRD, DM/F

To specify state:
 1. Loading group
 2. Pit clear opening size length (L) x span (S)
 3. Cover type



Pit clear opening sizes	Cover type	Suggested rebate size length x width x depth
300	DLF	(L + 300) x 600 x 100
450	DMR	(L + 400) x 850 x 165
600	RRD	(L + 400) x 1000 x 125
750	RRD	(L + 400) x 1150 x 125
900	RRD	(L + 400) x 1300 x 125
1050	DM	(L + 400) x 1450 x 165
1200	DM	(L + 400) x 1600 x 165
1500	DM/F	(L + 400) x 1900 x 165

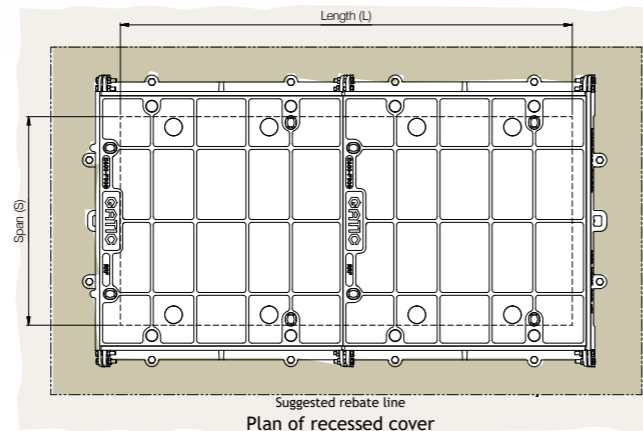

Pit clear opening span (S)	Cover type	Standard pit clear opening length (L)											
		1300	1450	1600	1750	1900	2000	2150	2300	2450	2600	2700	2750
300	DLF	*	*	2	*	*	*	*	*	3	*	*	*
450	DMR	2	2	2	*	*	3	3	3	3	*	4	*
600	RRD	2	2	2	2	2	3	3	3	3	3	4	3
750	RRD	2	2	2	2	2	3	3	3	3	3	4	3
900	RRD	2	2	2	2	2	3	3	3	3	3	4	3
1050	DM	2	2	2	*	*	3	3	3	3	*	4	*
1200	DM	2	2	2	*	*	3	3	3	3	*	4	*

Pit clear opening span (S)	Cover type	Standard pit clear opening length (L)											
		2850	2900	3000	3150	3300	3400	3550	3700	3850	3900	4000	4150
300	DLF	*	*	*	*	4	*	*	*	*	*	*	5
450	DMR	4	*	4	4	4	5	5	5	5	*	5	5
600	RRD	4	3	4	4	4	5	5	5	5	4	5	5
750	RRD	4	3	4	4	4	5	5	5	5	4	5	5
900	RRD	4	3	4	4	4	5	5	5	5	4	5	5
1050	DM	4	*	4	4	4	5	5	5	5	*	5	5
1200	DM	4	*	4	4	4	5	5	5	5	*	5	5

Cover types

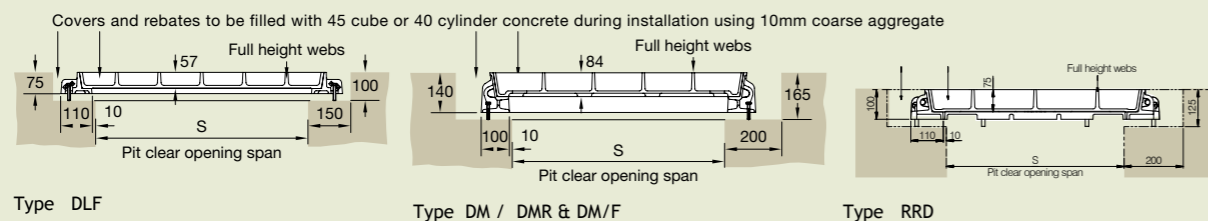

- Covers with solid top
- Cover type RSD

To specify state:
 1. Loading group
 2. Pit clear opening size length (L) x span (S)
 3. Cover type



Pit clear opening sizes	Cover type	Suggested rebate size length x width x depth
600	RSD	(L + 400) x 1000 x 125
700	RSD	(L + 400) x 1100 x 125
750	RSD	(L + 400) x 1150 x 125
900	RSD	(L + 400) x 1300 x 125
1200	RSD	(L + 400) x 1600 x 125

For high density traffic conditions refer to page 14.

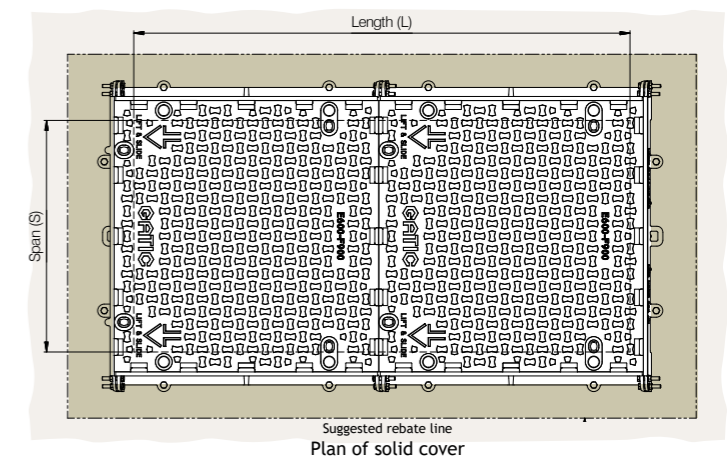

Pit clear opening span (S)	Cover type	Standard pit clear opening length (L)												
		1300	1450	1500	1600	1750	1900	2000	2150	2300	2450	2600	2700	2750
600	RSD	2	2	*	2	2	2	3	3	3	3	3	4	3
700	RSD	*	*	2	*	*	*	*	*	3	*	*	*	*
750	RSD	2	2	*	2	2	2	3	3	3	3	3	4	3
900	RSD	2	2	*	2	2	2	3	3	3	3	3	4	3
1200	RSD	2	2	*	2	*	*	3	3	3	3	*	4	*

Pit clear opening span (S)	Cover type	Standard pit clear opening length (L)												
		2850	2900	3000	3100	3150	3300	3400	3550	3700	3850	3900	4000	4150
600	RSD	4	3	4	*	4	4	5	5	5	5	4	5	5
700	RSD	*	*	*	4	*	*	*	*	*	*	5	*	*
750	RSD	4	3	4	*	4	4	5	5	5	5	4	5	5
900	RSD	4	3	4	*	4	4	5	5	5	5	4	5	5
1200	RSD	4	*	4	*	4	4	5	5	5	5	*	5	5

Cover types

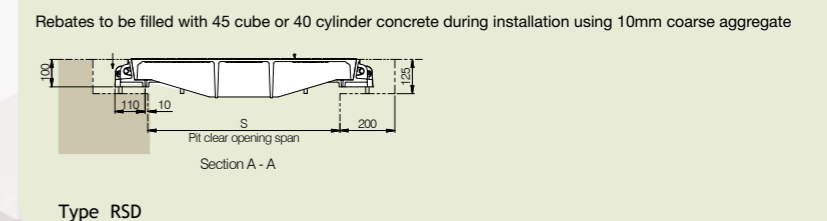

Loading Group D400 POWER STATIONS, CARRIAGEWAYS, HARD SHOULDERS, AND PARKING AREAS FOR ALL TYPES OF VEHICLE

D400



Continuous recessed cover

- Covers recessed for concrete infill
- Cover types: DLF, DM, RRD, DM/F, DMR

To specify state:

1. Loading group
2. Cover type
3. Supply layout drawing of trenches

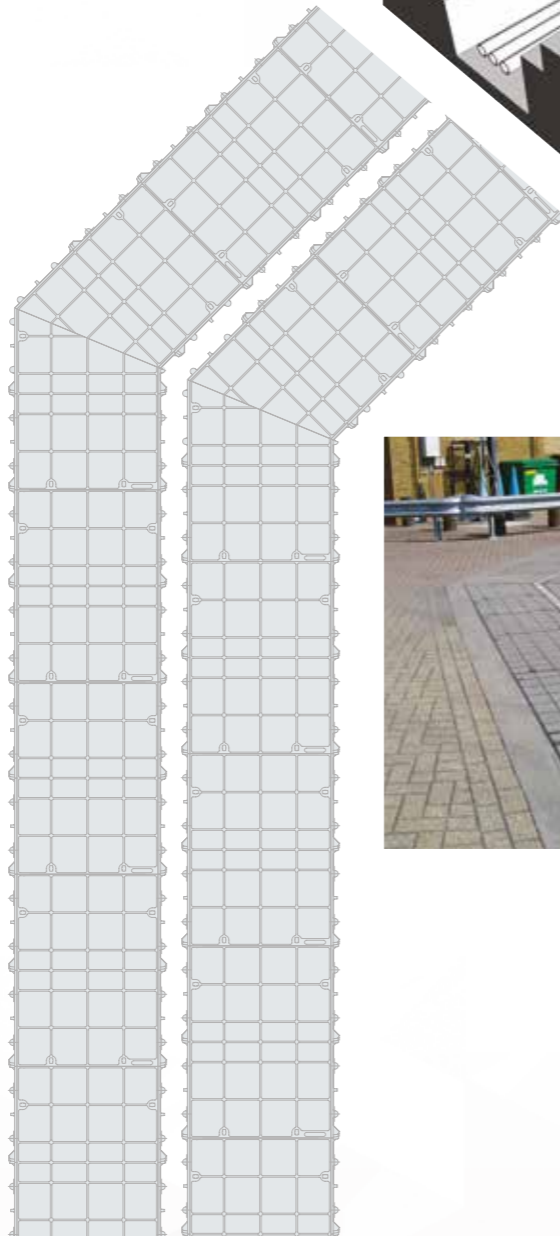
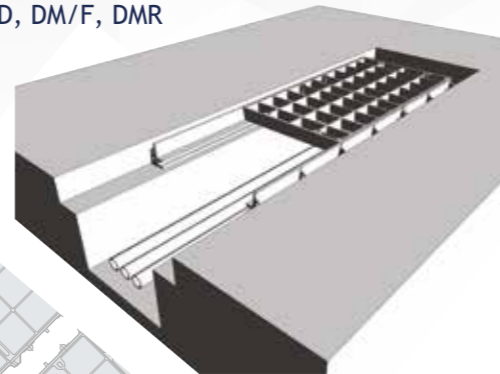

Pit clear opening span	Cover type
300	DLF
450	DMR
600	RRD
750	RRD
900	RRD
1050	DM
1200	DM
1500	DM/F

* For type DM/F refer to our technical department

Gatic covers can be formed to make continuous trenches or layouts providing total access to services below.

Construction drawings are required so that Gatic cover layout drawings can be prepared.



Cover types

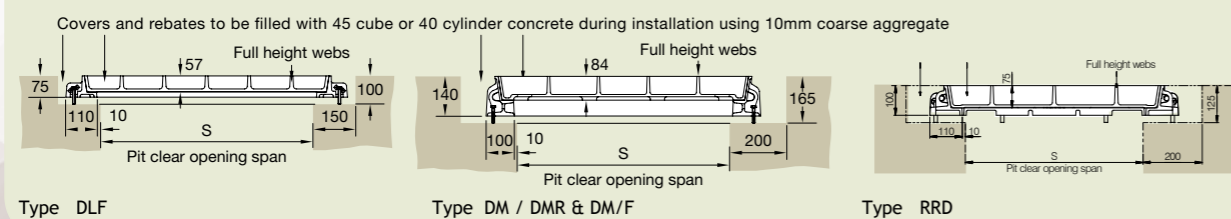

D400

Continuous solid top trench covers and frames

- Covers with solid top
- Cover types: RSD

To specify state:

1. Loading group
2. Cover type
3. Supply layout drawing of trenches

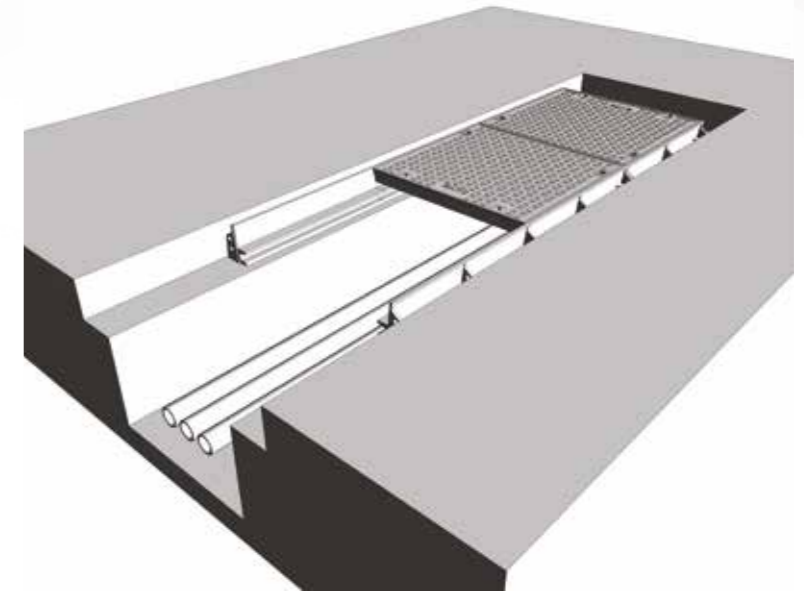

Continuous solid top cover

Pit clear opening span	Cover type
600	RSD
700	RSD
750	RSD
900	RSD
1200	RSD

Standard solid top covers are supplied in straight runs. Junctions and splays can be achieved by the inclusion of localised recessed covers. Refer to our technical department for more information.

For high density traffic conditions refer to page 14.



Cover types

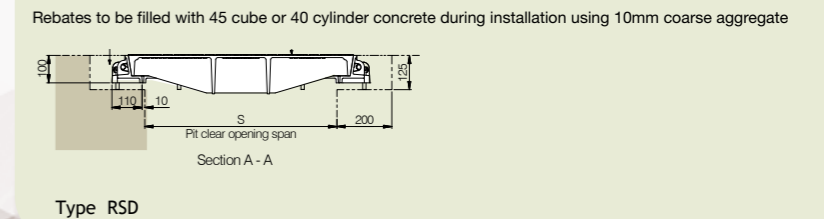

Loading Group D400 POWER STATIONS, CARRIAGEWAYS, HARD SHOULDERS, AND PARKING AREAS FOR ALL TYPES OF VEHICLE

Specification

Below is a sample specification information and notes for Multispan recessed covers and frames.

For more details on features and benefits of Gatic covers, see pages 14 to 15.

Loading group Gatic D400

11.5 tonne wheel load - test load 400 kN.

Materials

Ductile iron components to BS EN 1563.

Structural steel removable beams to BS EN 10365.

Finishes

Units coated with black bituminous solution for protection during transit.

Removable supporting steelwork galvanised to BS EN ISO 1461.

Infill and surround concrete by customer

Concrete strength, using 10mm down coarse aggregate, to be: 45N/mm² for a test cube of 150mm or 40N/mm² for a test cylinder of 150mm diameter x 300mm high.

Installation

In accordance with instructions supplied by Gatic.



Type RRD recessed



Type RSD solid top

To specify use size and description format as follows:

Gatic Multispan Recessed covers and frames Cover type RRD recessed

Multiple access covers recessed for concrete infill with removable beams.

.... in no. (length) x (span) mm pit clear opening multi span cover and frame.
Gatic Type RRD Ductile Iron Recessed Cover in parts complete with
.... in no. x mm galvanised removable support beam spanning the (length) mm way.
Suitable for Loading Group D400 - 11.5 Tonnes Wheel Load (pneumatic tyre).

Gatic Multispan Solid Top covers and frames Cover type RSD solid top

Multiple solid top access covers with removable beams.

.... in no. (length) x (span) mm pit clear opening multi span cover and frame.
Gatic Type RSD Ductile Iron Solid Top Cover in parts complete with
.... in no. x mm galvanised removable support beam spanning the (length) mm way.
Suitable for Loading Group D400 - 11.5 Tonnes Wheel Load (pneumatic tyre).

Standard pit clear opening sizes are shown on page 57.

Beam sizes and other dimensions are shown on page 58 - 59.

For high density traffic conditions refer to page 14.

Product Selection

Refer to the table to identify which cover and beam configuration you require against pit clear opening length (L) and pit clear opening span (S). All dimensions are in millimetres.

Pit clear opening span (S) mm	Pit clear opening length (L) mm												Beam centres mm																
	2 parts			3 parts			4 parts																						
	1300	1450	1600	1750	1900	2000	2150	2300	2450	2600	2750	2900	2700	2850	3000	3150	3300	3450	3600	3750	3900	A	B	C	D	E			
1380	4 part (2x2) multispan cover with 1 removable support beam			6 part (3x2) multispan cover with 1 removable support beam			8 part (4x2) multispan cover with 1 removable support beam								690	690													
1530															840	690													
1680															840	840													
1830															990	840													
1980															990	990													
2160	6 part (2x3) multispan cover with 2 removable support beam			9 part (3x3) multispan cover with 2 removable support beam			12 part (4x3) multispan cover with 2 removable support beam								690	780	690												
2310															690	930	690												
2460															840	780	840												
2610															840	930	840												
2760															840	1080	840												
2910															990	930	990												
3060															990	1080	990												
2940	8 part (2x4) multispan cover with 3 removable support beam			12 part (3x4) multispan cover with 3 removable support beam			16 part (4x4) multispan cover with 3 removable support beam								690	780	780	690											
3090															840	780	780	690											
3240															840	780	780	840											
3390															840	930	930	690											
3540															840	930	930	840											
3690															990	930	930	840											
3840															990	930	930	990											
3990															990	1080	1080	840											
4140															990	1080	1080	990											
3720	10 part (2x5) multispan cover with 4 removable support beam			15 part (3x5) multispan cover with 4 removable support beam			20 part (4x5) multispan cover with 4 removable support beam								690	780	780	780	690										
3870															690	780	930	780	690										
4020															840	780	780	780	840										
4170															690	930	930	930	690										
4320															840	930	780	930	840										
4470															840	930	930	930	840										
4620															840	930	1080	930	840										
4770															990	930	930	930	990										
4920															990	930	1080	930	990										
5070															990	1080	930	1080	990										
5220															990	1080	1080	1080	990										

Note: For other pit clear opening sizes please refer to our technical department

Loading Group D400

POWER STATIONS, CARRIAGEWAYS, HARD SHOULDERS, AND PARKING AREAS FOR ALL TYPES OF VEHICLE

D400

Multispan covers and frames



Type RRD recessed



Type RSD solid top

- Covers recessed for concrete infill or solid top
- Cover types: RRD (recessed) RSD (solid top)

The details below show plan and sections of a typical recessed/solid top unit.

For selection and specification guidance, refer to page 56.

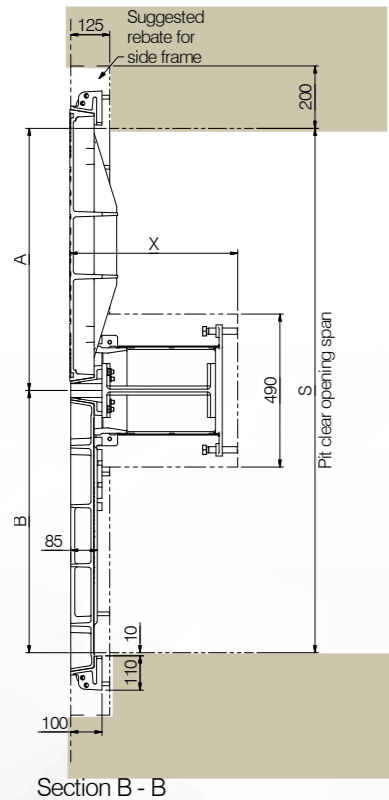

Section B - B

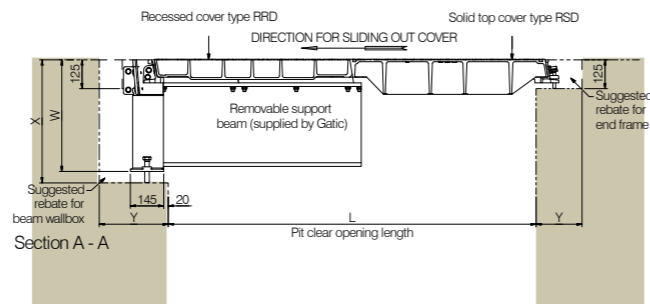

Section A - A

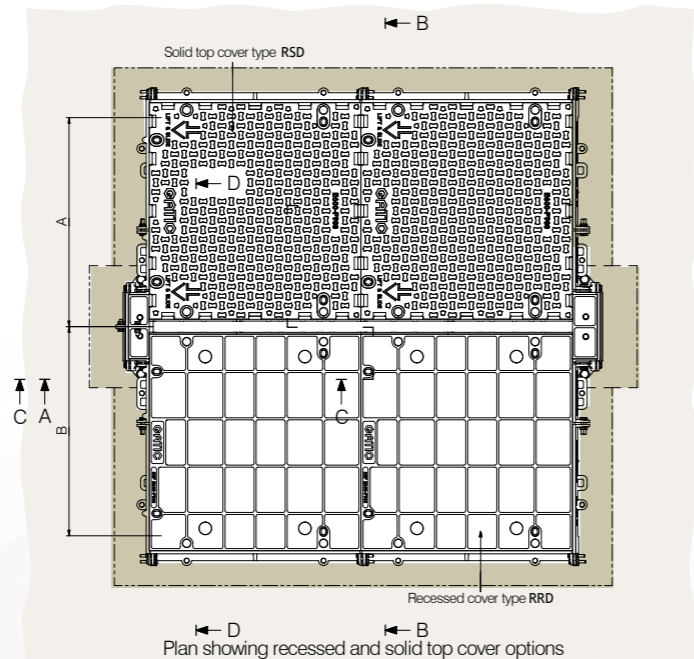

Plan showing recessed and solid top cover options

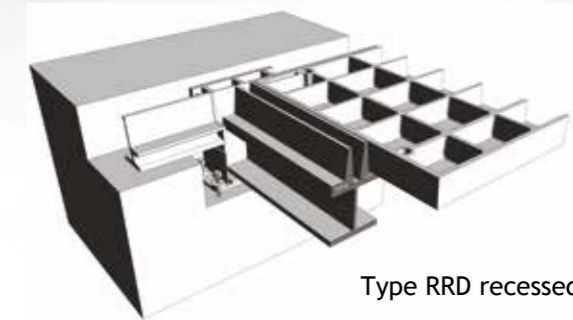

Type RRD recessed

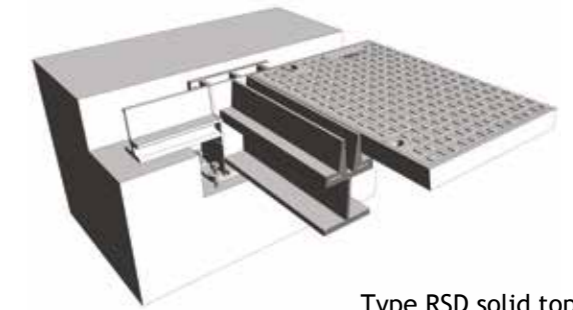

Type RSD solid top

Beam Size

The required beam size for Multispan covers is dependent on the pit clear opening length and the loading group.

The table shows maximum beam length against beam size. The removable support beams are supplied by Gatic.

The table also indicates dimensions of the beam wallbox and rebate to suit different beam sizes. See also the accompanying section details.

Support beam size chart

Removable support beam size	Max pit clear opening length (L)	Beam wallbox dimensions			
		V	W	X	Y
152 x 152 x 37 kg/m U.C	1750	264	286	330	230
203 x 203 x 52 kg/m U.C.	2300	308	330	370	230
305 x 165 x 54 kg/m U.B	2750	412	434	480	230
356 x 171 x 67 kg/m U.B	3150	465	487	535	300
457 x 152 x 82 kg/m U.B	3450	568	590	635	300
533 x 210 x 122 kg/m U.B	3900	647	669	715	300

Note: Removable support beams are supplied by Gatic

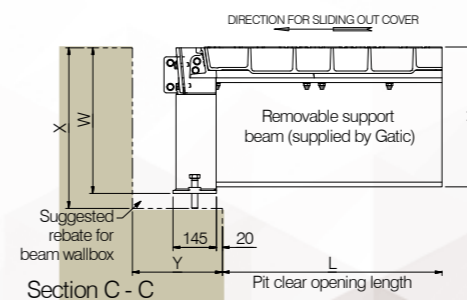

Section C - C

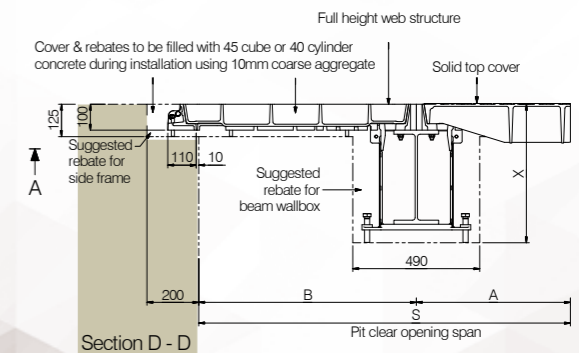

Section D - D

D400

Multispan covers and frames

Gatic Pave is a comprehensive system of single, duct and multi span access covers and frames for use in paved areas where an aesthetic finish is required in environments up to D400 loading.

Cover types

Covers are recessed for an aesthetic paviour infill.

Applications

Urban public places and parking areas.

Materials

The components of Pave covers are manufactured from: Ductile iron to BS EN 1563 and structural steel sections (removable beams) to BS EN 10365.

Non-rocking

Correctly installed, Pave covers will be non-rocking under slow moving traffic.

Gas Air & Water tight

A film of graphite grease between the contact faces of Gatic units provides a gas and airtight seal, and a watertight joint under normal rainwater conditions.

Secure and vandal resistant

Gatic covers cannot be removed without the correct lifting key so unauthorised removal is virtually impossible. Locking bolts can be fitted to Gatic cover keyways as an additional security feature. Gatic recommends that due to their weight with paviour infill, when Pave covers are removed they are lifted vertically using Gatic's mechanical lifting keys.

Closed keyways

Pave cover keyways are closed and fitted with plastic plugs to prevent the ingress of dirt.

Loadings

All Pave covers will withstand test load and maximum permanent set criteria specified in BS EN 124: up to D400.

Secure support

The clear opening width between supporting frames are at least 7mm greater than the pit/chamber design to allow for minor deviations in pit construction dimensions.

Beam wallbox

Supporting beams in Pave Multispan units are easily removed with appropriate lifting equipment for access to the total chamber area. Beam wallboxes do not project into the chamber opening.

Finishes:

Covers, removable supporting steelwork and side frames are supplied with a galvanised finish.

Installation:

Consignments of Pave units are accompanied by comprehensive installation instructions.

Environmental commitment:

Responsibility towards the environment is our primary concern. Our customers often now demand products that are made from recycled and recyclable materials, supplied by companies with robust environmental policies to reduce the environmental impact of their projects for future generations.

To meet these requirements we have an integrated Quality (BS EN ISO 9001) and Environmental (BS EN ISO 14001) Management System which encompasses the design, manufacture and management systems within the company and ensures our commitment to continuous environmental improvements regarding the manufacture and design of all our products in the following ways:

- **Minimise environmental impact**
- **Commit organisational resources to energy management**
- **Reduce energy costs**
- **Give high priority to energy efficient investments**
- **Consider life cycle energy costs for all new projects**
- **Minimise CO₂ emissions year on year**
- **Use energy from sustainable resources wherever possible**

To achieve these goals we have put in place the necessary systems and controls to meet demanding environmental targets and to make sure that these are maintained for the future benefit of the environment and our customers alike.

Gatic services:

Gatic offers a full support service to specifiers and contractors, including Computer Aided Design. AutoCAD compatible details of all Gatic products are available. Please consult our technical department for assistance.

In view of our commitment to product improvement, we reserve the right to alter designs without notice. Design changes will not adversely affect the performance or loading capability of our products.

Loading Group D400

POWER STATIONS, CARRIAGEWAYS, HARD SHOULDERS, AND PARKING AREAS FOR ALL TYPES OF VEHICLE

Suitable for 11.5 tonne slow moving pneumatic wheel load. Cover test load - 400kN

Pit clear opening size	Cover type	Overall Frame Size	Suggested rebate size
600 x 600	PAV	750 x 840 x 170	1000 x 1000 x 195
750 x 600	PAV	900 x 840 x 170	1150 x 1000 x 195
750 x 750	PAV	900 x 990 x 170	1150 x 1150 x 195

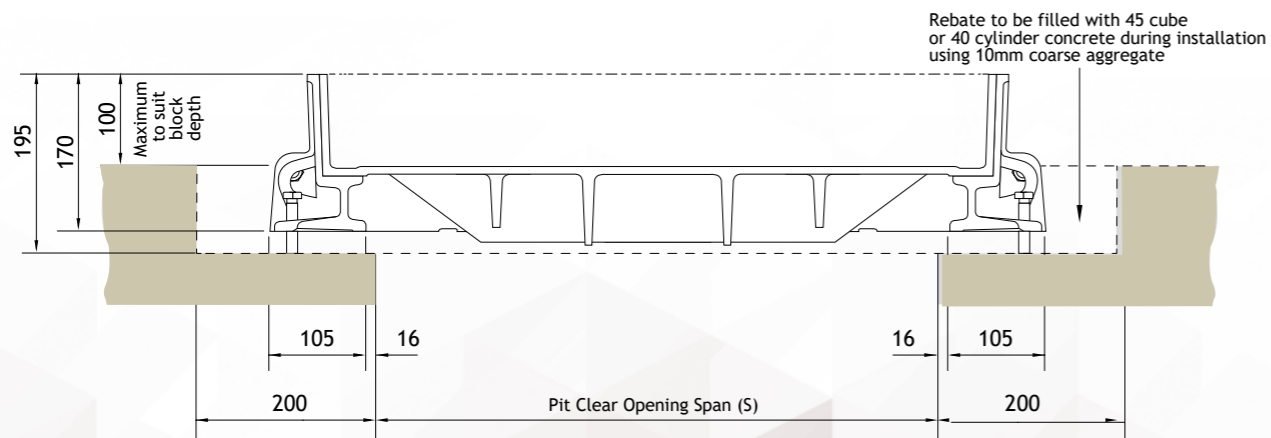

Suitable for 11.5 tonne slow moving pneumatic wheel load. Cover test load - 400kN

Pit clear opening size	Cover type	Suggested rebate size
600	PAV	(L + 400) x 1000 x 195
750	PAV	(L + 400) x 1150 x 195

Pave Covers

Pave covers can be supplied to cover ducts or trenches as straight runs.

Pit clear opening spans (mm)	Cover type	Standard Pit clear opening length									
		1300	1450	1600	2000	2150	2300	2450	2700	2850	3000
600	PAV	2	2	2	3	3	3	3	4	4	4
750	PAV	2	2	2	3	3	3	3	4	4	4

Pit clear opening spans (mm)	Cover type	Standard Pit clear opening length								
		3150	3300	3400	3550	3700	3850	4000	4100	4150
600	PAV	4	4	5	5	5	5	5	6	5
750	PAV	4	4	5	5	5	5	5	6	5

The number shown indicates the quantity of cover parts. Other cover sizes may be available. Please refer to our technical department.



Loading Group D400 POWER STATIONS, CARRIAGEWAYS, HARD SHOULDERS, AND PARKING AREAS FOR ALL TYPES OF VEHICLE

Suitable for 11.5 tonne slow moving pneumatic wheel load. Cover test load - 400kN

Specification

Below is a sample specification information and notes for Multispan recessed covers and frames.

For more details on features and benefits of Gatic covers, see pages 14 to 15.

Loading group Gatic D400

11.5 tonne wheel load - test load 400 kN.

Materials

Ductile iron components to BS EN 1563.

Structural steel removable beams to BS EN 10563.

Finishes

Units coated with black bituminous solution for protection during transit.

Removable supporting steelwork galvanised to BS EN ISO 1461.

Infill and surround concrete by customer

Concrete strength, using 10mm down coarse aggregate, to be: 45N/mm² for a test cube of 150mm or 40N/mm² for a test cylinder of 150mm diameter x 300mm high.

Installation

In accordance with instructions supplied by Gatic.

To specify use size and description format as follows:

Pave Multispan Recessed covers and frames Cover type **Pave recessed**

Multiple access covers recessed for concrete infill with removable beams.

.... in no. (length) x (span) mm pit clear opening multi span cover and frame.

Pave Type Ductile Iron Recessed Cover in parts complete with

.... in no. x mm galvanised removable support beam spanning the (length) mm way.

Suitable for Loading Group D400 - 11.5 Tonnes Wheel Load (pneumatic tyre).

Standard pit clear opening sizes are shown on page 65.

Beam sizes and other dimensions are shown on page 66 - 69.

For high density traffic conditions refer to page 14.

Refer to the table to identify which cover and beam configuration you require against pit clear opening length (L) and pit clear opening span (S). All dimensions are in millimetres.

	Pit clear opening span (S) mm	Pit clear opening length (L) mm									Beam centres (mm)							
		2 parts			3 parts				4 parts					A	B	C	D	E
		1300	1450	1600	2000	2150	2300	2450	2700	2850	2900	3000	3150	3300				
2 parts 1 beam	1380													690	690			
	1530													840	690			
	1680													840	840			
3 parts 2 beam	2160													690	780	690		
	2310													690	930	690		
	2460													840	780	840		
4 parts 3 beam	2610													840	930	840		
	2940													690	780	780	690	
	3090													840	780	780	690	
5 parts 4 beam	3240													840	780	780	840	
	3390													840	930	930	690	
	3540													840	930	930	840	
6 parts 5 beam	3720													690	780	780	780	690
	3870													690	780	930	780	690
	4020													840	780	780	780	840
7 parts 6 beam	4170													690	930	930	930	690
	4320													840	930	780	930	840
	4470													840	930	930	930	840
8 parts 7 beam	4620													690	780	780	780	690
	4770													690	780	930	780	690
	4920													840	780	780	780	840
9 parts 8 beam	5070													690	930	930	930	690
	5220													840	930	780	930	840
	5370													840	930	930	930	840
10 parts 9 beam	5520													690	780	780	780	690
	5670													690	780	930	780	690
	5820													840	780	780	780	840
11 parts 10 beam	5970													690	930	930	930	690
	6120													840	930	780	930	840
	6270													840	930	930	930	840
12 parts 11 beam	6420													690	780	780	780	690
	6570													690	780	930	780	690
	6720													840	780	780	780	840
13 parts 12 beam	6870													690	930	930	930	690
	7020													840	930	780	930	840
	7170													840	930	930	930	840
14 parts 13 beam	7320													690	780	780	780	690
	7470													690	780	930	780	690
	7620													840	780	780	780	840
15 parts 14 beam	7770													690	930	930	930	690
	7920													840	930	780	930	840
	8070													840	930	930	930	840
16 parts 15 beam	8220													690	780	780	780	690
	8370													690	780	930	780	690
	8520													840	780	780	780	840
17 parts 16 beam	8670													690	930	930	930	690
	8820													840	930	780	930	840
	8970													840	930	930	930	840
18 parts 17 beam	9120													690	780	780	780	690
	9270													690	780	930	780	690
	9420													840	780	780	780	840
19 parts 18 beam	9570													690	930	930	930	690
	9720													840	930	780	930	840
	9870													840	930	930	930	840
20 parts 19 beam	10020													690	780	780	780	690
	10170													690	780	930	780	690
	10320													840	780	780	780	840

Loading Group D400

POWER STATIONS, CARRIAGEWAYS, HARD SHOULDERS, AND PARKING AREAS FOR ALL TYPES OF VEHICLE

Suitable for 11.5 tonne slow moving pneumatic wheel load. Cover test load - 400kN

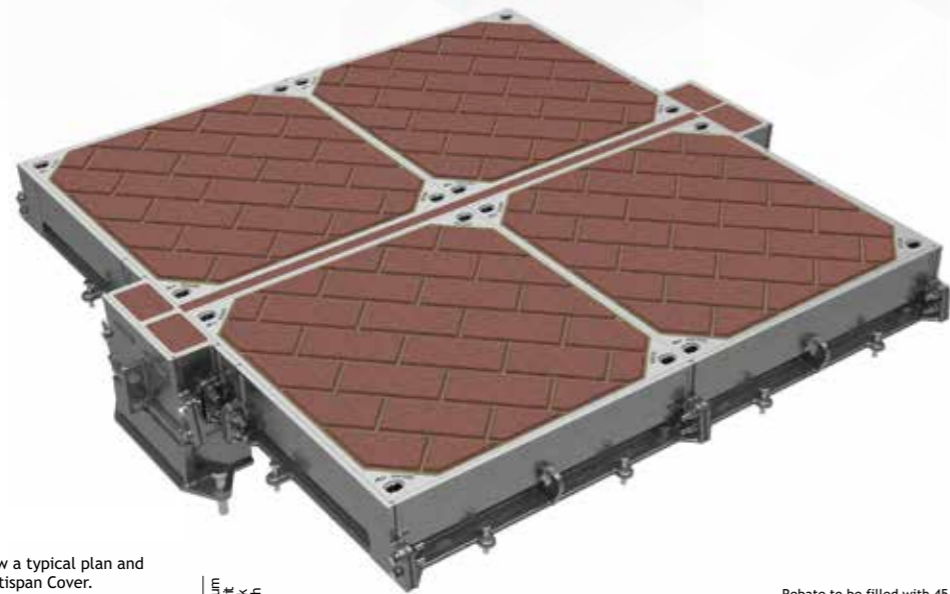

The details below show a typical plan and sections of a Pave Multispan Cover.

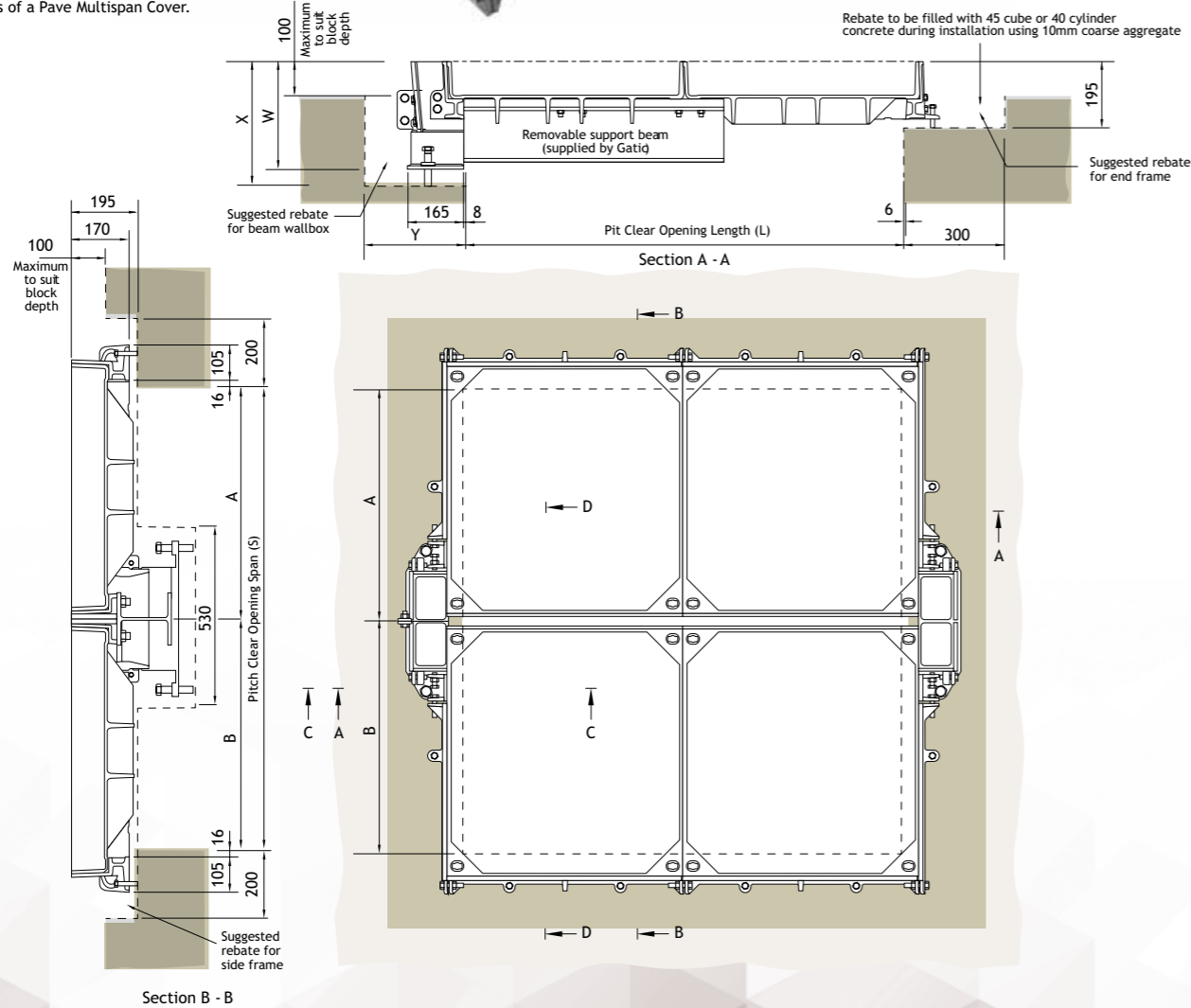

Beam Size

The required beam size for Multispan covers is dependent on the pit clear opening length and the loading group.

The table shows maximum beam length against beam size. The removable support beams are supplied by Gatic.

The table also indicates dimensions of the beam wallbox and rebate to suit different beam sizes. See also the accompanying section details.

Support beam size chart

Removable support beam size	Max pit clear opening length (L)	Beam wallbox dimensions			
		V	W	X	Y
152 x 152 x 37 kg/m U.C	1750	297	319	365	230
203 x 203 x 52 kg/m U.C.	2300	341	363	405	230
305 x 165 x 54 kg/m U.B	2750	445	467	515	230
356 x 171 x 67 kg/m U.B	3150	498	520	570	300
457 x 152 x 82 kg/m U.B	3450	601	623	670	300
533 x 210 x 122 kg/m U.B	3900	680	702	750	300

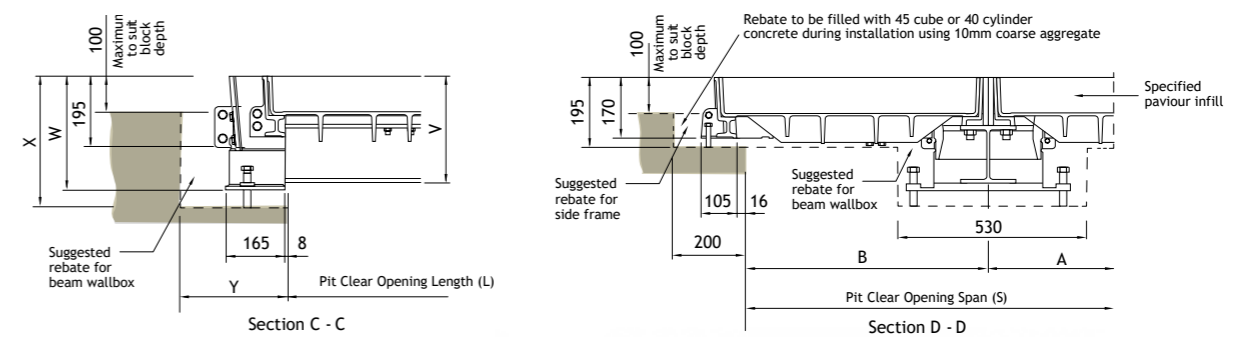

Loading Group D400

POWER STATIONS, CARRIAGEWAYS, HARD SHOULDERS,
AND PARKING AREAS FOR ALL TYPES OF VEHICLE

PAVE D400

Gatic recommends that due to their weight with paviour infill, when Pave covers are removed they are lifted using Gatic's Mechanical lifting keys.

A Mechanical lifting key is inserted into each of the four keyways found on all Gatic Pave covers which are designed and tested for use with cranes and other mechanical devices

Full operating and installation instructions are available from Gatic.

Lifting Keys

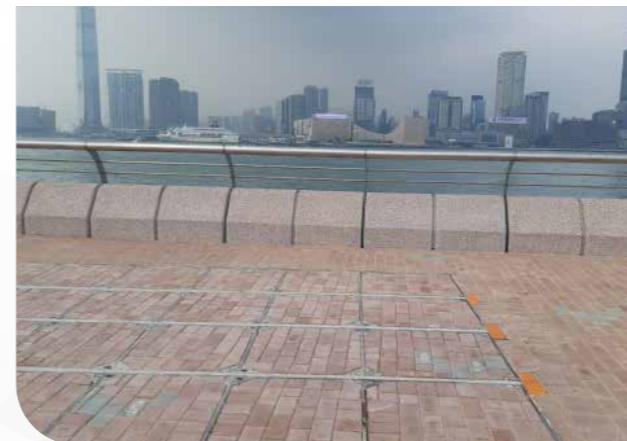
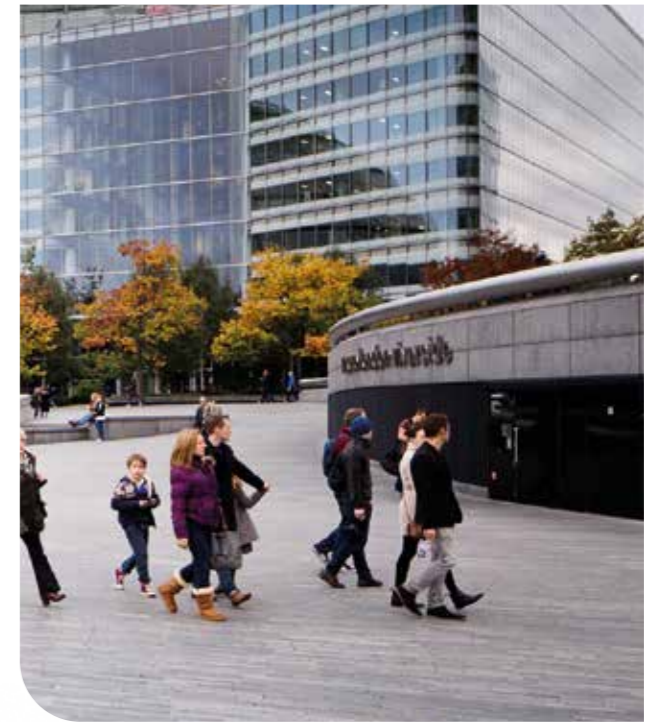
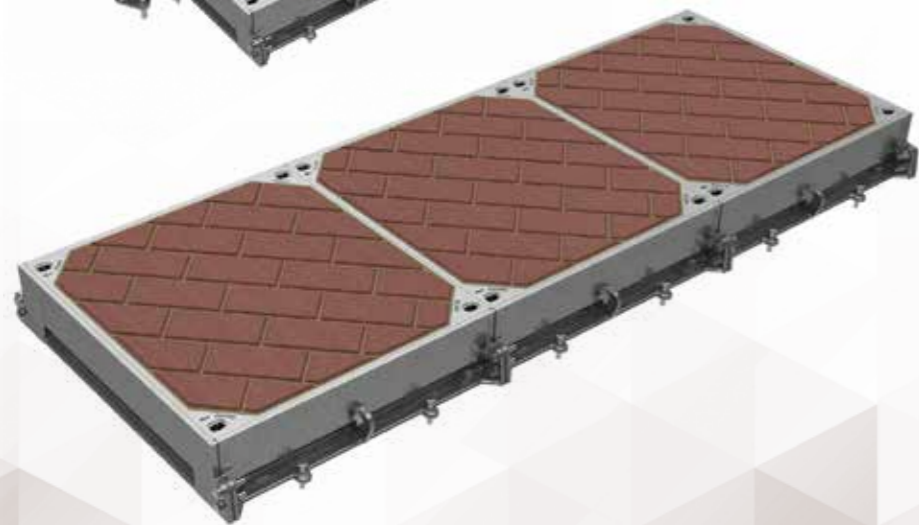
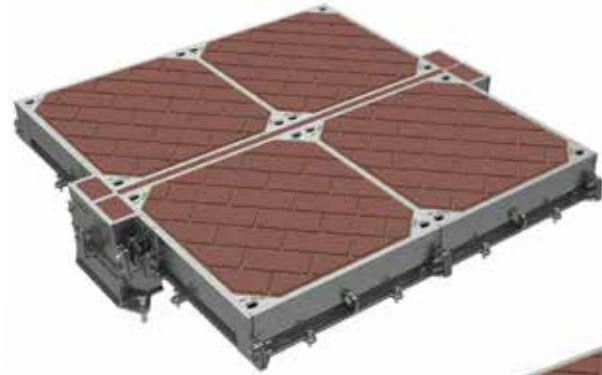
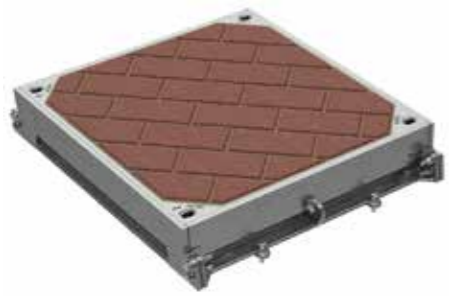

D400 PAVE

Loading Group C250

FOR ROADS CARRYING RELATIVELY SLOW-MOVING TRAFFIC EG, MINOR RESIDENTIAL ROADS, CUL-DE-SACS, PEDESTRIAN PRECINCTS, YARDS, ETC

Introduction

This section includes Gatic covers and frames designed for Loading Group C250.

5 tonne wheel load, test load 250kN - Suitable for:

- Minor residential roads
- Cul-de-sacs
- Pedestrian precincts
- Yards, etc



C250 assemblies are available with a choice of cover designs - recessed or solid top.

Recessed for concrete infill: Recessed covers are available in a choice of designs designated by a 'Type' reference. C250 recessed covers are available as Type DLF, DM, DM/F and DMR. Section drawings of the different recessed cover types are shown on the following pages.



Solid top: Solid top cover types are lighter in weight than recessed covers, and feature an anti-slip surface. Solid top covers are denoted by the code Type DLS and RSD depicted in section on the following pages.

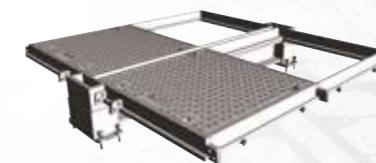

If you are uncertain as to the adequacy of covers conforming to a particular loading, we recommend specifying covers in a higher loading group. For example, if in doubt about covers in Loading Group C250, we recommend you specify covers in Loading Group D400.

C250

Cover Types

Single covers and frames



Duct covers and frames



Continuous trench covers and frames



Multispan covers and frames



Loading Group C250

FOR ROADS CARRYING RELATIVELY SLOW-MOVING TRAFFIC EG, MINOR RESIDENTIAL ROADS, CUL-DE-SACS, PEDESTRIAN PRECINCTS, YARDS, ETC

C250



- Covers recessed for concrete infill
- Cover types: DLF, DMR, DM
 - To specify state:
 - Loading group
 - Pit clear opening size length (L) x span (S)
 - Cover type

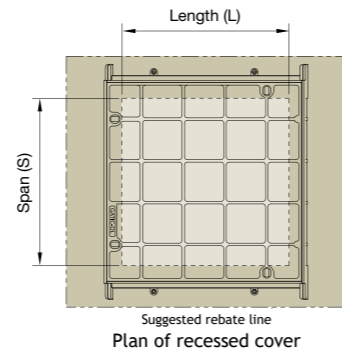

Pit clear opening sizes L x S	Cover type	Overall frame size length x width x depth	Suggested rebate size length x width x depth
750 x 300	DLF	900 x 540 x 75	1050 x 600 x 100
600 x 450	DLF	750 x 690 x 75	900 x 750 x 100
750 x 450	DMR	900 x 670 x 140	1150 x 850 x 165
600 x 600	DLF	770 x 840 x 75	900 x 900 x 100
750 x 600	DLF	920 x 840 x 75	1050 x 900 x 100
900 x 600	DLF	1070 x 840 x 75	1200 x 900 x 100
750 x 750	DLF	920 x 990 x 75	1050 x 1050 x 100
900 x 750	DLF	1070 x 990 x 75	1200 x 1050 x 100
900 x 900	DLF	1120 x 1140 x 75	1200 x 1200 x 100
600 x 1050	DM	820 x 1270 x 140	1000 x 1450 x 165
750 x 1050	DM	970 x 1270 x 140	1150 x 1450 x 165
1000 x 1050	DM	1220 x 1270 x 140	1400 x 1450 x 165
600 x 1200	DM	820 x 1420 x 140	1000 x 1600 x 165
750 x 1200	DM	970 x 1420 x 140	1150 x 1600 x 165
600 x 1500	DM/F	820 x 1720 x 140	1000 x 1900 x 165
750 x 1500	DM/F	970 x 1720 x 140	1150 x 1900 x 165



- Covers with solid top
- Cover types: DLS, RSD
 - To specify state:
 - Loading group
 - Pit clear opening size length (L) x span (S)
 - Cover type

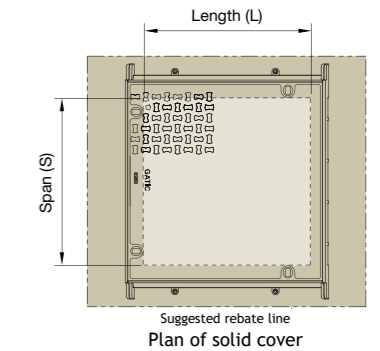

Pit clear opening sizes L x S	Cover type	Overall frame size length x width x depth	Suggested rebate size length x width x depth
600 x 600	DLS	770 x 840 x 75	900 x 900 x 100
750 x 600	DLS	920 x 840 x 75	1050 x 900 x 100
900 x 600	DLS	1070 x 840 x 75	1200 x 900 x 100
750 x 750	DLS	920 x 990 x 75	1050 x 1050 x 100
900 x 750	DLS	1070 x 990 x 75	1200 x 1050 x 100
900 x 900	DLS	1120 x 1040 x 75	1200 x 1200 x 100
600 x 1200	RSD	750 x 1420 x 100	1000 x 1600 x 125
750 x 1200	RSD	900 x 1420 x 100	1150 x 1600 x 125
1000 x 1000	RSD	1220 x 1240 x 100	1400 x 1400 x 125

C250

Single solid top covers and frames

Single recessed covers and frames

Cover types

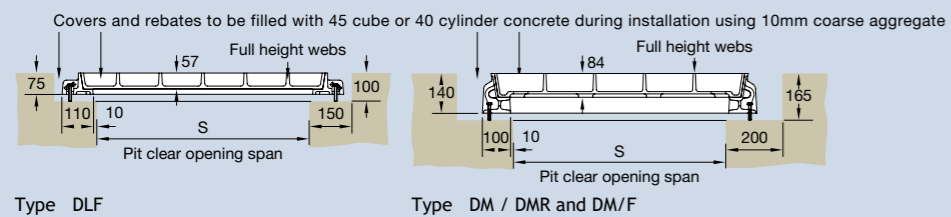

Cover types

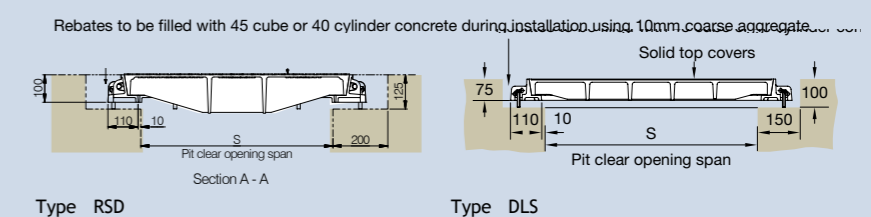

Loading Group C250

FOR ROADS CARRYING RELATIVELY SLOW-MOVING TRAFFIC EG, MINOR RESIDENTIAL ROADS, CUL-DE-SACS, PEDESTRIAN PRECINCTS, YARDS, ETC



- Covers recessed for concrete infill
 - Cover types: DLF, DM, DMF, DM/F
- To specify state:
- Loading group
 - Pit clear opening size length (L) x span (S)
 - Cover type

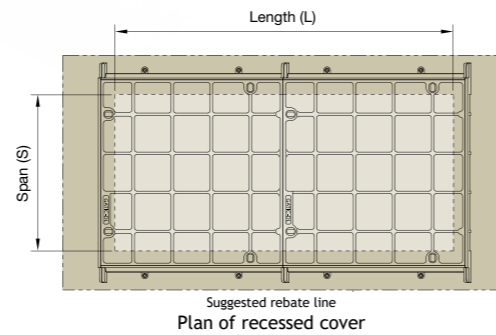

Pit clear opening sizes	Cover type	Suggested rebate size length x width x depth
300	DLF	(L + 300) x 600 x 100
450	DLF	(L + 300) x 750 x 100
600	DLF	(L + 300) x 900 x 100
750	DLF	(L + 300) x 1050 x 100
900	DLF	(L + 300) x 1200 x 100
1050	DM	(L + 400) x 1450 x 165
1200	DM	(L + 400) x 1600 x 165
1500	DM/F	(L + 400) x 1900 x 165

Pit clear opening span (S)	Cover type	Standard pit clear opening length (L)											
		1300	1450	1600	1750	1900	2000	2150	2300	2450	2600	2700	2750
300	DLF	*	*	2	*	*	*	*	*	3	*	*	*
450	DLF	2	*	*	*	*	3	*	*	*	*	4	*
600	DLF	2	2	2	2	2	3	3	3	3	3	4	3
750	DLF	2	2	2	2	2	3	3	3	3	3	4	3
900	DLF	2	2	2	2	2	3	3	3	3	3	4	3
1050	DM	2	2	2	*	*	3	3	3	3	*	4	*
1200	DM	2	2	2	*	*	3	3	3	3	*	4	*
1500	DM/F	2	2	2	*	*	3	3	3	3	*	4	*

Pit clear opening span (S)	Cover type	Standard pit clear opening length (L)											
		2850	2900	3000	3150	3300	3400	3550	3700	3850	3900	4000	4150
300	DLF	*	*	*	*	4	*	*	*	*	*	*	5
450	DLF	*	*	*	*	*	5	*	*	*	*	*	*
600	DLF	4	3	4	4	4	5	5	5	5	4	5	5
750	DLF	4	3	4	4	4	5	5	5	5	4	5	5
900	DLF	4	3	4	4	4	5	5	5	5	4	5	5
1050	DM	4	*	4	4	4	5	5	5	5	*	5	5
1200	DM	4	*	4	4	4	5	5	5	5	*	5	5
1500	DM/F	4	*	4	4	4	5	5	5	5	*	5	5

Cover types

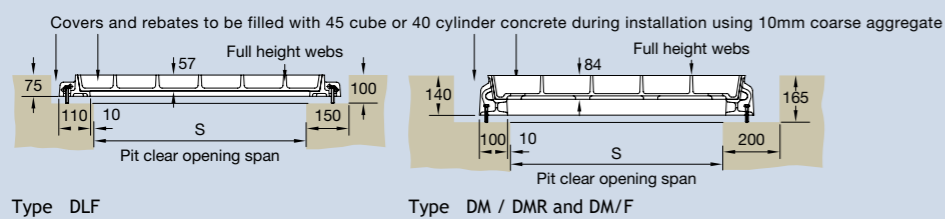

* Indicates standard sizes not available. The number shown indicates the quantity of cover parts. Other standard sizes may be available, refer to our technical department.



- Covers with solid top
 - Cover types: DLS, RSD
- To specify state:
- Loading group
 - Pit clear opening size length (L) x span (S)
 - Cover type

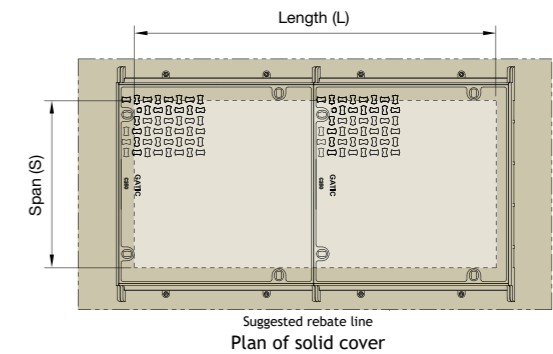

Pit clear opening sizes	Cover type	Suggested rebate size length x width x depth
600	DLS	(L + 300) x 900 x 100
750	DLS	(L + 300) x 1050 x 100
900	DLS	(L + 300) x 1200 x 100
1200	RSD	(L + 400) x 1600 x 125

Pit clear opening span (S)	Cover type	Standard pit clear opening length (L)											
		1300	1450	1600	1750	1900	2000	2150	2300	2450	2600	2700	2750
600	DLS	2	2	2	2	2	3	3	3	3	3	4	3
750	DLS	2	2	2	2	2	3	3	3	3	3	4	3
900	DLS	2	2	2	2	2	3	3	3	3	3	4	3
1200	RSD	2	2	2	*	*	3	3	3	3	*	4	*

Pit clear opening span (S)	Cover type	Standard pit clear opening length (L)											
		2850	2900	3000	3150	3300	3400	3550	3700	3850	3900	4000	4150
600	DLS	4	3	4	4	4	5	5	5	5	4	5	5
750	DLS	4	3	4	4	4	5	5	5	5	4	5	5
900	DLS	4	3	4	4	4	5	5	5	5	4	5	5
1200	RSD	4	*	4	4	4	5	5	5	5	*	5	5

* Indicates standard sizes not available. The number shown indicates the quantity of cover parts. Other standard sizes may be available, refer to our technical department.

Cover types

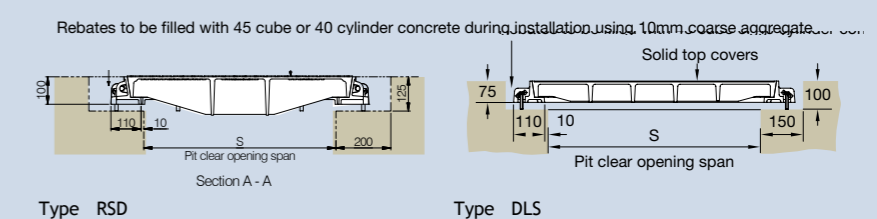

Loading Group C250

FOR ROADS CARRYING RELATIVELY SLOW-MOVING TRAFFIC EG, MINOR RESIDENTIAL ROADS, CUL-DE-SACS, PEDESTRIAN PRECINCTS, YARDS, ETC



- Covers recessed for concrete infill
 - Cover type DLF, DM, DM/F
- To specify state:
- Loading group
 - Cover type
 - Supply layout drawing of trenches

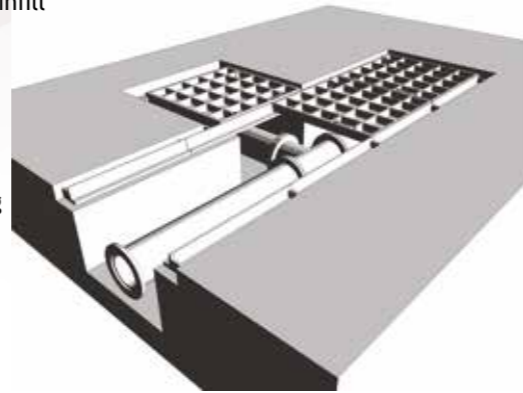

Continuous recessed cover

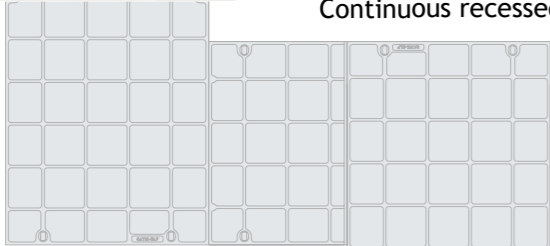

Pit clear opening span	Cover type
300	DLF
450	DLF
600	DLF
750	DLF
900	DLF
1050	DM
1200	DM
1500	DM/F

Note: type DM/F refer to our technical department

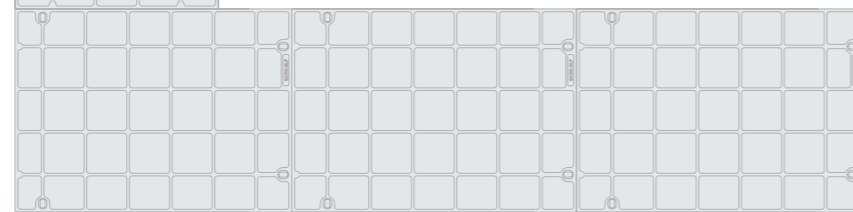
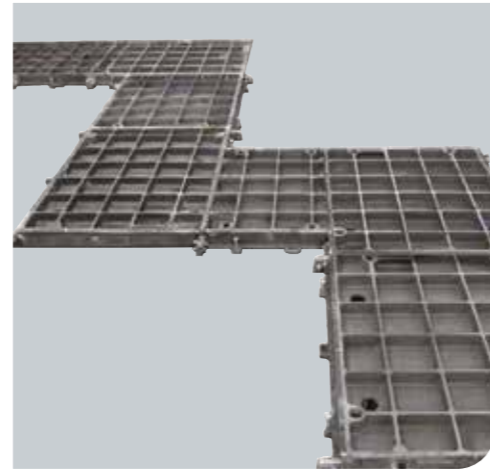

Gatic covers can be formed to make continuous trenches or layouts providing total access to services below.

Construction drawings are required so that Gatic cover layout drawings can be prepared.

Cover types

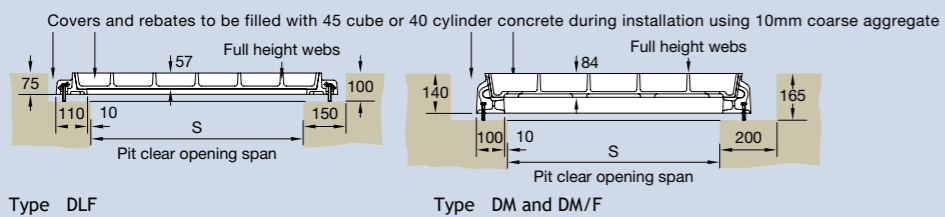

- Covers with solid top
 - Cover type DLS, RSD
- To specify state:
- Loading group
 - Cover type
 - Supply layout drawing of trenches

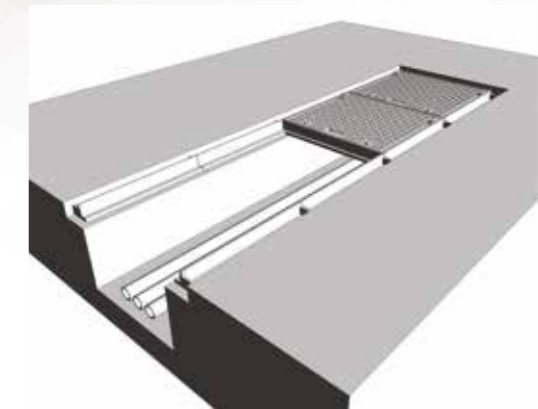

Continuous solid top cover

Pit clear opening span	Cover type
600	DLS
750	DLS
900	DLS
1200	RSD

Standard solid top covers are supplied in straight runs. Junctions and splays can be achieved by the inclusion of localised recessed covers. Refer to our technical department for more information.

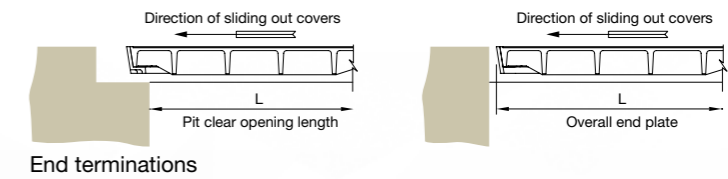

Cover types

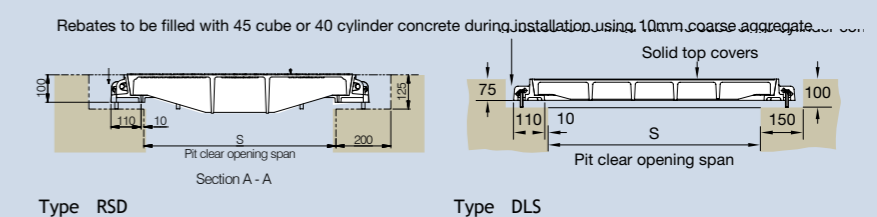

Loading Group C250

FOR ROADS CARRYING RELATIVELY SLOW-MOVING TRAFFIC EG, MINOR RESIDENTIAL ROADS, CUL-DE-SACS, PEDESTRIAN PRECINCTS, YARDS, ETC

Specification

Below is a sample specification information and notes for Multispan recessed covers and frames.

For more details on features and benefits of Gatic covers, see pages 14 to 15.

Loading group Gatic C250

5 tonne wheel load - test load 250 kN.

Materials

Ductile iron components to BS EN 1563.

Structural steel removable beams to BS EN 10365.

Finishes

Units coated with black bituminous solution for protection during transit.

Removable supporting steelwork galvanised to BS EN ISO 1461.

Infill and surround concrete by customer

Concrete strength, using 10mm down coarse aggregate, to be: 45N/mm² for a test cube of 150mm or 40N/mm² for a test cylinder of 150mm diameter x 300mm high.

Installation

In accordance with instructions supplied by Gatic.

To specify use size and description format as follows:

Gatic Multispan Recessed covers and frames Cover type DLF recessed

Multiple access covers recessed for concrete infill with removable beams.

.... in no. (length) x (span) mm pit clear opening multi span cover and frame. Gatic Type DLF Ductile Iron Recessed Cover in parts complete with in no. x mm galvanised removable support beam spanning the (length) mm way.

Suitable for Loading Group C250 - Medium Duty 5 Tonnes Wheel Load (pneumatic tyre).

Gatic Multispan Solid Top covers and frames Cover type DLS solid top

Multiple solid top access covers with removable beams.

.... in no. (length) x (span) mm pit clear opening multi span cover and frame. Gatic Type DLS Ductile Iron Solid Top Cover in parts complete with in no. x mm galvanised removable support beam spanning the (length) mm way.

Suitable for Loading Group C250 - Medium Duty 5 Tonnes Wheel Load (pneumatic tyre).

Standard pit clear opening sizes are shown on page 79.

Beam sizes and other dimensions are shown on page 80 - 81

For high density traffic conditions refer to page 14.



Type DLF recessed



Type DLS solid top

Product Selection

Refer to the table to identify which cover and beam configuration you require against pit clear opening length (L) and pit clear opening span (S). All dimensions are in millimetres.

Pit clear opening span (S) mm		Pit clear opening length (L) mm									Beam centres mm									
		2 parts			3 parts			4 parts			A	B	C	D	E					
		1300	1450	1600	1750	1900	2000	2150	2300	2450	2600	2750	2900	2700	2850	3000	3150	3300	3450	3600
1 beam	1380	[Diagram]			[Diagram]			[Diagram]			690	690								
	1530	[Diagram]			[Diagram]			[Diagram]			840	690								
	1680	[Diagram]			[Diagram]			[Diagram]			840	840								
	1830	[Diagram]			[Diagram]			[Diagram]			990	840								
	1980	[Diagram]			[Diagram]			[Diagram]			990	990								
2 beams	2160	[Diagram]			[Diagram]			[Diagram]			690	780	690							
	2310	[Diagram]			[Diagram]			[Diagram]			690	930	690							
	2460	[Diagram]			[Diagram]			[Diagram]			840	780	840							
	2610	[Diagram]			[Diagram]			[Diagram]			840	930	840							
	2760	[Diagram]			[Diagram]			[Diagram]			840	1080	840							
3 beams	2910	[Diagram]			[Diagram]			[Diagram]			990	930	990							
	3060	[Diagram]			[Diagram]			[Diagram]			990	1080	990							
	3210	[Diagram]			[Diagram]			[Diagram]			690	780	780	690						
	3360	[Diagram]			[Diagram]			[Diagram]			840	780	780	840						
	3510	[Diagram]			[Diagram]			[Diagram]			840	930	930	840						
4 beams	3660	[Diagram]			[Diagram]			[Diagram]			840	930	930	840						
	3810	[Diagram]			[Diagram]			[Diagram]			990	930	930	990						
	3960	[Diagram]			[Diagram]			[Diagram]			990	930	930	990						
	4110	[Diagram]			[Diagram]			[Diagram]			990	1080	1080	840						
	4260	[Diagram]			[Diagram]			[Diagram]			990	1080	1080	990						
5 beams	4410	[Diagram]			[Diagram]			[Diagram]			690	780	780	780	690					
	4560	[Diagram]			[Diagram]			[Diagram]			690	780	930	780	690					
	4710	[Diagram]			[Diagram]			[Diagram]			840	780	780	780	840					
	4860	[Diagram]			[Diagram]			[Diagram]			690	930	930	930	690					
	5010	[Diagram]			[Diagram]			[Diagram]			840	930	780	930	840					
	5160	[Diagram]			[Diagram]			[Diagram]			840	930	930	930	840					
	5310	[Diagram]			[Diagram]			[Diagram]			840	930	930	930	840					
	5460	[Diagram]			[Diagram]			[Diagram]			840	930	1080	930	840					
	5610	[Diagram]			[Diagram]			[Diagram]			990	930	930	930	990					
	5760	[Diagram]			[Diagram]			[Diagram]			990	930	1080	930	990					
5910	[Diagram]			[Diagram]			[Diagram]			990	1080	930	1080	990						
6060	[Diagram]			[Diagram]			[Diagram]			990	1080	1080	1080	990						

Loading Group C250

FOR ROADS CARRYING RELATIVELY SLOW-MOVING TRAFFIC EG, MINOR RESIDENTIAL ROADS, CUL-DE-SACS, PEDESTRIAN PRECINCTS, YARDS, ETC

C250

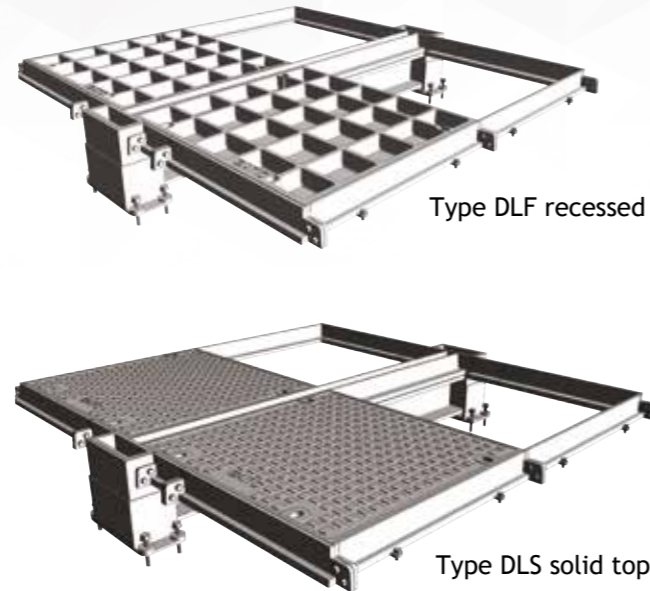

- Covers recessed for concrete infill or solid top
- Cover types: DLF` (recessed) DLS (solid top)

The details below show plan and sections of a typical recessed/solid top unit. For selection and specification guidance, refer to page 78.

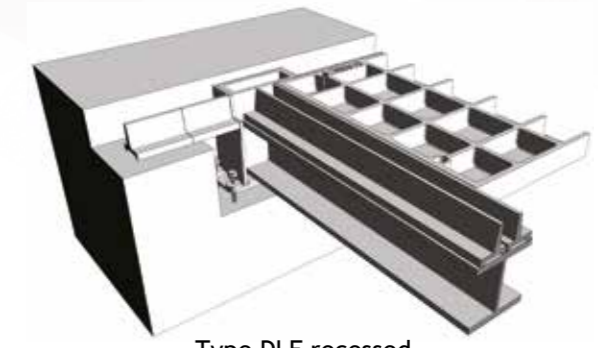
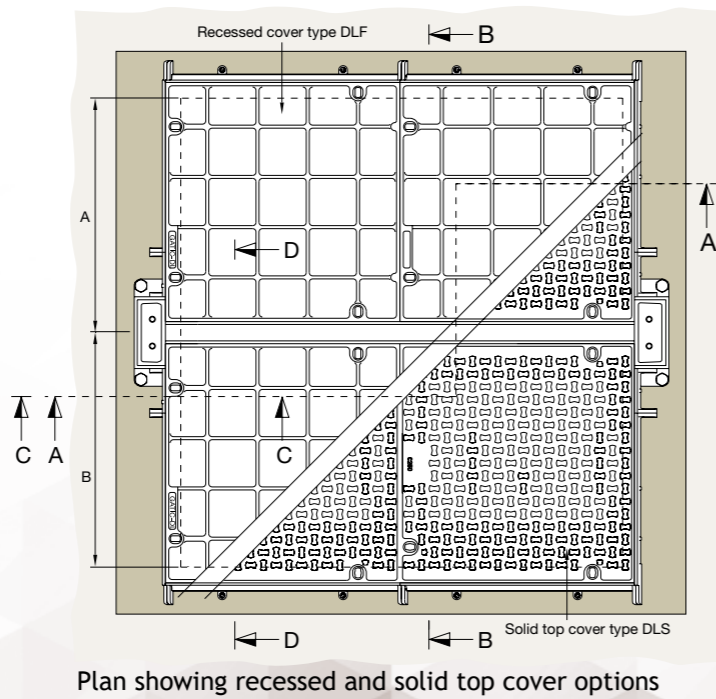
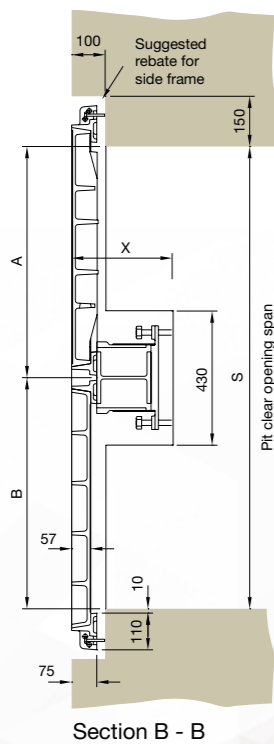
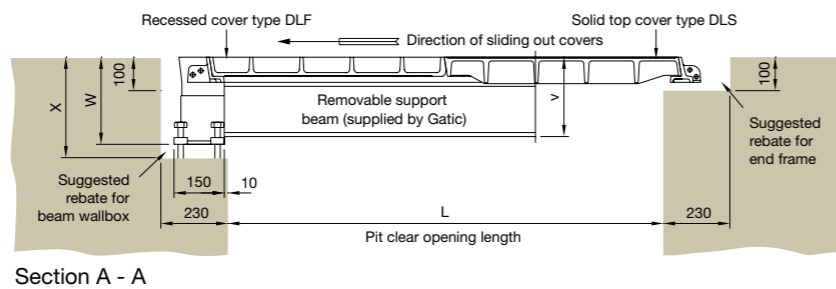

Type DLF recessed

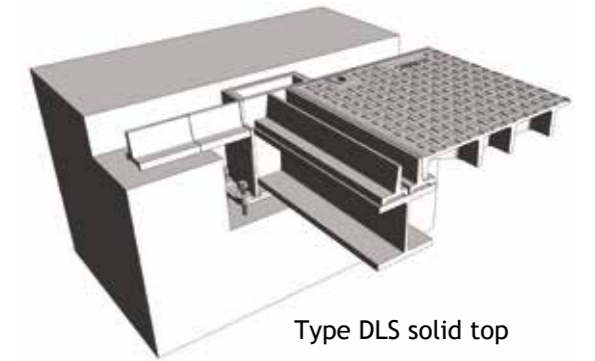

Type DLS solid top

Beam Size

The required beam size for Multispan covers is dependent on the pit clear opening length and the loading group. The table shows maximum beam length against beam size. The removable support beams are supplied by Gatic. The table also indicates dimensions of the beam wallbox and rebate to suit different beam sizes. See also the accompanying section details.

Support beam size chart

Removable support beam size	Max pit clear opening length (L)	Beam wallbox dimensions			
		V	W	X	Y
152 x 152 x 37 kg/m U.C	2450	237	259	300	230
203 x 203 x 52 kg/m U.C.	3150	281	303	345	230
305 x 165 x 54 kg/m U.B	3750	385	407	450	230
356 x 171 x 67 kg/m U.B	3900	438	460	505	230

Note: Removable support beams are supplied by Gatic

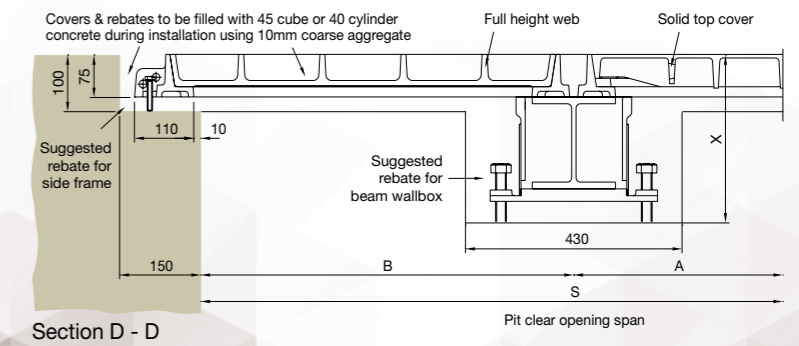
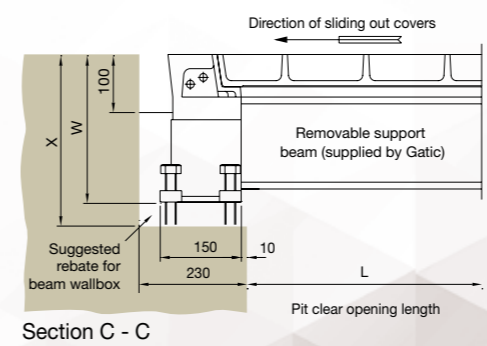

C250

Multispan Covers & Frames

Multispan Covers & Frames

Loading Group B125

FOOTWAYS, PEDESTRIAN AREAS, CAR PARKS,
DRIVEWAYS AND INTERNAL FLOORS

Introduction

This section includes Gatic covers and frames designed for Loading Group B125.

3 tonne wheel load, test load 125kN - Suitable for:

- Footways
- Pedestrian areas
- Car parks
- Driveways
- Internal floors

B125 assemblies are available with a choice of cover designs - recessed or solid top.

Recessed for concrete infill

Recessed covers are available in a choice of designs designated by a 'Type' reference. B125 recessed covers are available as Type DL, DLF and DM/F. Section drawings of the different recessed cover types are shown on the following pages.



Solid top

Solid top cover types are lighter in weight than recessed covers, and feature an anti-slip surface. Solid top covers are denoted by the code Type DLS and RSD depicted in section on the following pages.



If you are uncertain as to the adequacy of covers conforming to a particular loading, we recommend specifying covers in a higher loading group. For example, if in doubt about covers in Loading Group B125, we recommend you specify covers in Loading Group C250.

Single covers and frames



Duct covers and frames



Continuous trench covers & frames



Multispan covers and frames



B125

Range

Loading Group B125

FOOTWAYS, PEDESTRIAN AREAS, CAR PARKS, DRIVEWAYS AND INTERNAL FLOORS

B125



- Covers recessed for concrete infill
- Cover types: DLF, DL, DM, DM/F

To specify state:

1. Loading group
2. Pit clear opening size length (L) x span (S)
3. Cover type



Pit clear opening sizes	Cover type	Overall frame size length x width x depth	Suggested rebate size length x width x depth
750 x 300	DLF	900 x 540 x 75	1050 x 600 x 100
600 x 450	DL	750 x 690 x 75	900 x 750 x 100
750 x 450	DL	900 x 690 x 75	1050 x 750 x 100
600 x 600	DL	770 x 840 x 75	900 x 900 x 100
750 x 600	DL	920 x 840 x 75	1050 x 900 x 100
900 x 600	DL	1070 x 840 x 75	1200 x 900 x 100
750 x 750	DL	920 x 990 x 75	1050 x 1050 x 100
900 x 750	DL	1070 x 990 x 75	1200 x 1050 x 100
900 x 900	DL	1120 x 1140 x 75	1200 x 1200 x 100
600 x 1050	DL	850 x 1290 x 75	900 x 1350 x 100
750 x 1050	DL	1000 x 1290 x 75	1050 x 1350 x 100
1000 x 1050	DM	1220 x 1270 x 140	1400 x 1450 x 165
600 x 1200	DM	820 x 1420 x 140	1000 x 1600 x 165
750 x 1200	DM	970 x 1420 x 140	1150 x 1600 x 165
600 x 1500	DM/F	820 x 1720 x 140	1000 x 1900 x 165
750 x 1500	DM/F	970 x 1720 x 140	1150 x 1900 x 165

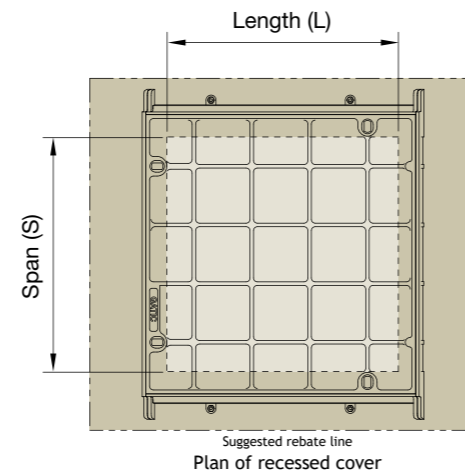

- Covers with solid top
- Cover types: DLS, RSD

To specify state:

1. Loading group
2. Pit clear opening size length (L) x span (S)
3. Cover type



Pit clear opening sizes	Cover type	Overall frame size length x width x depth	Suggested rebate size length x width x depth
600 x 600	DLS	770 x 840 x 75	900 x 900 x 100
750 x 600	DLS	920 x 840 x 75	1050 x 900 x 100
900 x 600	DLS	1 070 x 840 x 75	1200 x 900 x 100
750 x 750	DLS	920 x 990 x 75	1050 x 1050 x 100
900 x 750	DLS	1070 x 990 x 75	1200 x 1050 x 100
900 x 900	DLS	1120 x 1140 x 75	1200 x 1200 x 100
600 x 1200	RSD	750 x 1420 x 100	1000 x 1600 x 125
750 x 1200	RSD	900 x 1420 x 100	1150 x 1600 x 125
1000 x 1000	RSD	1220 x 1240 x 100	1400 x 1400 x 125

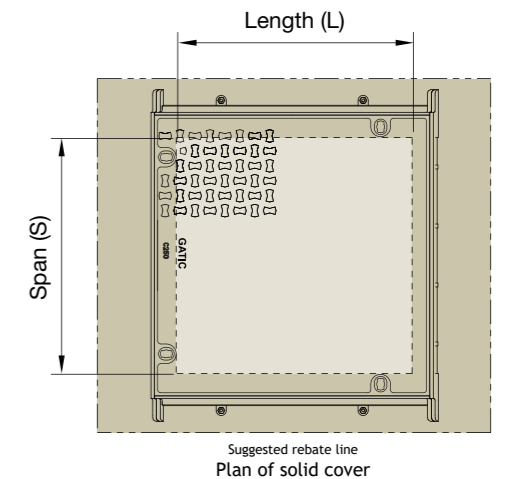

Single recessed covers and frames

B125

Single solid top covers and frames

Cover types

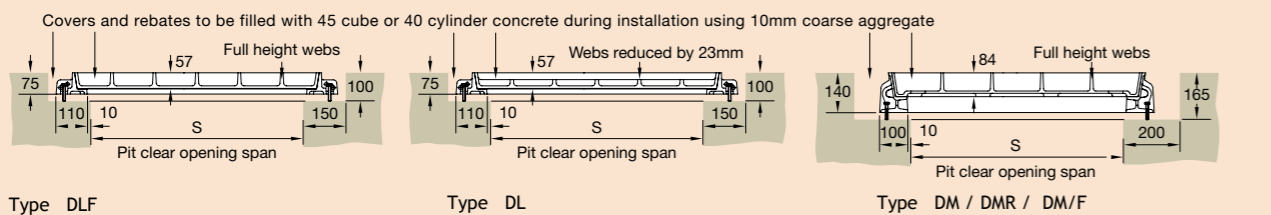

Cover types

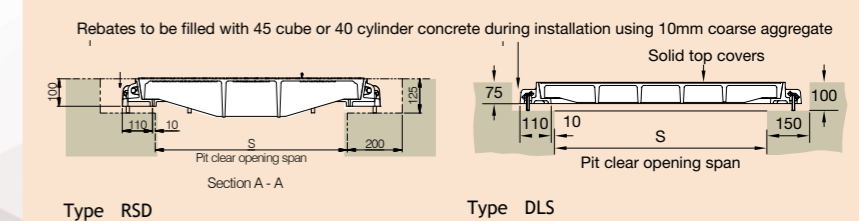

Loading Group B125

FOOTWAYS, PEDESTRIAN AREAS, CAR PARKS, DRIVEWAYS AND INTERNAL FLOORS

B125

Recessed duct covers and frames



- Covers recessed for concrete infill
- Cover types: DLF, DL, DM, DM/F

To specify state:

- Loading group
- Pit clear opening size length (L) x span (S)
- Cover type

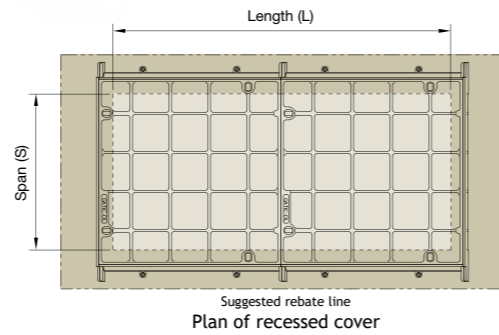

Pit clear opening sizes	Cover type	Suggested rebate size length x width x depth
300	DLF	(L + 300) x 600 x 100
450	DL	(L + 300) x 750 x 100
600	DL	(L + 300) x 900 x 100
750	DL	(L + 300) x 1050 x 100
900	DL	(L + 300) x 1200 x 100
1050	DL	(L + 300) x 1350 x 100
1200	DM	(L + 400) x 1600 x 165
1500	DM/F	(L + 400) x 1900 x 165

Pit clear opening span (S)	Cover type	Standard pit clear opening length (L)											
		1300	1450	1600	1750	1900	2000	2150	2300	2450	2600	2700	2750
300	DLF	*	*	2	*	*	*	*	*	3	*	*	*
450	DL	2	2	2	2	*	3	3	3	3	*	4	*
600	DL	2	2	2	2	2	3	3	3	3	3	4	3
750	DL	2	2	2	2	2	3	3	3	3	3	4	3
900	DL	2	2	2	2	2	3	3	3	3	3	4	3
1050	DL	2	2	2	*	*	3	3	3	3	*	4	*
1200	DM	2	2	2	*	*	3	3	3	3	*	4	*
1500	DM/F	2	2	2	*	*	3	3	3	3	*	4	*

Pit clear opening span (S)	Cover type	Standard pit clear opening length (L)											
		2850	2900	3000	3150	3300	3400	3550	3700	3850	3900	4000	4150
300	DLF	*	*	*	*	4	*	*	*	*	*	*	5
450	DL	4	*	4	4	4	5	5	5	5	*	5	5
600	DL	4	3	4	4	4	5	5	5	5	4	5	5
750	DL	4	3	4	4	4	5	5	5	5	4	5	5
900	DL	4	3	4	4	4	5	5	5	5	4	5	5
1050	DL	4	*	4	4	4	5	5	5	5	*	5	5
1200	DM	4	*	4	4	4	5	5	5	5	*	5	5
1500	DM/F	4	*	4	4	4	5	5	5	5	*	5	5

Cover types

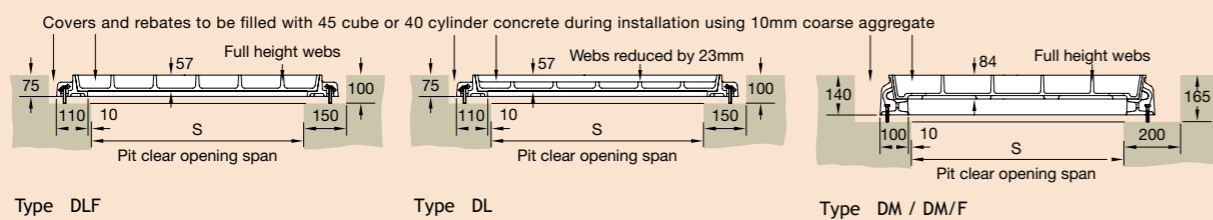

* Indicates standard sizes not available. The number shown indicates the quantity of cover parts. Other standard sizes may be available, refer to our technical department.

B125

Solid top duct covers and frames



- Covers with solid top
- Cover types: DLS, RSD

To specify state:

- Loading group
- Pit clear opening size length (L) x span (S)
- Cover type

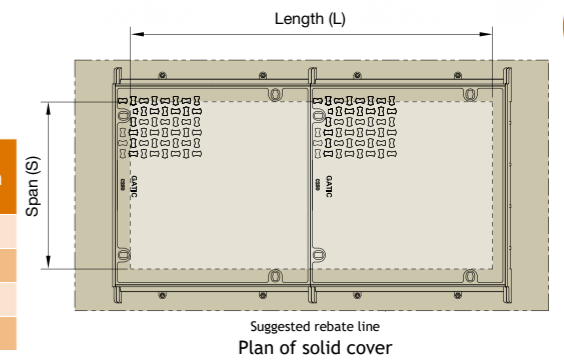

Pit clear opening sizes	Cover type	Suggested rebate size length x width x depth
600	DLS	(L + 300) x 900 x 100
750	DLS	(L + 300) x 1050 x 100
900	DLS	(L + 300) x 1200 x 100
1200	RSD	(L + 400) x 1600 x 125

Pit clear opening span (S)	Cover type	Standard pit clear opening length (L)											
		1300	1450	1600	1750	1900	2000	2150	2300	2450	2600	2700	2750
600	DLS	2	2	2	2	2	3	3	3	3	3	4	3
750	DLS	2	2	2	2	2	3	3	3	3	3	4	3
900	DLS	2	2	2	2	2	3	3	3	3	3	4	3
1200	RSD	2	2	2	*	*	3	3	3	3	*	4	*

Pit clear opening span (S)	Cover type	Standard pit clear opening length (L)											
		2850	2900	3000	3150	3300	3400	3550	3700	3850	3900	4000	4150
600	DLS	4	3	4	4	4	5	5	5	5	4	5	5
750	DLS	4	3	4	4	4	5	5	5	5	4	5	5
900	DLS	4	3	4	4	4	5	5	5	5	4	5	5
1200	RSD	4	*	4	4	4	5	5	5	5	*	5	5

Cover types

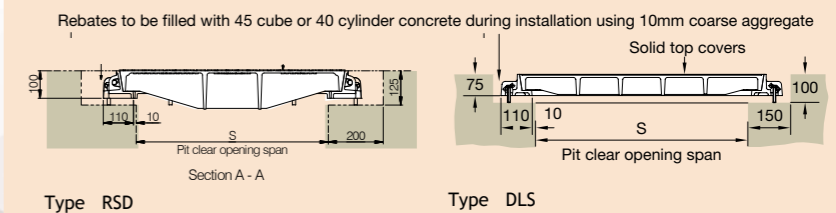

* Indicates standard sizes not available. The number shown indicates the quantity of cover parts. Other standard sizes may be available, refer to our technical department.

Loading Group B125

FOOTWAYS, PEDESTRIAN AREAS, CAR PARKS, DRIVEWAYS AND INTERNAL FLOORS

B125

Continuous recessed trench covers and frames



- Covers recessed for concrete infill
- Cover types: DL, DLF, DM, DM/F

To specify state:

1. Loading group
2. Cover type
3. Supply layout drawing of trenches

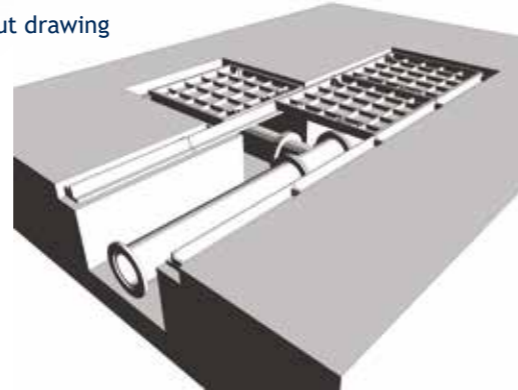

Continuous recessed cover

Pit clear opening span	Cover type
300	DLF
450	DL
600	DL
750	DL
900	DL
1050	DL
1200	DM
1500	DM/F

Note: For type DM/F refer to our technical department



Gatic covers can be formed to make continuous trenches or layouts providing total access to services below.

Construction drawings are required so that Gatic cover layout drawings can be prepared.

Cover types

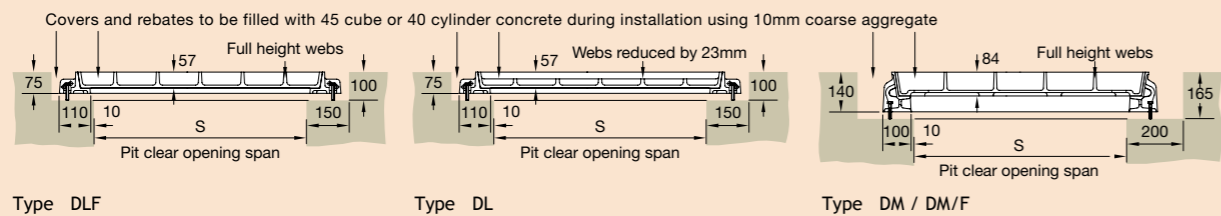

B125

Continuous solid top trench covers and frames

- Covers with solid top
- Cover types: DLS, RSD

To specify state:

1. Loading group
2. Cover type
3. Supply layout drawing of trenches

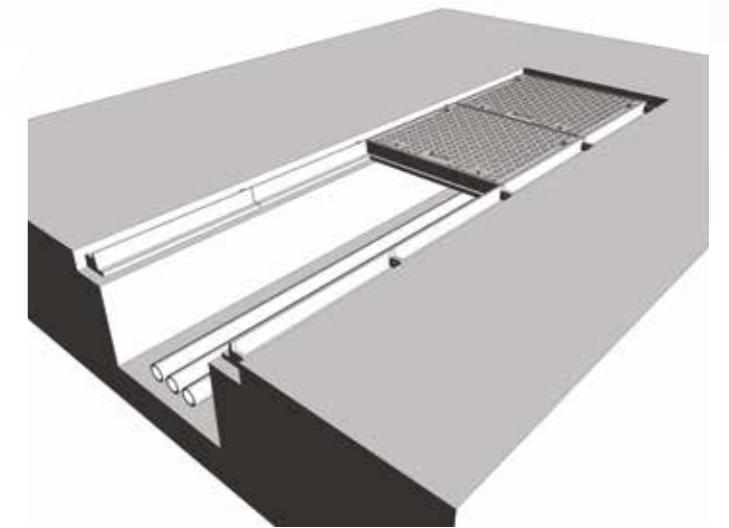

Continuous solid top cover

Pit clear opening span	Cover type
600	DLS
750	DLS
900	DLS
1200	RSD



Standard solid top covers are supplied in straight runs. Junctions and splays can be achieved by the inclusion of localised recessed covers. Refer to our technical department for more information.

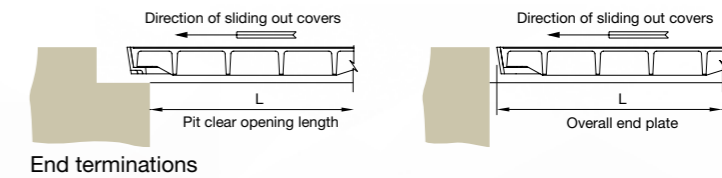

Cover types

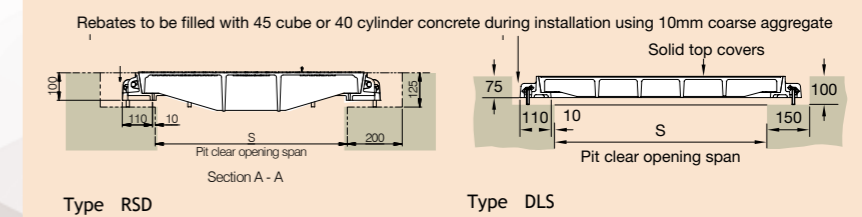

Loading Group B125 FOOTWAYS, PEDESTRIAN AREAS, CAR PARKS, DRIVEWAYS AND INTERNAL FLOORS

Specification

Below is a sample specification information and notes for Multispan recessed covers and frames.

For more details on features and benefits of Gatic covers, see pages 14 to 15.

Loading group Gatic B125

3 tonne wheel load - test load 125 kN.

Materials

Ductile iron components to BS EN 1563.

Structural steel removable beams to BS EN 10365.

Finishes

Units coated with black bituminous solution for protection during transit.

Removable supporting steelwork galvanised to BS EN ISO 1461.

Infill and surround concrete by customer

Concrete strength, using 10mm down coarse aggregate, to be: 45N/mm² for a test cube of 150mm or 40N/mm² for a test cylinder of 150mm diameter x 300mm high.

Installation

In accordance with instructions supplied by Gatic.



Type DL recessed



Type DLS solid top

To specify use size and description format as follows:

Gatic Multispan Recessed covers and frames Cover type DL recessed

Multiple access covers recessed for concrete infill with removable beams.

.... in no. (length) x (span) mm pit clear opening multi span cover and frame. Gatic Type DL Ductile Iron Recessed Cover in parts complete with in no. x mm galvanised removable support beam spanning the (length) mm way.

Suitable for Loading Group B125 - Medium/Light Duty 3 Tonnes Wheel Load (pneumatic tyre).

Gatic Multispan Solid Top covers and frames Cover type DLS solid top

Multiple solid top access covers with removable beams.

.... in no. (length) x (span) mm pit clear opening multi span cover and frame. Gatic Type DLS Ductile Iron Solid Top Cover in parts complete with in no. x mm galvanised removable support beam spanning the (length) mm way.

Suitable for Loading Group B125 - Medium/Light Duty 3 Tonnes Wheel Load (pneumatic tyre).

Standard pit clear opening sizes are shown on Page 91.

Beam sizes and other dimensions are shown on Pages 92 - 93.

For high density traffic conditions refer to page 14.

Product Selection

Refer to the table to identify which cover and beam configuration you require against pit clear opening length (L) and pit clear opening span (S). All dimensions are in millimetres.

		Pit clear opening length (L) mm												Beam centres mm															
		2 parts					3 parts				4 parts			A	B	C	D	E											
		1300	1450	1600	1750	1900	2000	2150	2300	2450	2600	2750	2900	2700	2850	3000	3150	3300	3450	3600	3750	3900							
2 parts 1 beam	1380	[Diagram]					[Diagram]				[Diagram]																		
	1530	[Diagram]					[Diagram]				[Diagram]																		
	1680	[Diagram]					[Diagram]				[Diagram]																		
	1830	[Diagram]					[Diagram]				[Diagram]																		
	1980	[Diagram]					[Diagram]				[Diagram]																		
3 parts 2 beams	2160	[Diagram]					[Diagram]				[Diagram]																		
	2310	[Diagram]					[Diagram]				[Diagram]																		
	2460	[Diagram]					[Diagram]				[Diagram]																		
	2610	[Diagram]					[Diagram]				[Diagram]																		
	2760	[Diagram]					[Diagram]				[Diagram]																		
	2910	[Diagram]					[Diagram]				[Diagram]																		
4 parts 3 beams	3060	[Diagram]					[Diagram]				[Diagram]																		
	2940	[Diagram]					[Diagram]				[Diagram]																		
	3090	[Diagram]					[Diagram]				[Diagram]																		
	3240	[Diagram]					[Diagram]				[Diagram]																		
	3390	[Diagram]					[Diagram]				[Diagram]																		
	3540	[Diagram]					[Diagram]				[Diagram]																		
	3690	[Diagram]					[Diagram]				[Diagram]																		
5 parts 4 beams	3840	[Diagram]					[Diagram]				[Diagram]																		
	3990	[Diagram]					[Diagram]				[Diagram]																		
	4140	[Diagram]					[Diagram]				[Diagram]																		
	3720	[Diagram]					[Diagram]				[Diagram]																		
	3870	[Diagram]					[Diagram]				[Diagram]																		
5 parts 4 beams	4020	[Diagram]					[Diagram]				[Diagram]																		
	4170	[Diagram]					[Diagram]				[Diagram]																		
	4320	[Diagram]					[Diagram]				[Diagram]																		
	4470	[Diagram]					[Diagram]				[Diagram]																		
	4620	[Diagram]					[Diagram]				[Diagram]																		
	4770	[Diagram]					[Diagram]				[Diagram]																		
	4920	[Diagram]					[Diagram]				[Diagram]																		
	5070	[Diagram]					[Diagram]				[Diagram]																		
	5220	[Diagram]					[Diagram]				[Diagram]																		
			[Diagram]					[Diagram]				[Diagram]																	

B125 Multispan Covers & Frames

B125 Multispan Covers & Frames

Loading Group B125

FOOTWAYS, PEDESTRIAN AREAS, CAR PARKS, DRIVEWAYS AND INTERNAL FLOORS

B125



- Covers recessed for concrete infill or solid top
- Cover types: DL (recessed) DLS (solid top)

The details below show plan and sections of a typical recessed/solid top unit. For selection and specification guidance, refer to page 90.

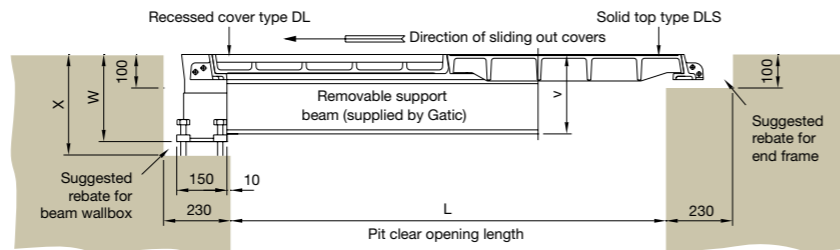
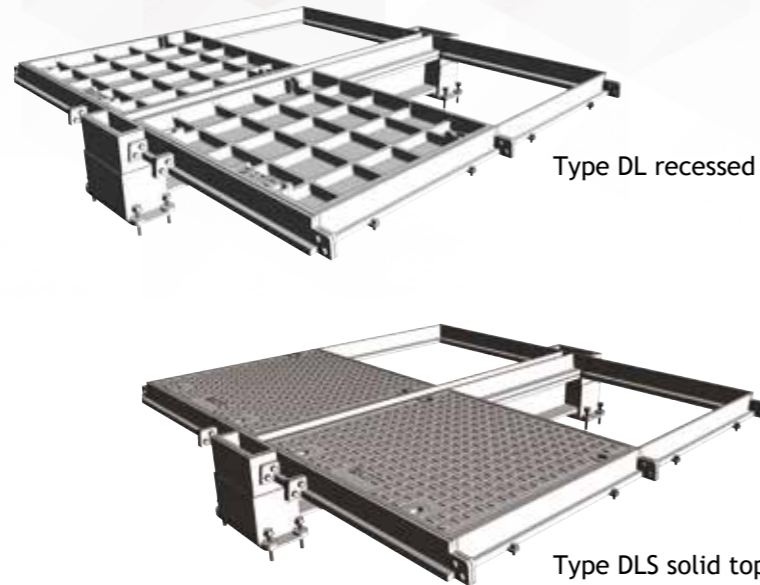

Section A - A

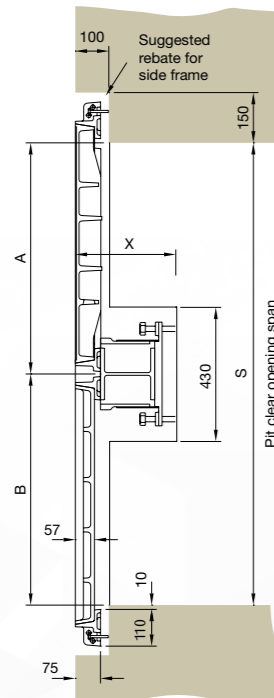

Section B - B

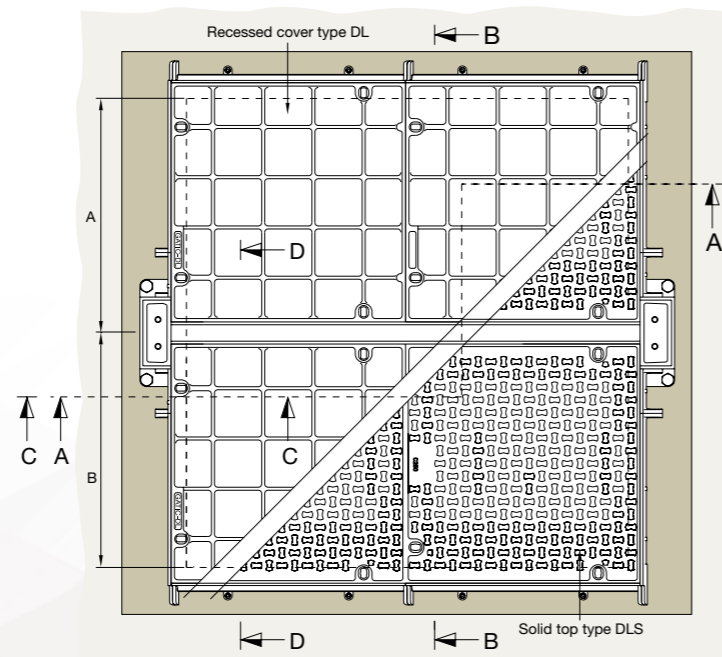

Plan showing recessed and solid top cover options



Beam Size

The required beam size for Multispan covers is dependent on the pit clear opening length and the loading group.

The table shows maximum beam length against beam size. The removable support beams are supplied by Gatic.

The table also indicates dimensions of the beam wallbox and rebate to suit different beam sizes. See also the accompanying section details.

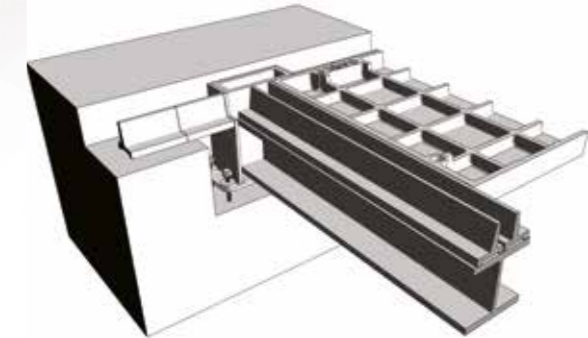

Type DL recessed

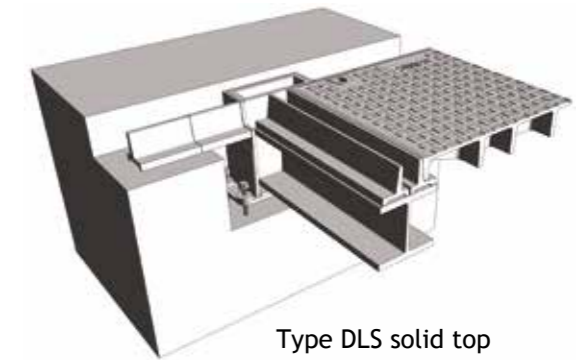

Type DLS solid top

Support beam size chart

Removable support beam size	Max pit clear opening length (L)	Beam wallbox dimensions			
		V	W	X	Y
152 x 152 x 37 kg/m U.C	2750	237	259	300	230
203 x 203 x 52 kg/m U.C.	3900	281	303	345	230

Note: Removable support beams are supplied by Gatic

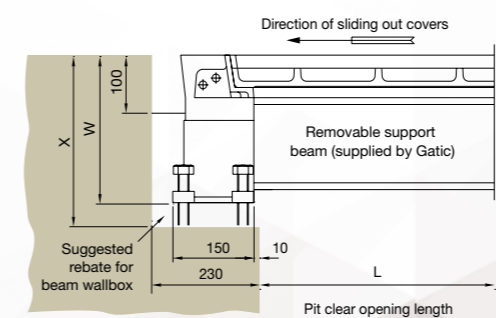

Section C - C

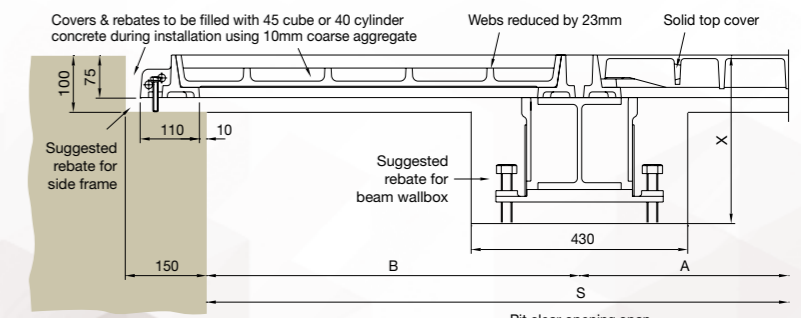

Section D - D

B125

Multispan Covers & Frames

Additional Range of Access Covers & Drainage Grating

- Hinged security grids
- Alternative finish galvanised covers
- Hinged hydrant covers
- Solid top circular covers
- Single gratings and frames
- Trench gratings and frames
- Plug covers

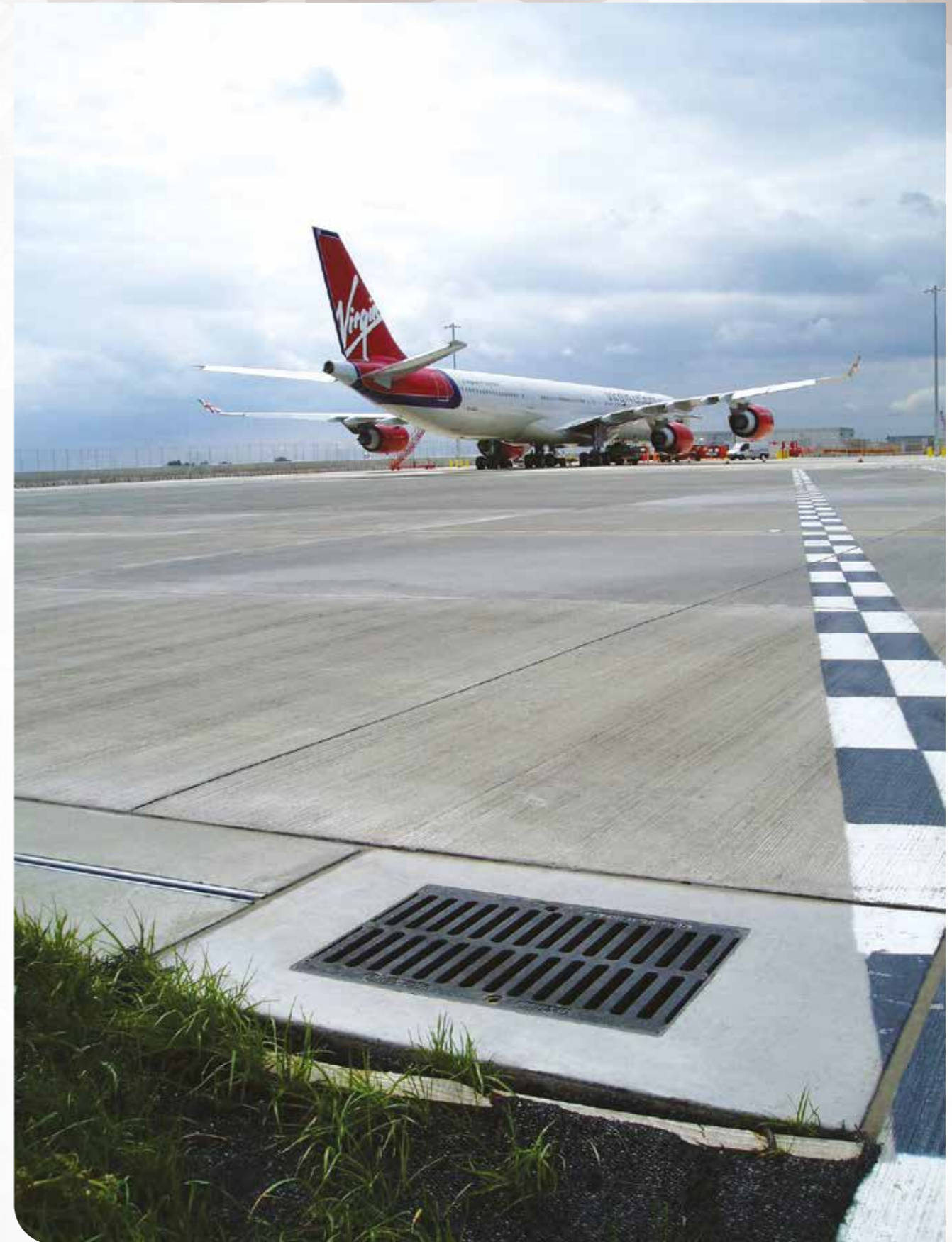
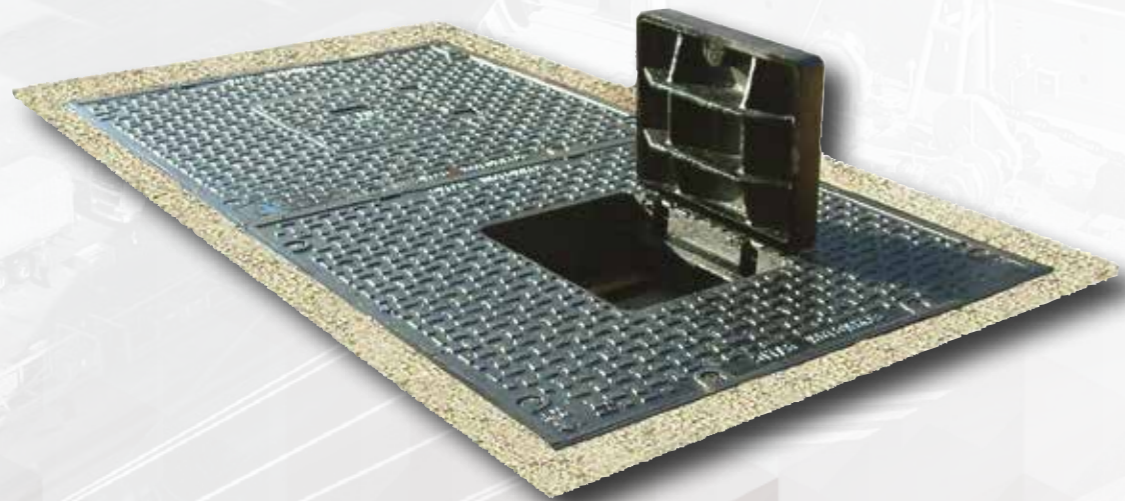
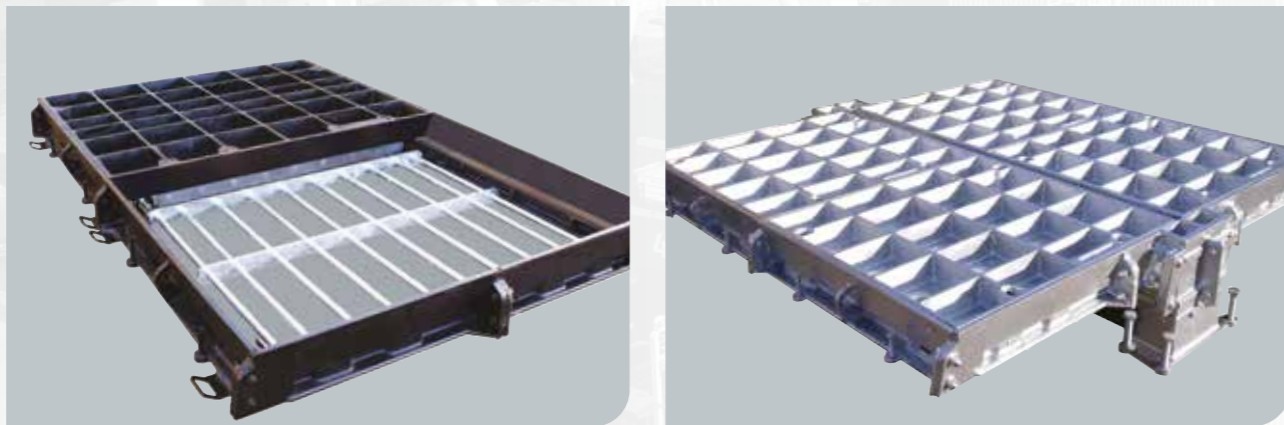

Loading Group up to F900

Hinged security grids

Gatic covers can be supplied with mild steel galvanised security grids when required. Once the cover is removed, the security grid can be hinged to the vertical position where it will lock safely in place. Security grids can be locked in a closed position by using customer-supplied padlocks.

Hinged security grills can be fitted to all gatic units from single covers to multispan.

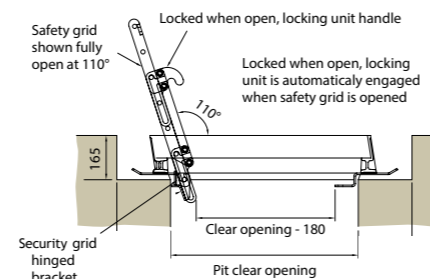
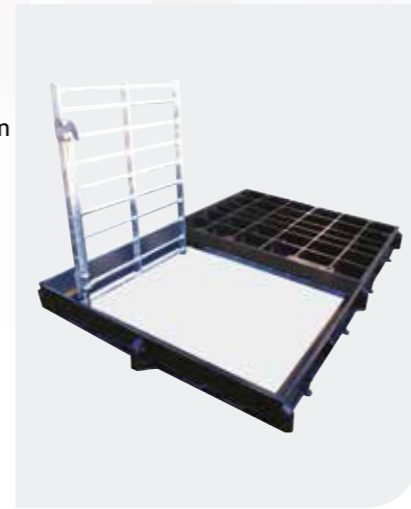
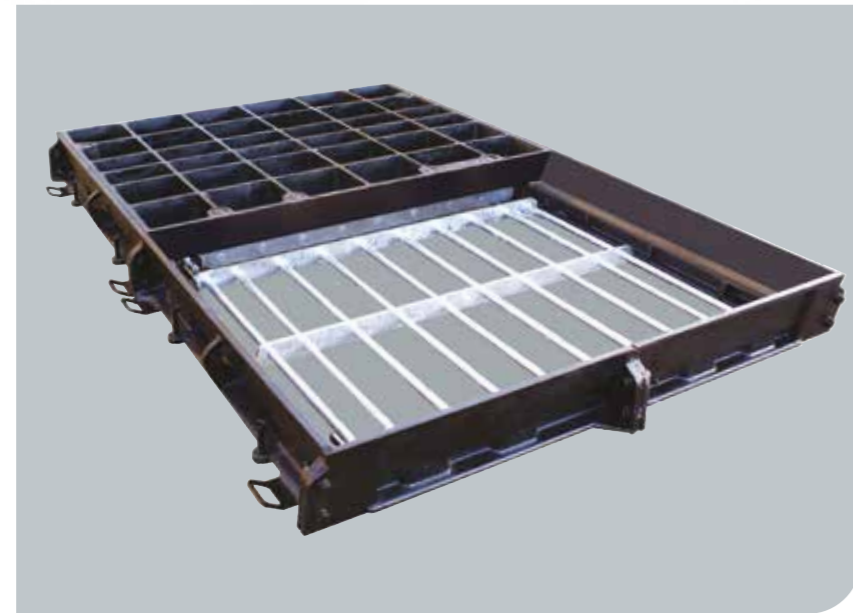

Alternative finish galvanised covers and gratings

Gatic covers and gratings are supplied painted with black bituminous paint as standard. This acts as temporary protection during transit. Where additional protection is required, Gatic ductile iron covers can be supplied galvanised to BS EN ISO 1461. Refer to Gatic technical department for more information.

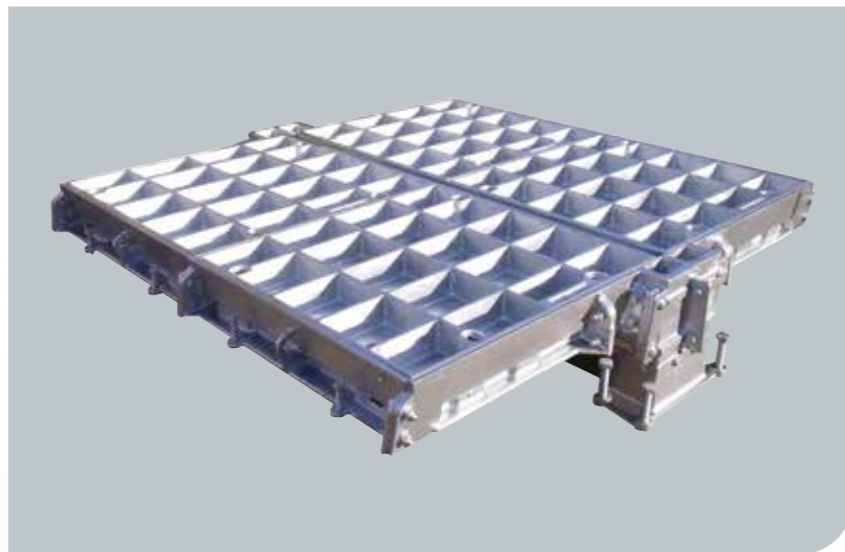

Hinged hydrant covers

Hydrant lids can be supplied as single covers or set into a larger cover. This provides localised access without removing the larger cover.

Hydrants fitted within larger covers are 400 x 300 clear opening, centrally positioned. Can be incorporated into Multi-part Cover Systems.

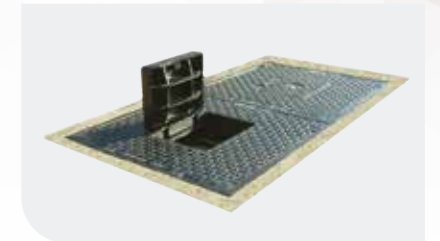

Double hydrant covers

To specify state:

1. Loading group
2. Pit clear opening size length (L) x span (S)
3. Cover type

Single and double covers fitted with 400 x 300 hinged hydrant

Pit clear opening sizes	Cover type	Overall frame size length x width x depth	Suggested rebate size length x width x depth
750 x 750	RSF/H	850 x 940 x 100	1100 x 1100 x 125
900 x 900	RSF/H	1120 x 1140 x 100	1300 x 1300 x 125
1600 x 750	RSF/H	1650 x 940 x 100	1800 x 1100 x 125
1900 x 900	RSF/H	2120 x 1140 x 100	2300 x 1300 x 125

Single and double units - including a 400 x 300 hinged hydrant cover centrally positioned in each cover

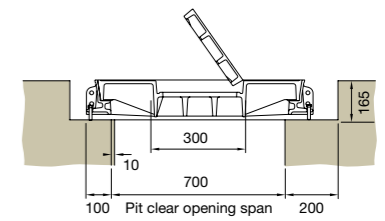

Hydrant covers

Pit clear opening sizes	Cover type	Overall frame size length x width x depth	Suggested rebate size length x width x depth
225 x 225	FH	391 x 391 x 150	525 x 525 x 175
450 x 250	FH	616 x 416 x 150	750 x 550 x 175
500 x 250	FH	666 x 416 x 150	800 x 550 x 175

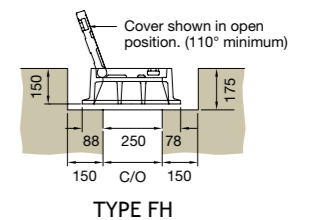

Solid top circular covers

Suitable for up to F900 loading.

To specify state:

1. Loading group
2. Pit clear opening size
3. Cover type

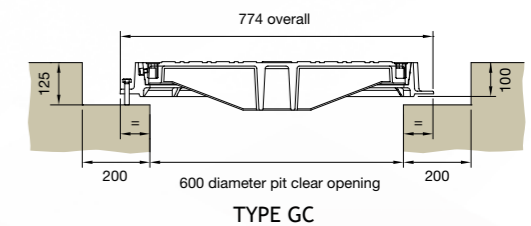

Pit clear opening sizes	Cover type	Overall frame size	Suggested rebate size length x width x depth
600mm diameter	GC	775 diameter	1000 diameter
750mm diameter	GC	925 diameter	1150 diameter
900mm diameter	GC	1075 diameter	1300 diameter

Note: D400 covers available upon request.

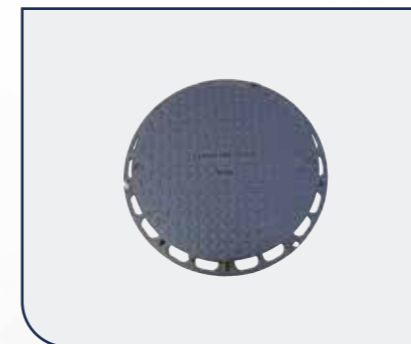

Loading Group up to F900

Single gratings & trench gratings



Single gratings and frames

Drainage gratings are supplied where surface water drainage is required.

To specify state:

1. Loading group
2. Pit clear opening size length (L) x span (S)
3. Grating type



Trench gratings and frames

Gatic gratings and frames can be manufactured in continuous runs.

A layout drawing with enquiries will enable our technical department to design an appropriate layout of gratings.



Single gratings

Pit clear opening sizes	Grating type	Overall frame size length x width x depth	Suggested rebate size length x width x depth	Waterway per unit
850 x 300	DRG/140	870 x 480 x 140	1000 x 700 x 165	1256cm ²
850 x 450	DRG/140	870 x 630 x 140	1000 x 850 x 165	2215cm ²
600 x 600	DRG/100	620 x 780 x 100	750 x 800 x 125	1991cm ²
850 x 600	DMG	870 x 780 x 140	1000 x 1000 x 165	2768cm ²

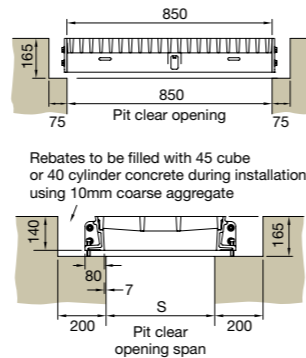

Single gratings with shutter plates

Pit clear opening sizes	Grating type	Overall frame size length x width x depth	Suggested rebate size length x width x depth	Waterway pre unit
914 x 310	DRG/140/S	950 x 480 x 140	1065 x 700 x 165	1256cm ²
914 x 457	DRG/140/S	950 x 630 x 140	1056 x 850 x 165	2215cm ²
914 x 610	DMG/140	950 x 780 x 140	1065 x 1000 x 165	2768cm ²

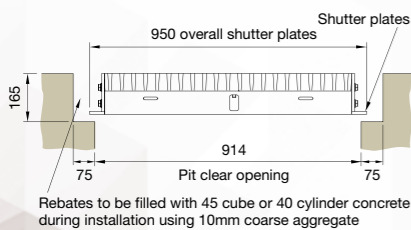

Type DRG/140/S - DMG/S similar

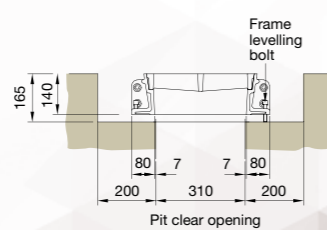

Type DRG/140

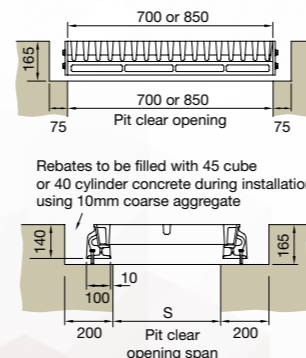

Type DMG

Trench gratings

Pit clear opening sizes	C250 Type	D400 Type	E600 Type	F900 Type	Waterway per metre
300	DRG/100	DRG/100	DRG/100	DRG/100	1813cm ²
450	DRG/100	DRG/100	DRG/100	DRG/100	2629cm ²
600		DRG/100	DRG/100	DRG/100	3445cm ²
750		DRG/100	DRG/100	DRG/100	4329cm ²
810		DRG/100	DRG/100	DRG/100	4466cm ²
1000		DRG/100	DRG/100	DRG/100	5262cm ²

All Type DRG/100 gratings and frames available in 1000mm lengths except 1000mm c/o span for E600/F900 loadings which are 500mm lengths.

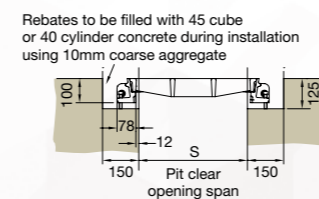

Type DRG/100

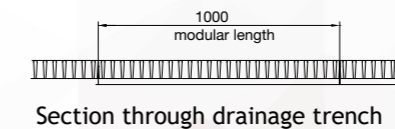

Section through drainage trench

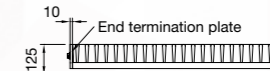

Section through end termination

GATIC range of access covers and drainage gratings up to F900

Loading Group up to C250

Plug covers

Loading groups up to C250

Small insert plug covers can be fitted to a wide range of cover sizes. Maximum 300 x 300 plug clear opening.

Refer to Gatic technical department for more information.

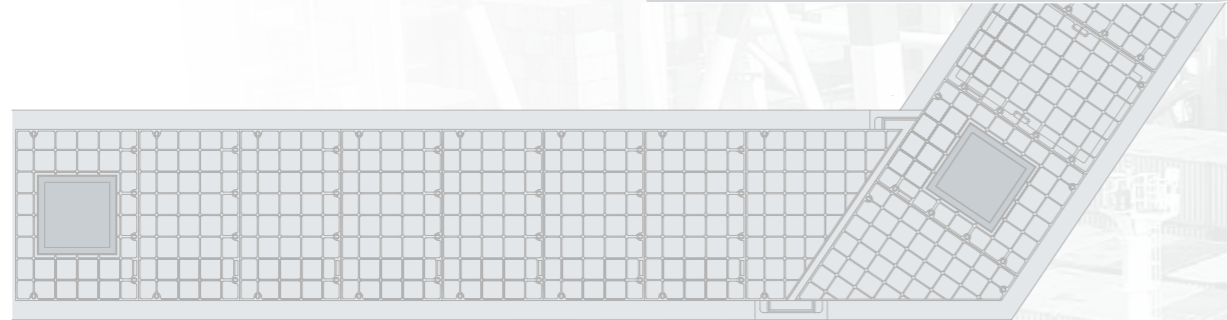
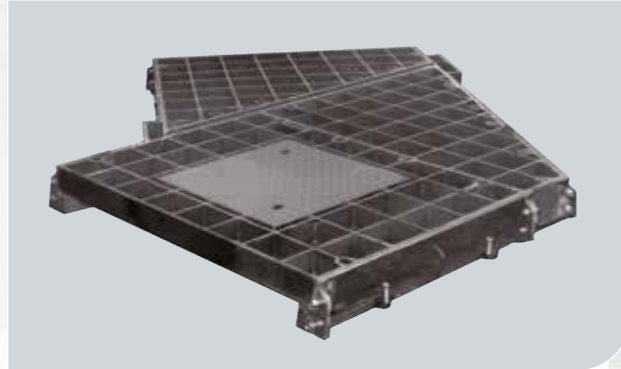

Holes and cut-outs

Holes and cut-outs can be provided in covers to allow for the positioning of valves, pipes and cables. These can be square or circular, loading suitable for C250.

Upstands can be fitted to prevent the ingress of water around pipes and valves.

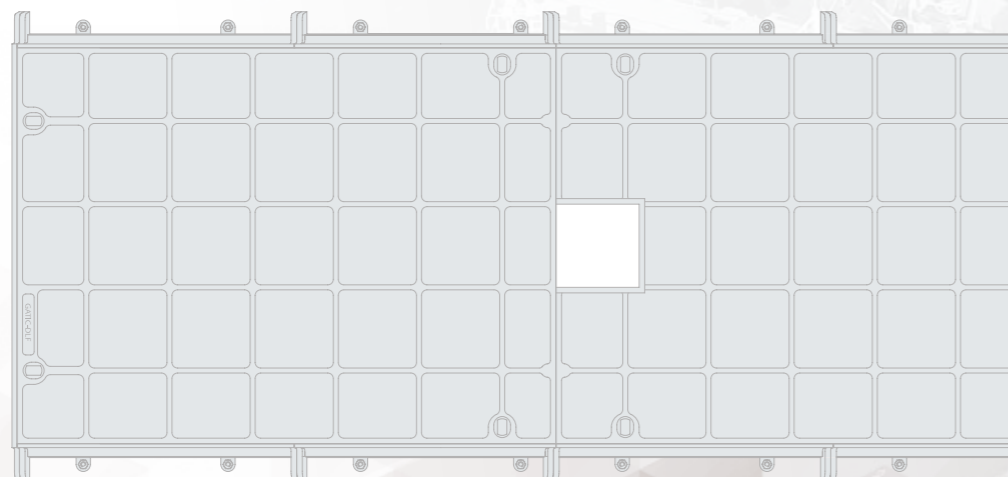

Covers and Frames Installation

Single cover and frames

- 1 Prepare the rebate in accordance with dimensions given in the relevant tables within this publication and/or accompanying drawings.
- 2 Remove cover from frame and place frame squarely over pit ensuring it does not overhang any edges.
- 3 Screw down on the frame levelling bolts until the desired height is achieved.
- 4 Place formwork around inside of pit so that the timber is approximately 10mm above the bottom of the frame. This will prevent spalling of the frame.

Do not pour concrete at this stage.

- 5 Clean off cover and frame sealing faces and replace cover into frame.
- 6 Adjust the frame level so that the cover is not rocking. Tap down the corners of the covers with a balk of timber to make sure it is seated fully.
- 7 If covers are of the recessed design you will need to cover the 4 holes in the cover base with a small metal or slate plate.
- 8 Insert the plastic keyhole plugs and mask off with tape.
- 9 Pour concrete in the covers, if of the recessed type, and around the frames making sure that you thoroughly tamp and vibrate as you go.
- 10 Allow concrete to cure overnight.
- 11 Remove cover and strike shuttering.
- 12 Clean faces of covers and frame and apply a thin film of graphite grease to the seating faces.
- 13 Replace cover into the frame and tap down with a balk of timber.
- 14 Allow the concrete to fully mature before any load is applied.

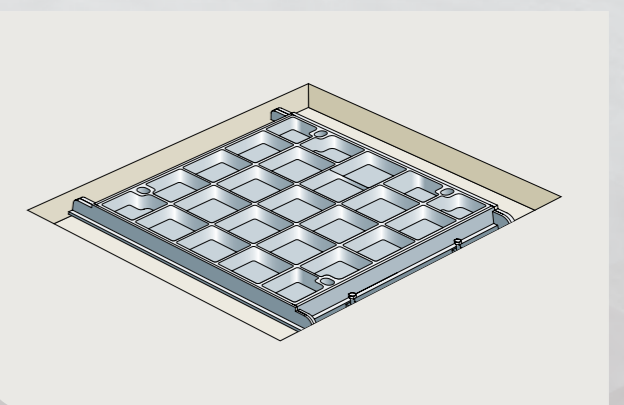
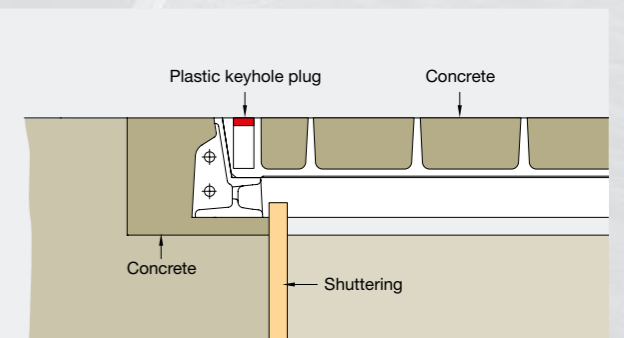
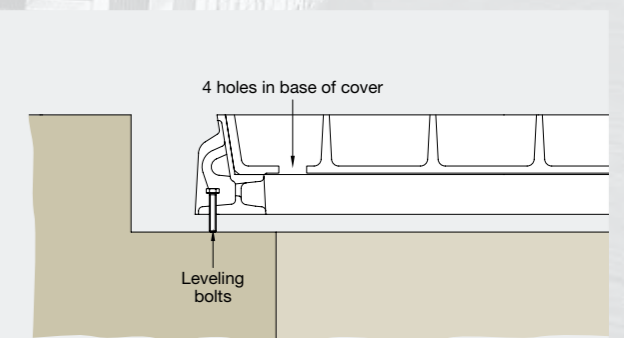
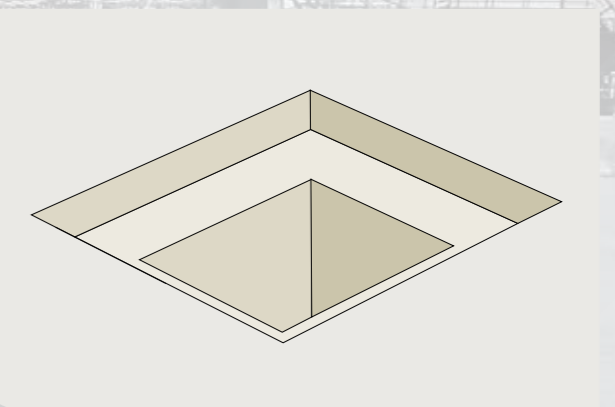

Covers and Frames Installation

Ducts and trenches

- 1 Prepare the rebate in accordance with dimensions given in the relevant tables within this publication and/or accompanying drawings. They are also numbered in sequence.
- 2 Covers and frames are supplied pre-matched and banded together.

Do not remove banding at this stage.

- 3 Commence at one end of the pit, or if there is a junction then commence at this point. Identify the relevant covers and frames at this location.
- 4 Place first assembled section squarely over the pit ensuring it is in alignment with the centre of the pit.
- 5 Identify the next assembly. This is done by locating the next number in the sequence, offering up to the first portion and loosely bolting the frame together. Numbers are painted on the ends of the covers to correspond with the drawings supplied.
- 6 Adjust the height of the frames to the required level by using the levelling bolts in the frame.
- 7 Repeat along the length of the trench making sure the covers are following a straight line.
- 8 Visually check that your covers are in the correct frames and order by looking for the random grinding nicks around each cover perimeter on the top surface.
- 9 In sections, remove covers from frames and place formwork around inside of pit so that the timber is approximately 10mm above the bottom of the frame. This will prevent spalling of the frame.

Do not pour concrete at this stage.

- 10 Clean off covers and frame seating faces and replace cover into the frame.
- 11 Check that the grinding nicks still correspond.
- 12 Adjust the frame level so that the cover is not rocking. Tap down the corners of the covers with a balk of timber to make sure it is seated fully.
- 13 Using the assembly clamps provided, clamp the covers to the frames and across cover to cover joints. This will ensure that the covers are seated properly.
- 14 Moving round the frame, with the covers in place, tighten the frame bolts making sure you do not damage the lead packers or over-tighten the bolt.
- 15 If covers are of the recessed design, you will need to

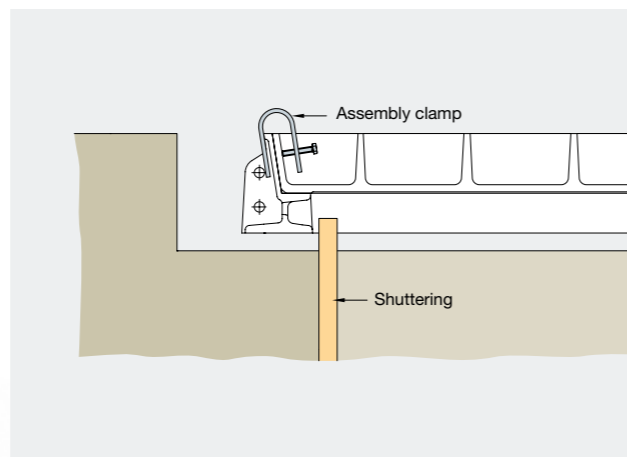
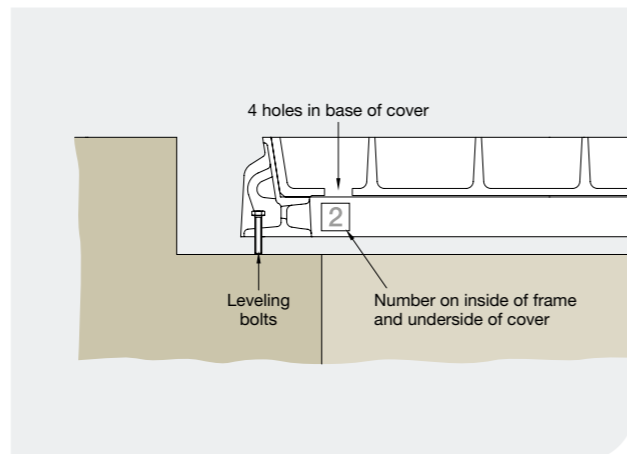
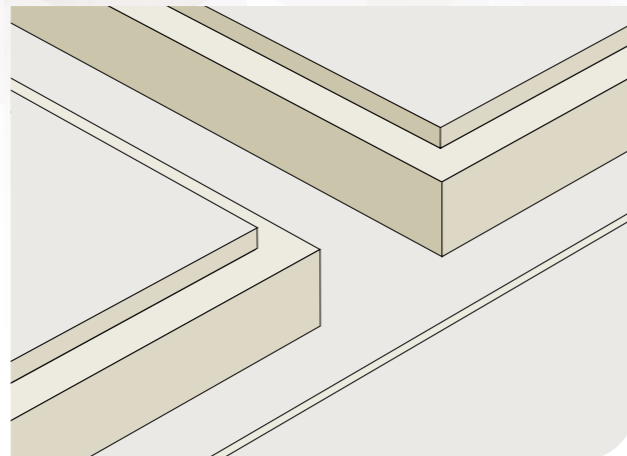

cover the small holes in the cover base with a small metal or slate plate.

Ducts and trenches

(continued)

- 16 Insert the plastic keyhole plugs and mask off with tape.
- 17 Pour concrete around the frames to a depth of about 25mm up the back of the frame and tamp or vibrate as you go.
- 18 Allow to cure overnight then remove the assembly clamps.
- 19 Pour concrete into the recessed covers, and around the frames, making sure that you thoroughly tamp and vibrate as you go.
- 20 Allow concrete to cure overnight.
- 21 Remove cover and strike shuttering.
- 22 Clean faces of covers and frame and apply a thin film of graphite grease to the seating faces.
- 23 Replace cover into the frame and tap down with a balk of timber. Once again make sure that the grinding nicks match up.
- 24 Allow the concrete to fully mature before any load is applied.

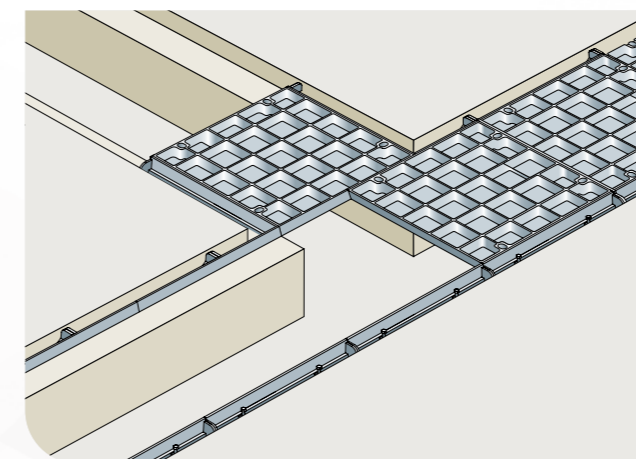
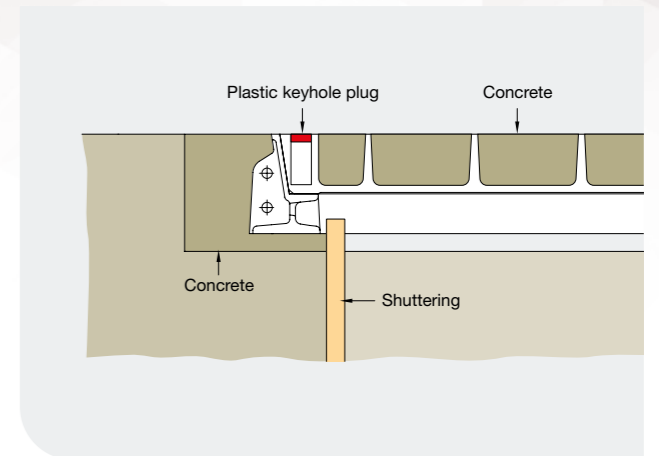

INSTALLATION

Covers and Frames Installation

Multispan covers and frames

Form the frame and wallbox rebates around the pit strictly in accordance with Gatic's drawing. It is important to follow the stated dimensions otherwise the multispan cover will not fit.

The frame is delivered in sections together with beam assemblies and covers. Ensure that the end frames match with the side frame components.

The end frames can be identified as those sections with the beam end wallbox forming part of their construction. Frame sections and beam assemblies are numbered to help locate the cover positions.

Identification numbers are shown on the cover layout drawing supplied. Numbers can be found painted on the ends of covers, beams and outside faces of frames. Number tags are also fixed to the underside of the cover and also to the frame and beams.

The lowest numbers in each row of covers indicate that this is the front end of the unit.

- 1 Position the front end frames in the wallbox pockets and loosely join the sections together in the middle and at the corners.
- 2 Locate the side frame assemblies. These are handed so that they only fit on the correct side of the cover, and offer up to the back end frames. Remember that there are a number of small frame pieces that make up a straight frame.
- 3 Check that lead spacers at the frame joints have not been damaged otherwise the frame will no longer mate with the cover. Again loosely bolt the frames together.
- 4 Using the large 'Tommy Bar' gradually screw down on the levelling bolts on the bottom of the wallboxes until the top of the frame is approximately level with the finished floor level.
- 5 Now using the small 'Tommy Bar' adjust the side frames up to approximate finished level.
- 6 Locate the correct beam assembly, look for the numbers painted on the beam and corresponding tags on the frame, and lower into the wallboxes.
- 7 Tap down on the filler block, using a rubber mallet, and then, using the small assembly clamp, clip the end of the beam into the wallbox. (If the filler block is not flush then the beam is not seated correctly in the wallbox and you will need to adjust it accordingly).
- 8 Dimensionally check the frame is roughly square and not overhanging the edge of the pit.

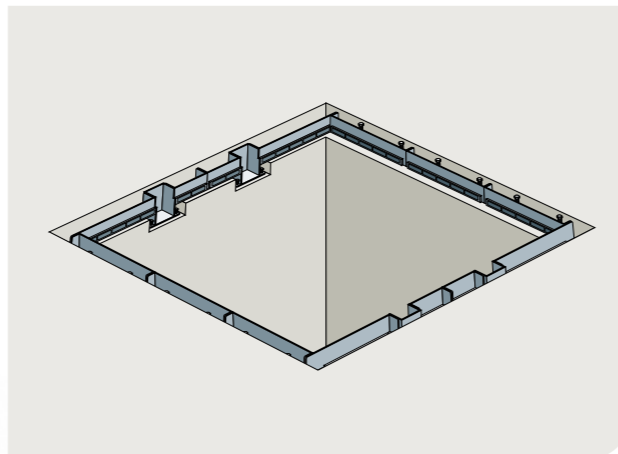
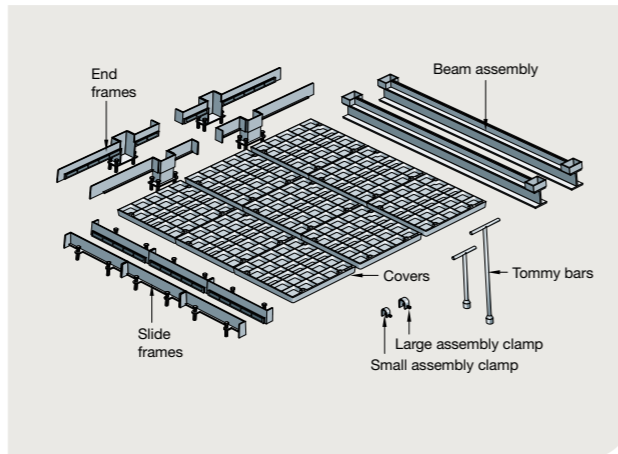
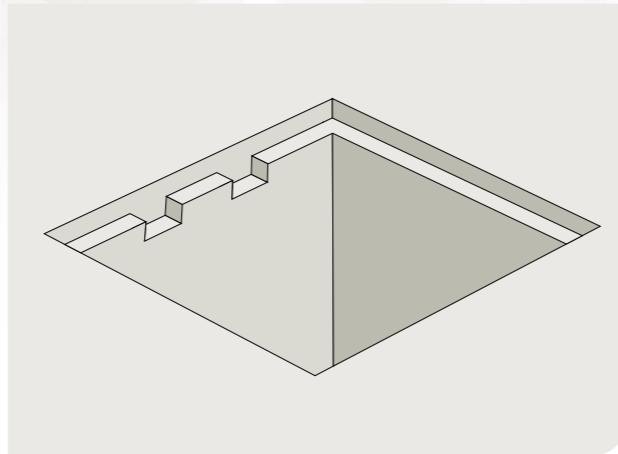

Multispan covers and frames (continued)

Do not pour concrete at this stage.

- 9 Clear any debris from the seating faces of the covers and frames and, starting with the middle row, lay the three covers down between the two beams.
- 10 With the three covers in position, adjust the wallbox levelling bolts to attain the required height, and also to make sure that the covers are seated correctly and not rocking.
- 11 Position one of the outer rows and this time adjust the levelling bolts until the covers do not rock.
- 12 Repeat for the other end row. The covers are now sound enough to walk on to check that they are not rocking.
- 13 Walk across the covers and tap the corners with a balk of timber to ensure that they are firmly down.
- 14 Using the assembly clamps provided, you can now pull the covers tightly together and into the frames to ensure the unit is correctly seated.
- 15 Visually check the top edges of the covers and frames making sure that random grinding marks align with each other.
- 16 Now go round the frame and tighten all loose connected frame joints, but do not over-tighten. They only need to be nipped up.
- 17 Remove the covers and carefully stack at the side of the pit.
- 18 Place timber shuttering around the inside perimeter of the pit and brace as appropriate. The shuttering should sit approximately 10mm higher than the bottom of the frame.
- 19 Replace the covers, taking care that they are in the correct location, check that there is still no rock, and then clamp the covers in place as before.

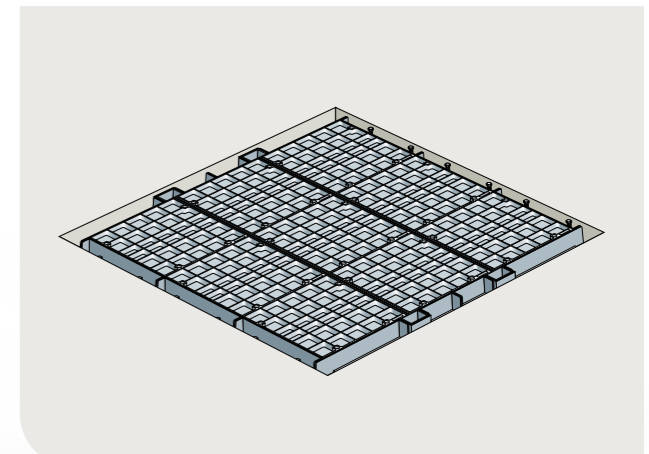
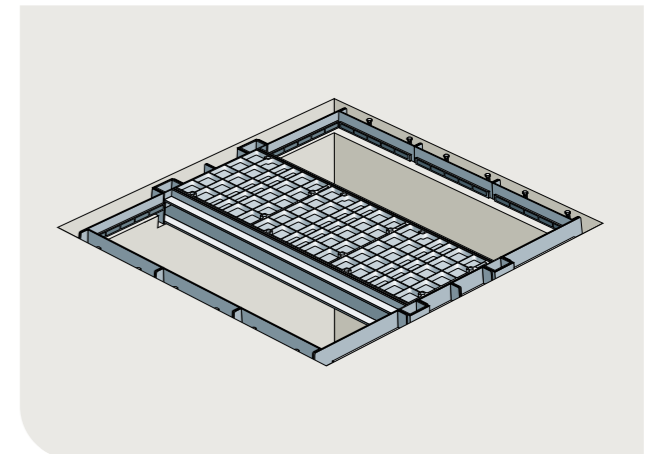
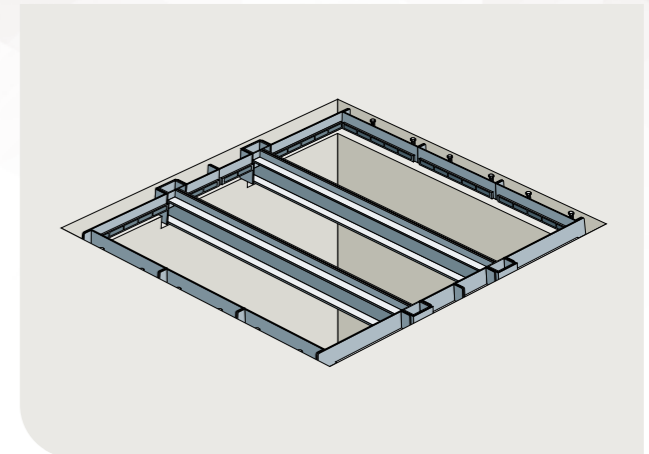

Covers and Frames Installation

Multispan covers and frames

(continued)

- 20 Place small thin pieces of cut steel over the holes in the cover base plates, insert keyhole plugs and place masking tape over them. The cover is now ready to receive concrete.
- 21 Leave the assembly clamps in place and part fill the rebate around the frame, going approximately 25mm up the back of the frame and thoroughly tamping or vibrating to ensure that it flows under the frame. Leave for 24 hours to set.
- 22 Remove clamps and proceed to infill around the rest of the frame and inside the covers, thoroughly tamping as you go.
- 23 Float off the surface to the desired texture.
- 24 Remove covers from the frames and strike the shuttering, checking that the concrete has fully flowed under the frame.
- 25 Clean off covers and beams.
- 26 Lightly grease the blocks on the end of the beams and place in position.
- 27 Lightly grease faces and covers and replace in frames, checking that the grinding marks align.
- 28 Allow the concrete to fully mature before any load is applied.

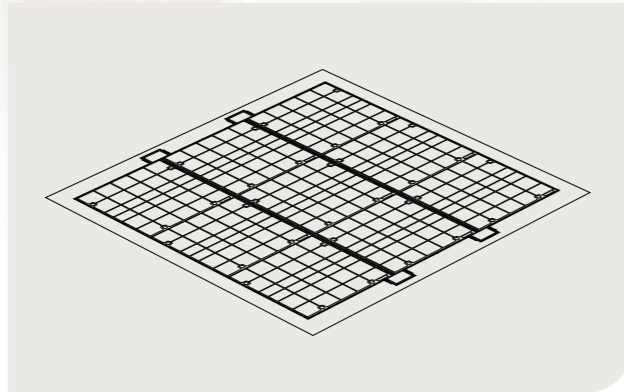

Gatic tutorial



Please contact our technical team on +44 (0)1787 475151

Lifting keys

Manual jack screw key operation.

Method of removing Gatic covers using manual lifting keys.

- 1 Clear all obstructions from key holes.
- 2 Slacken off jack screw before placing key in position.
- 3 Insert tee bolt in the key hole, turn clockwise through 90° and tighten lock nut.
- 4 Jack screw can now be tightened to act on the frame and break seal.
- 5 Lift front and slide out cover.
- 6 Slacken off jack screw before replacing cover.



Long handled lifting keys (pair)

Not for use with mechanical or crane lifting.

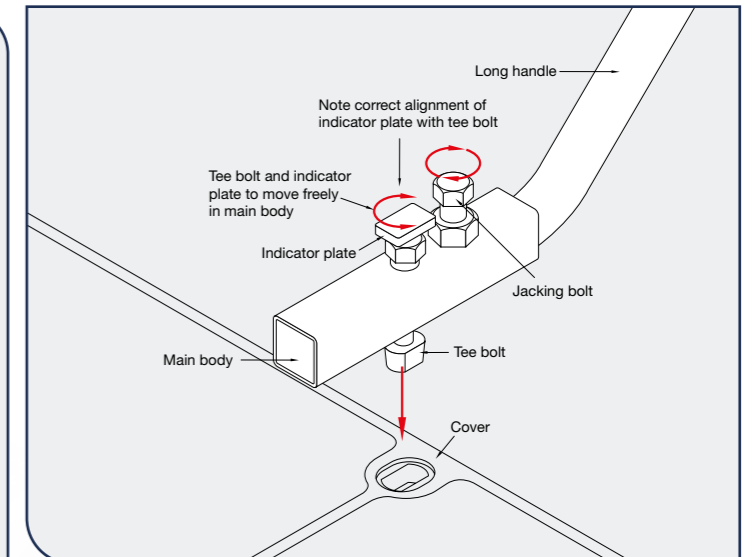
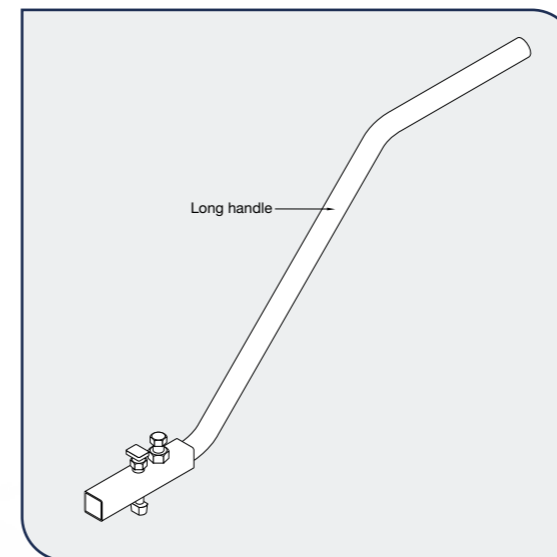
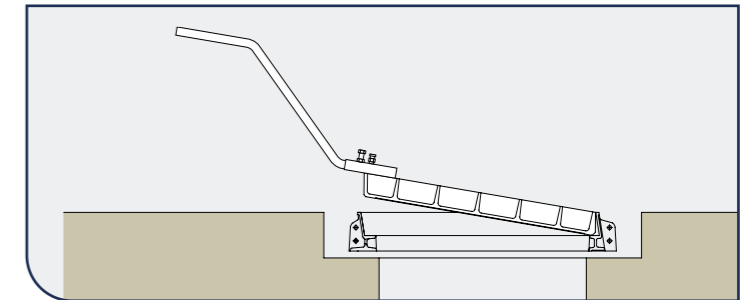

Mechanical lifting keys

Mechanical lifting keys are designed and tested for use with crane and other mechanical devices.

Consult technical department for full details.

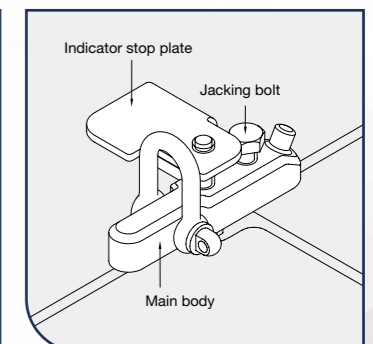
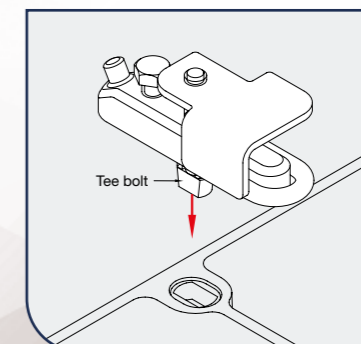

GATIC[®]

DRAINAGE & ACCESS COVERS

www.gatic.com

Gatic
Third Avenue
Halstead
Essex
C09 2SX

+44 (0)1787 475 151
gatictech@alumascwms.co.uk

ALUMASC[®]

WATER MANAGEMENT SOLUTIONS

