



# 317 GC

## Hydraulic Excavator

# Technical Specifications

Configurations and features may vary by region. Please consult your Cat® dealer for availability in your area.

## Table of Contents

<b>Specifications</b> .....	<b>2</b>
Engine .....	2
Weights .....	2
Track .....	2
Drive .....	2
Hydraulic System .....	2
Service Refill Capacities .....	2
Standards .....	2
Sound Performance .....	2
Air Conditioning System .....	2
Operating Weights and Ground Pressures .....	3
Major Component Weights .....	3
Dimensions .....	4
Working Ranges .....	5
Blade Working Ranges .....	6
Reach Boom Lift Capacities:	
With Blade .....	7
Without Blade .....	9
Bucket Specifications and Compatibility .....	15
Attachments Offering Guide .....	17
<b>Standard and Optional Equipment</b> .....	<b>21</b>
<b>Dealer Installed Kits and Attachments</b> .....	<b>23</b>
<b>317 GC Environmental Declaration</b> .....	<b>24</b>

# 317 GC Hydraulic Excavator Specifications

## Engine

Engine Model	Cat® C3.6	
Net Power		
ISO 9249	89 kW	119 hp
ISO 9249 (DIN)	121 hp (metric)	
Engine Power		
ISO 14396	90 kW	121 hp
ISO 14396 (DIN)	122 hp (metric)	
Bore	98 mm	4 in
Stroke	120 mm	5 in
Displacement	3.6 L	220 in <sup>3</sup>
Biodiesel Capability	Up to 20% <sup>(1)</sup>	

- Meets U.S. EPA Tier 4 Final and EU Stage V emission standards.
- No engine power derate required below 3000 m (9,840 ft) altitude.
- Advertised power is tested per the specified standard in effect at the time of manufacture.
- Net power advertised is the power available at the flywheel when the engine is equipped with fan, air intake system, exhaust system and alternator.
- Engine speed at 2,400 rpm.

<sup>(1)</sup>Cat diesel engines are required to use ULSD (ultra-low sulfur diesel fuel with 15 ppm of sulfur or less) or ULSD blended with the following lower-carbon intensity fuels\*\* up to:

- ✓ 20% biodiesel FAME (fatty acid methyl ester)\*
- ✓ 100% renewable diesel, HVO (hydrotreated vegetable oil) and GTL (gas-to-liquid) fuels

Refer to guidelines for successful application. Please consult your Cat dealer or “Caterpillar Machine Fluids Recommendations” (SEBU6250) for details.

*\*Engines with no aftertreatment devices can use higher blends, up to 100% biodiesel (for use of blends higher than 20% biodiesel, consult your Cat dealer).*

*\*\*Tailpipe greenhouse gas emissions from lower-carbon intensity fuels are essentially the same as traditional fuels.*

## Swing Mechanism

Swing Speed*	8.7 rpm	
Maximum Swing Torque	61 kN·m	44,991 lbf·ft

\*For CE-marked machine default value may be set lower.

## Weights

Operating Weight	17 100 kg	37,600 lb
------------------	-----------	-----------

- Long undercarriage, Reach boom, R2.9 (9'6") stick, General Duty (GD) 1.00 m<sup>3</sup> (1.31 yd<sup>3</sup>) bucket, 500 mm (20") triple grouser shoes and 3.05 mt (6,720 lb) counterweight.

## Track

Standard Track Shoes Width	500 mm	20 in
Optional Track Shoes Width	600 mm	24 in
Optional Track Shoes Width	700 mm	28 in
Number of Shoes (each side)	44	
Number of Track Rollers (each side)	7	
Number of Carrier Rollers (each side)	2	

## Drive

Gradeability	35°/70%	
Maximum Travel Speed	5.3 km/h	3.3 mph
Maximum Drawbar Pull	157 kN	35,295 lbf

## Hydraulic System

Main System – Maximum Flow – Implement	296 L/min	78 gal/min
Maximum Pressure – Equipment	35 000 kPa	5,075 psi
Maximum Pressure – Travel	35 000 kPa	5,075 psi
Maximum Pressure – Swing	25 800 kPa	3,741 psi
Boom Cylinder – Bore	110 mm	4 in
Boom Cylinder – Stroke	1193 mm	47 in
Stick Cylinder – Bore	120 mm	5 in
Stick Cylinder – Stroke	1331 mm	52 in
Bucket Cylinder – Bore	105 mm	4 in
Bucket Cylinder – Stroke	1039 mm	41 in

## Service Refill Capacities

Fuel Tank Capacity	271 L	71.6 gal
Cooling System	22 L	5.8 gal
Engine Oil	11 L	2.9 gal
Final Drive (each)	6 L	1.6 gal
Hydraulic System (including tank)	94 L	24.8 gal
Hydraulic Tank	87 L	23.0 gal
Diesel Exhaust Fluid (DEF) Tank	22 L	5.9 gal

## Standards

Brakes	ISO 10265:2008
Cab/Rollover Protective Structure (ROPS)	ISO 12117-2:2008
Cab/Operator Protective Guards (OPG) (optional)	ISO 10262:1998 (Level II)

## Sound Performance

ISO 6395:2008 (external)	101 dB(A)
ISO 6396:2008 (inside cab)	70 dB(A)

- Hearing protection may be needed when operating with an open operator station and cab (when not properly maintained or doors/windows open) for extended periods or in a noisy environment.

## Air Conditioning System

The air conditioning system on this machine contains the fluorinated greenhouse gas refrigerant R134a (Global Warming Potential = 1430). The system contains 0.9 kg of refrigerant, which has a CO<sub>2</sub> equivalent of 1.287 metric tonne.

# 317 GC Hydraulic Excavator Specifications

## Operating Weights and Ground Pressures

	500 mm (20")		600 mm (24")		700 mm (28")		790 mm (31")	
	Triple Grouser Shoes		Triple Grouser Shoes		Triple Grouser Shoes		Triple Grouser Shoes	
	Weight	Ground Pressure	Weight	Ground Pressure	Weight	Ground Pressure	Weight	Ground Pressure
	kg (lb)	kPa (psi)	kg (lb)	kPa (psi)	kg (lb)	kPa (psi)	kg (lb)	kPa (psi)
<b>Base Machine with 3.05 mt (6,720 lb) Counterweight and Long Undercarriage</b>								
Reach Boom + R2.6 (8'6") Stick + 1.00 m <sup>3</sup> (1.31 yd <sup>3</sup> ) GD Bucket	17 000 (37,500)	48.3 (7.0)	17 200 (38,000)	40.8 (5.9)	17 500 (38,500)	35.4 (5.1)	17 800 (39,300)	32.1 (4.7)
Reach Boom + R2.9 m (9'6") Stick + 1.00 m <sup>3</sup> (1.31 yd <sup>3</sup> ) GD Bucket	17 100 (37,600)	48.5 (7.0)	17 300 (38,100)	40.9 (5.9)	17 500 (38,600)	35.6 (5.2)	17 900 (39,500)	32.2 (4.7)
Reach Boom + R2.6 m (8'6") Stick + 1.00 m <sup>3</sup> (1.31 yd <sup>3</sup> ) + GD Bucket + Blade	17 900 (39,400)	48.5 (7.0)	18 100 (39,900)	48.5 (7.0)	18 400 (40,500)	48.5 (7.0)	18 700 (41,300)	48.5 (7.0)
Reach Boom + R2.9 m (9'6") Stick + 1.00 m <sup>3</sup> (1.31 yd <sup>3</sup> ) + GD Bucket + Blade	17 900 (39,500)	48.5 (7.0)	18 200 (40,100)	48.5 (7.0)	—	—	—	—

All operating weights include a 90% fuel tank with 75 kg (165 lb) operator.

## Major Component Weights

	kg	lb
Base Machine (with 3.05 mt [6,720 lb] counterweight, upper frame [including swing frame], long undercarriage – does not include boom, stick, bucket, boom cylinders, stick cylinder, bucket cylinders, tracks, 90% fuel tank and 75 kg [165 lb] operator).	11 430	25,200
Track Shoes:		
500 mm (20") Triple Grouser Track Shoes	2110	4,660
600 mm (24") Triple Grouser Track Shoes	2340	5,160
700 mm (28") Triple Grouser Track Shoes with Additional Steps	2580	5,680
790 mm (31") Offset Triple Grouser Track Shoes with Additional Steps	2970	6,550
Two Boom Cylinders	300	670
Weight of 90% Fuel Tank and 75 kg (165 lb) Operator	300	660
Counterweight:		
3.05 mt (6,720 lb) Counterweight	3050	6,720
Swing Frame	1690	3,720
Undercarriage:		
Base Frame with Long Undercarriage	3900	8,600
Boom (including lines, pins, stick cylinder):		
Reach Boom (5.1 m/16'9")	1320	2,910
Sticks (including lines, pins, bucket cylinder, bucket linkage):		
Reach Stick (R2.6 m/8'6")	810	1,780
Reach Stick (R2.9 m/9'6")	880	1,930
Bucket (without linkage):		
1.00 m <sup>3</sup> (1.31 yd <sup>3</sup> ) GD Bucket	740	1,620
Quick Coupler:		
Pin Grabber Quick Coupler	260	580

# 317 GC Hydraulic Excavator Specifications

## Dimensions

All dimensions are approximate and may vary depending on bucket selection.

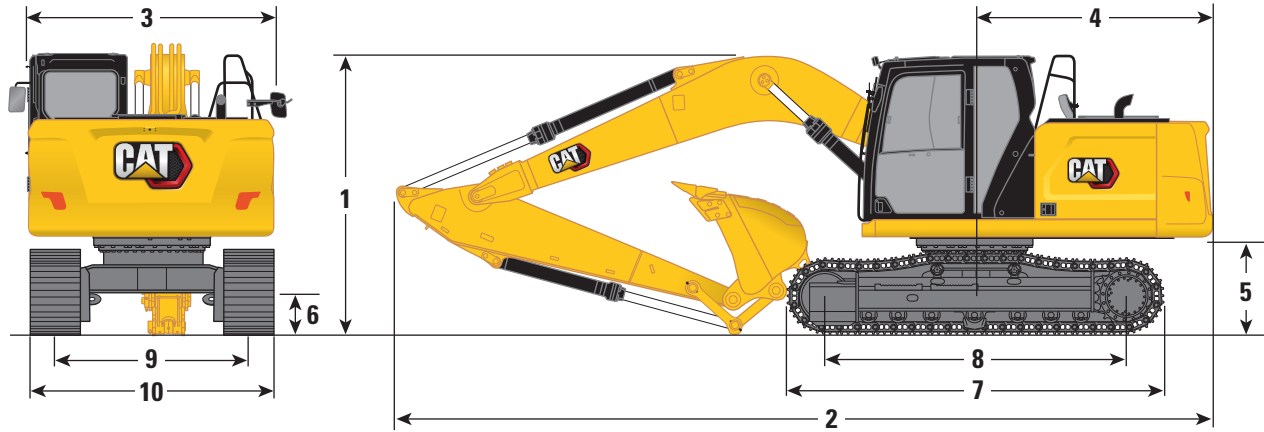

### Boom Option

### Reach Boom 5.1 m (16'9")

### Stick Options

### Reach Stick R2.6 (8'6")

### Reach Stick R2.9 (9'6")

	2930 mm	9'7"	2930 mm	9'7"
<b>1</b> Machine Height:				
Top of Cab Height	2930 mm	9'7"	2930 mm	9'7"
Top of OPG Height	3070 mm	10'1"	3070 mm	10'1"
Handrail Height	2940 mm	9'8"	2940 mm	9'8"
With Boom/Stick/Bucket Installed (with stick cylinder lines)	2980 mm	9'9"	3040 mm	9'11"
With Boom/Stick Installed (with stick cylinder lines)	2880 mm	9'5"	2920 mm	9'7"
With Boom Installed (with stick cylinder lines)	2460 mm	8'1"	2460 mm	8'1"
<b>2</b> Machine Length:				
With Boom/Stick/Bucket Installed (with stick cylinder lines)	8560 mm	28'1"	8570 mm	28'1"
With Boom/Stick Installed (with stick cylinder lines)	8530 mm	27'11"	8550 mm	28'1"
With Boom Installed (with stick cylinder lines)	7560 mm	24'10"	7560 mm	24'10"
Machine Length (with Blade, Blade Rear):				
with boom/stick/bucket installed (with stick cylinder lines)	8600 mm	28'2"	8620 mm	28'3"
with boom/stick installed (with stick cylinder lines)	8570 mm	28'1"	8600 mm	28'2"
with boom installed (with stick cylinder lines)	7670 mm	25'2"	7670 mm	25'2"
<b>3</b> Upperframe Width	2540 mm	8'4"	2540 mm	8'4"
<b>4</b> Tail Swing Radius:				
3.05 mt (6,720 lb) Counterweight	2500 mm	8'2"	2500 mm	8'2"
<b>5</b> Counterweight Clearance	1010 mm	3'4"	1010 mm	3'4"
<b>6</b> Ground Clearance	430 mm	1'5"	430 mm	1'5"
<b>7</b> Track Length	3970 mm	13'0"	3970 mm	13'0"
<b>8</b> Length to Center of Rollers	3170 mm	10'5"	3170 mm	10'5"
<b>9</b> Track Gauge	1990 mm	6'6"	1990 mm	6'6"
<b>10</b> Undercarriage Width:				
500 mm (20") Shoes	2490 mm	8'2"	2490 mm	8'2"
600 mm (24") Shoes	2590 mm	8'6"	2590 mm	8'6"
700 mm (28") Shoes (with steps)	2690 mm	8'10"	2690 mm	8'10"
790 mm (31") Shoes (with steps)	2870 mm	9'5"	2870 mm	9'5"
Bucket Type	GD		GD	
Bucket Capacity	1.00 m <sup>3</sup>	1.31 yd <sup>3</sup>	0.76 m <sup>3</sup>	0.99 yd <sup>3</sup>
Bucket Tip Radius	1390 mm	4'7"	1390 mm	4'7"

# 317 GC Hydraulic Excavator Specifications

## Working Ranges

All dimensions are approximate and may vary depending on bucket selection.

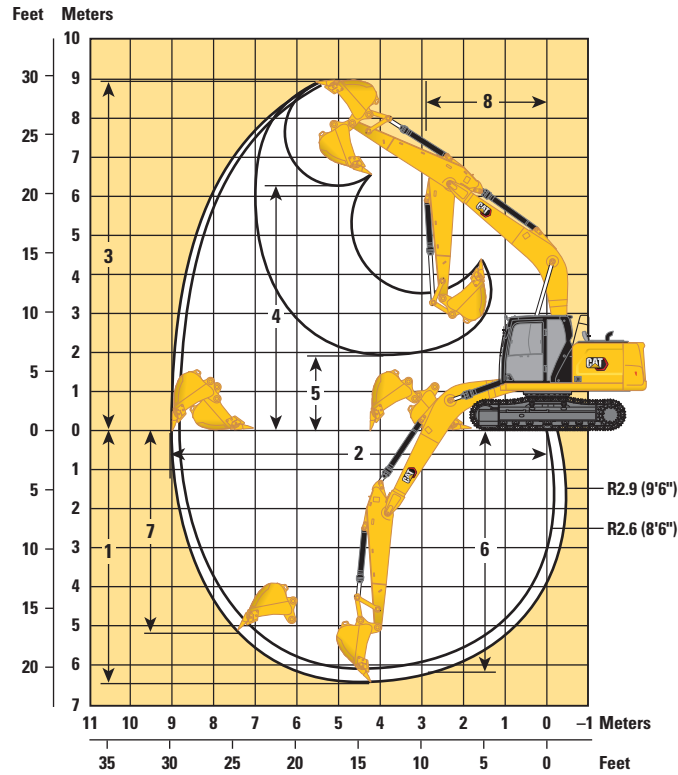

### Boom Option

**Reach Boom**  
5.1 m (16'9")

### Stick Options

**Reach Stick**  
R2.6 (8'6")

**Reach Stick**  
R2.9 (9'6")

	Reach Stick R2.6 (8'6")		Reach Stick R2.9 (9'6")	
1 Maximum Digging Depth	6100 mm	20'0"	6400 mm	21'0"
2 Maximum Reach at Ground Line	8790 mm	28'10"	9010 mm	29'7"
3 Maximum Cutting Height	8940 mm	29'4"	8900 mm	29'2"
4 Maximum Loading Height	6270 mm	20'7"	6280 mm	20'7"
5 Minimum Loading Height	2290 mm	7'6"	1990 mm	6'6"
6 Maximum Depth Cut for 2440 mm (8'0") Level Bottom	5880 mm	19'3"	6170 mm	20'3"
7 Maximum Vertical Wall Digging Depth	4980 mm	16'4"	4960 mm	16'3"
8 Minimum Working Equipment Radius	2980 mm	9'9"	2940 mm	9'8"
Bucket Digging Force (ISO)	123 kN	27,650 lbf	123 kN	27,650 lbf
Stick Digging Force (ISO)	80 kN	17,980 lbf	75 kN	16,860 lbf
Bucket Type	GD		GD	
Bucket Capacity	1.00 m <sup>3</sup>	1.31 yd <sup>3</sup>	0.76 m <sup>3</sup>	0.99 yd <sup>3</sup>
Bucket Tip Radius	1390 mm	4'7"	1390 mm	4'7"

# 317 GC Hydraulic Excavator Specifications

## Blade Working Ranges

All dimensions are approximate and may vary depending on bucket selection.

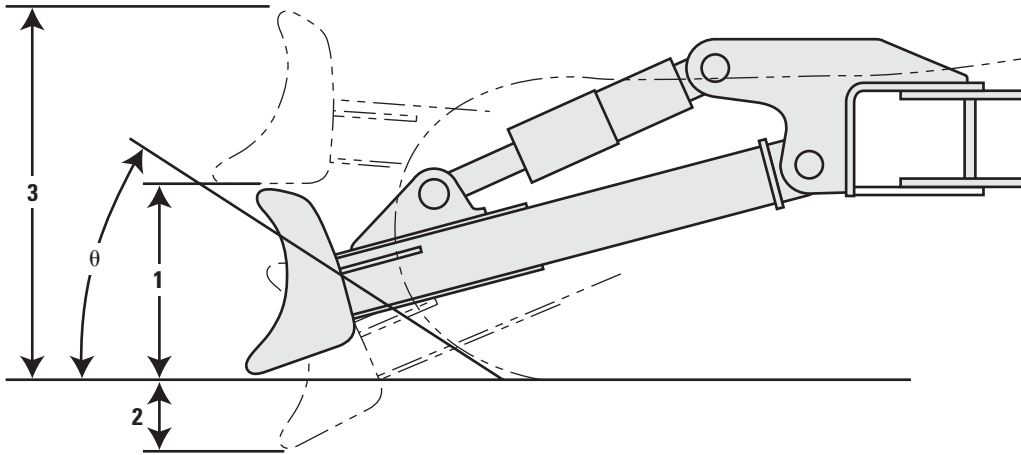

Blade Options	2500 mm (8'2")		2600 mm (8'6")		2700 mm (8'10")	
	<b>1</b> Blade Height	614 mm	2'0"	614 mm	2'0"	614 mm
<b>2</b> Maximum Lowering Depth from Ground	518 mm	1'8"	518 mm	1'8"	518 mm	1'8"
<b>3</b> Maximum Raising Height above Ground	976 mm	3'2"	976 mm	3'2"	976 mm	3'2"
<b><math>\theta</math></b> Approach Angle	23.5°		23.5°		23.5°	

# 317 GC Hydraulic Excavator Specifications

## Reach Boom Lift Capacities – Counterweight: 3.05 mt (6,720 lb) – without Bucket

2700 mm (8'10") Blade

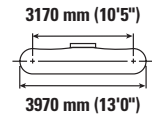
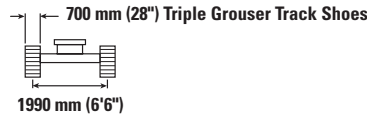
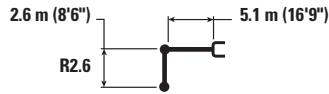

Reach Boom	Unit	1500 mm/5'0"		3000 mm/10'0"		4500 mm/15'0"		6000 mm/20'0"		7500 mm/25'0"		mm ft/in		
		kg lb	kg lb	kg lb	kg lb	kg lb	kg lb	kg lb	kg lb	kg lb	kg lb	kg lb	mm ft/in	
7500 mm 25'0"	kg lb					*7,700 *7,700						*3350 *7,450	*3350 *7,450	4770 15'01"
6000 mm 20'0"	kg lb							*3600 *6,650	3500 *6,650			*2950 *6,450	*2950 *6,450	6190 20'00"
4500 mm 15'0"	kg lb					*4650 *10,050	*4650 *10,050	*4300 *9,450	3500 7,500			*2850 *6,200	2750 6,050	7020 22'10"
3000 mm 10'0"	kg lb			*8900 *18,900	*8900 *18,900	*5900 *12,700	5100 11,000	*4850 *10,500	3350 7,250			*2900 *6,300	2450 5,350	7450 24'04"
1500 mm 5'0"	kg lb					*7250 *15,600	4800 10,300	4950 10,650	3200 6,950	*3500 2350		*3050 *6,750	2300 5,100	7560 24'09"
0 mm 0	kg lb			*6200 *14,200	*6200 *14,200	7400 15,950	4550 9,850	4800 10,350	3100 6,700			*3450 *7,600	2350 5,200	7370 24'02"
-1500 mm -5'0"	kg lb	*5650 *12,650	*5650 *12,650	*10 050 *22,950	8250 17,700	7350 15,750	4500 9,700	4750 10,250	3050 6,600			4000 8,750	2600 5,700	6850 22'04"
-3000 mm -10'0"	kg lb	*9900 *22,300	*9900 *22,300	*10 750 *23,250	8350 17,950	7400 15,900	4550 9,800					4950 11,000	3200 7,100	5900 19'02"
-4500 mm -15'0"	kg lb				*7750 *16,400							*5450 *11,900	5200 11,900	4240 13'06"

## Reach Boom Lift Capacities – Counterweight: 3.05 mt (6,720 lb) – without Bucket

2600 mm (8'6") Blade

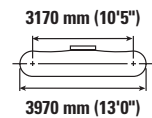
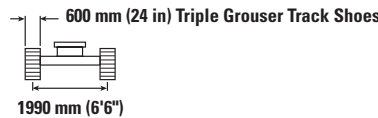

Reach Boom	Unit	1500 mm/5'0"		3000 mm/10'0"		4500 mm/15'0"		6000 mm/20'0"		7500 mm/25'0"		mm ft/in		
		kg lb	kg lb	kg lb	kg lb	kg lb	kg lb	kg lb	kg lb	kg lb	kg lb	kg lb	mm ft/in	
7500 mm 25'0"	kg lb					*7,700 *7,700						*3350 *7,450	*3350 *7,450	4770 15'01"
6000 mm 20'0"	kg lb							*3600 *6,650	3500 *6,650			*2950 *6,450	*2950 *6,450	6190 20'00"
4500 mm 15'0"	kg lb					*4650 *10,050	*4650 *10,050	*4300 *9,450	3450 7,450			*2850 *6,200	2700 5,950	7020 22'10"
3000 mm 10'0"	kg lb			*8900 *18,900	*8900 *18,900	*5900 *12,700	5050 10,900	*4850 *10,500	3350 7,150			*2900 *6,300	2400 5,250	7450 24'04"
1500 mm 5'0"	kg lb					*7250 *15,600	4700 10,150	4900 10,500	3200 6,850	*3500 2300		*3050 *6,750	2300 5,000	7560 24'09"
0 mm 0	kg lb			*6200 *14,200	*6200 *14,200	7350 15,750	4500 9,700	4750 10,200	3050 6,600			*3450 *7,600	2350 5,100	7370 24'02"
-1500 mm -5'0"	kg lb	*5650 *12,650	*5650 *12,650	*10 050 *22,950	8150 17,450	7250 15,550	4450 9,550	4700 10,100	3000 6,500			3950 8,650	2550 5,600	6850 22'04"
-3000 mm -10'0"	kg lb	*9900 *22,300	*9900 *22,300	*10 750 *23,250	8250 17,750	7300 15,700	4500 9,650					4900 10,850	3150 7,000	5900 19'02"
-4500 mm -15'0"	kg lb				*7750 *16,400							*5450 *11,900	5150 11,750	4240 13'06"



ISO 10567:2007



\* Indicates that the load is limited by hydraulic lifting capacity rather than tipping load. The above loads are in compliance with hydraulic excavator lift capacity standard ISO 10567:2007. They do not exceed 87% of hydraulic lifting capacity or 75% of tipping load. Weight of all lifting accessories must be deducted from the above lifting capacities. Lifting capacities are based on the machine standing on a firm, uniform supporting surface. The use of a work tool attachment point to handle/lift objects, could affect the machine lift performance.

Lift capacity stays with ±5% for all available track shoes.

Always refer to the appropriate Operation and Maintenance Manual for specific product information.

# 317 GC Hydraulic Excavator Specifications

## Reach Boom Lift Capacities – Counterweight: 3.05 mt (6,720 lb) – without Bucket

2500 mm (8'2") Blade

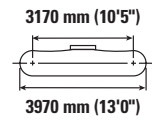
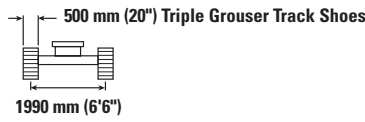
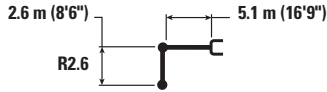

		1500 mm/5'0"		3000 mm/10'0"		4500 mm/15'0"		6000 mm/20'0"		7500 mm/25'0"		mm ft/in		
7500 mm 25'0"	kg lb				<b>*7,700</b>	<b>*7,700</b>						<b>*3350</b> <b>*7,450</b>	<b>*3350</b> <b>*7,450</b>	4770 15'01"
6000 mm 20'0"	kg lb						<b>*3600</b> <b>*6,650</b>	3450 <b>*6,650</b>				<b>*2950</b> <b>*6,450</b>	<b>*2950</b> <b>*6,450</b>	6190 20'00"
4500 mm 15'0"	kg lb				<b>*4650</b> <b>*10,050</b>	<b>*4650</b> <b>*10,050</b>	<b>*4300</b> <b>*9,450</b>	3400 <b>7,350</b>				<b>*2850</b> <b>*6,200</b>	2650 <b>5,900</b>	7020 22'10"
3000 mm 10'0"	kg lb			<b>*8900</b> <b>*18,900</b>	<b>*8900</b> <b>*18,900</b>	<b>*5900</b> <b>*12,700</b>	5000 <b>10,750</b>	<b>*4850</b> <b>*10,500</b>	3300 <b>7,050</b>			<b>*2900</b> <b>*6,300</b>	2350 <b>5,200</b>	7450 24'04"
1500 mm 5'0"	kg lb				<b>*7250</b> <b>*15,600</b>	4650 <b>10,050</b>	4850 <b>10,350</b>	3150 <b>6,750</b>	3450	2300		<b>*3050</b> <b>*6,750</b>	2250 <b>4,950</b>	7560 24'09"
0 mm 0	kg lb			<b>*6200</b> <b>*14,200</b>	<b>*6200</b> <b>*14,200</b>	7250 <b>15,550</b>	4450 <b>9,600</b>	4700 <b>10,100</b>	3050 <b>6,500</b>			<b>*3450</b> <b>*7,600</b>	2300 <b>5,050</b>	7370 24'02"
-1500 mm -5'0"	kg lb	<b>*5650</b> <b>*12,650</b>	<b>*5650</b> <b>*12,650</b>	<b>*10 050</b> <b>*22,950</b>	8050 <b>17,250</b>	7150 <b>15,350</b>	4400 <b>9,450</b>	4650 <b>10,000</b>	3000 <b>6,400</b>			3900 <b>8,550</b>	2550 <b>5,550</b>	6850 22'04"
-3000 mm -10'0"	kg lb	<b>*9900</b> <b>*22,300</b>	<b>*9900</b> <b>*22,300</b>	<b>*10 750</b> <b>*23,250</b>	8150 <b>17,500</b>	7200 <b>15,500</b>	4450 <b>9,550</b>					4850 <b>10,750</b>	3100 <b>6,900</b>	5900 19'02"
-4500 mm -15'0"	kg lb			<b>*7750</b> <b>*16,400</b>	<b>*7750</b> <b>*16,400</b>							<b>*5450</b> <b>*11,900</b>	5050 <b>11,600</b>	4240 13'06"

## Reach Boom Lift Capacities – Counterweight: 3.05 mt (6,720 lb) – without Bucket

2700 mm (8'10") Blade

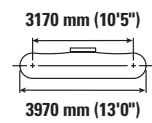
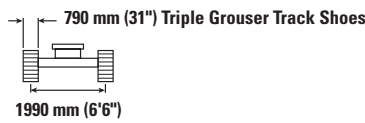
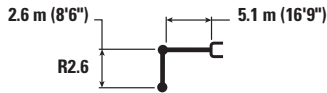

		1500 mm/5'0"		3000 mm/10'0"		4500 mm/15'0"		6000 mm/20'0"		7500 mm/25'0"		mm ft/in		
7500 mm 25'0"	kg lb				<b>*7,700</b>	<b>*7,700</b>						<b>*3350</b> <b>*7,450</b>	<b>*3350</b> <b>*7,450</b>	4770 15'01"
6000 mm 20'0"	kg lb						<b>*3600</b> <b>*6,650</b>	<b>*3600</b> <b>*6,650</b>				<b>*2950</b> <b>*6,450</b>	<b>*2950</b> <b>*6,450</b>	6190 20'00"
4500 mm 15'0"	kg lb				<b>*4650</b> <b>*10,050</b>	<b>*4650</b> <b>*10,050</b>	<b>*4300</b> <b>*9,450</b>	3550 <b>7,650</b>				<b>*2850</b> <b>*6,200</b>	2800 <b>6,150</b>	7020 22'10"
3000 mm 10'0"	kg lb			<b>*8900</b> <b>*18,900</b>	<b>*8900</b> <b>*18,900</b>	<b>*5900</b> <b>*12,700</b>	5200 <b>11,200</b>	<b>*4850</b> <b>*10,500</b>	3450 <b>7,400</b>			<b>*2900</b> <b>*6,300</b>	2500 <b>5,450</b>	7450 24'04"
1500 mm 5'0"	kg lb				<b>*7250</b> <b>*15,600</b>	4850 <b>10,500</b>	5050 <b>10,850</b>	3300 <b>7,050</b>	<b>*3500</b>	2400		<b>*3050</b> <b>*6,750</b>	2350 <b>5,200</b>	7560 24'09"
0 mm 0	kg lb			<b>*6200</b> <b>*14,200</b>	<b>*6200</b> <b>*14,200</b>	7600 <b>16,300</b>	4650 <b>10,050</b>	4950 <b>10,600</b>	3150 <b>6,800</b>			<b>*3450</b> <b>*7,600</b>	2400 <b>5,300</b>	7370 24'02"
-1500 mm -5'0"	kg lb	<b>*5650</b> <b>*12,650</b>	<b>*5650</b> <b>*12,650</b>	<b>*10 050</b> <b>*22,950</b>	8400 <b>18,050</b>	7500 <b>16,100</b>	4600 <b>9,900</b>	4850 <b>10,500</b>	3150 <b>6,750</b>			4050 <b>8,950</b>	2650 <b>5,800</b>	6850 22'04"
-3000 mm -10'0"	kg lb	<b>*9900</b> <b>*22,300</b>	<b>*9900</b> <b>*22,300</b>	<b>*10 750</b> <b>*23,250</b>	8550 <b>18,300</b>	<b>*7450</b> <b>*16,050</b>	4650 <b>10,000</b>					5050 <b>11,250</b>	3250 <b>7,250</b>	5900 19'02"
-4500 mm -15'0"	kg lb			<b>*7750</b> <b>*16,400</b>	<b>*7750</b> <b>*16,400</b>							<b>*5450</b> <b>*11,900</b>	5300 <b>*11,900</b>	4240 13'06"



ISO 10567:2007



\* Indicates that the load is limited by hydraulic lifting capacity rather than tipping load. The above loads are in compliance with hydraulic excavator lift capacity standard ISO 10567:2007. They do not exceed 87% of hydraulic lifting capacity or 75% of tipping load. Weight of all lifting accessories must be deducted from the above lifting capacities. Lifting capacities are based on the machine standing on a firm, uniform supporting surface. The use of a work tool attachment point to handle/lift objects, could affect the machine lift performance.

Lift capacity stays with ±5% for all available track shoes.

Always refer to the appropriate Operation and Maintenance Manual for specific product information.

# 317 GC Hydraulic Excavator Specifications

## Reach Boom Lift Capacities – Counterweight: 3.05 mt (6,720 lb) – without Bucket

2700 mm (8'10") Blade

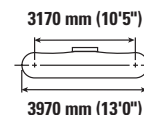
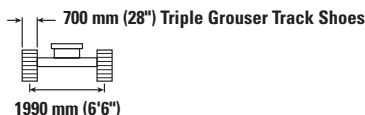

		1500 mm/5'0"		3000 mm/10'0"		4500 mm/15'0"		6000 mm/20'0"		7500 mm/25'0"		mm ft/in		
7500 mm 25'0"	kg lb											*2950 *6,600	*2950 *6,600	5100 16'02"
6000 mm 20'0"	kg lb							*3650 *7,450	3600 *7,450			*2650 *5,900	*2650 *5,900	6450 20'11"
4500 mm 15'0"	kg lb							*4050 *8,850	3500 7,550			*2600 *5,700	2600 *5,700	7240 23'07"
3000 mm 10'0"	kg lb			*8000 *17,050	*8000 *17,050	5550 *11,950	5150 11,100	*4600 *10,000	3350 7,250	*3350 *6,200	2400 5,100	*2700 *5,850	2300 5,100	7660 25'01"
1500 mm 5'0"	kg lb			*6950 *16,650	*6950 *16,650	*6950 *14,950	4800 10,300	4950 10,600	3200 6,900	3550 7,600	2350 5,000	*2900 *6,300	2200 4,850	7780 25'05"
0 mm 0	kg lb			*6950 *15,950	*6950 *15,950	7400 15,900	4550 9,800	4800 10,300	3100 6,600	3500 2250		*3250 *7,150	2250 4,900	7590 24'10"
-1500 mm -5'0"	kg lb	*5650 *12,550	*5650 *12,550	*10 000 *22,750	8150 17,450	7300 15,650	4450 9,600	4750 10,150	3000 6,500			3750 8,250	2450 5,350	7080 23'02"
-3000 mm -10'0"	kg lb	*9250 *20,750	*9250 *20,750	*11 150 *24,050	8250 17,700	7300 15,700	4500 9,650	4750 10,250	3050 6,600			4600 10,200	2950 6,550	6160 20'01"
-4500 mm -15'0"	kg lb			*8550 *18,200	8550 *18,200	*5750	4650					*5550 *12,200	4500 10,300	4610 14'09"

## Reach Boom Lift Capacities – Counterweight: 3.05 mt (6,720 lb) – without Bucket

2600 mm (8'6") Blade

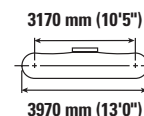
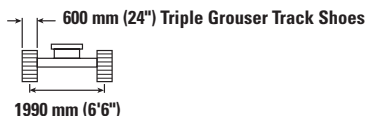

		1500 mm/5'0"		3000 mm/10'0"		4500 mm/15'0"		6000 mm/20'0"		7500 mm/25'0"		mm ft/in		
7500 mm 25'0"	kg lb											*2950 *6,600	*2950 *6,600	5100 16'02"
6000 mm 20'0"	kg lb							*3650 *7,450	3550 *7,450			*2650 *5,900	*2650 *5,900	6450 20'11"
4500 mm 15'0"	kg lb							*4050 *8,850	3450 7,450			*2600 *5,700	2550 5,650	7240 23'07"
3000 mm 10'0"	kg lb			*8000 *17,050	*8000 *17,050	*5550 *11,950	5100 10,950	*4600 *10,000	3350 7,150	*3350 *6,200	2350 5,050	*2700 *5,850	2300 5,000	7660 25'01"
1500 mm 5'0"	kg lb			*6950 *16,650	*6950 *16,650	*6950 *14,950	4750 10,200	4900 10,450	3150 6,800	3500 7,500	2300 4,900	*2900 *6,300	2200 4,750	7780 25'05"
0 mm 0	kg lb			*6950 *15,950	*6950 *15,950	7300 15,700	4500 9,650	4750 10,150	3050 6,550	3450	2250	*3250 *7,150	2200 4,850	7590 24'10"
-1500 mm -5'0"	kg lb	*5650 *12,550	*5650 *12,550	*10 000 *22,750	8050 17,250	7200 15,450	4400 9,450	4650 10,000	3000 6,400			3700 8,150	2400 5,300	7080 23'02"
-3000 mm -10'0"	kg lb	*9250 *20,750	*9250 *20,750	*11 150 *24,050	8150 17,450	7250 15,500	4400 9,500	4700 10,100	3000 6,500			4550 10,050	2900 6,450	6160 20'01"
-4500 mm -15'0"	kg lb			*8550 *18,200	8400 18,100	*5750	4600					*5550 *12,200	4450 10,150	4610 14'09"



ISO 10567:2007



\* Indicates that the load is limited by hydraulic lifting capacity rather than tipping load. The above loads are in compliance with hydraulic excavator lift capacity standard ISO 10567:2007. They do not exceed 87% of hydraulic lifting capacity or 75% of tipping load. Weight of all lifting accessories must be deducted from the above lifting capacities. Lifting capacities are based on the machine standing on a firm, uniform supporting surface. The use of a work tool attachment point to handle/lift objects, could affect the machine lift performance.

Lift capacity stays with ±5% for all available track shoes.

Always refer to the appropriate Operation and Maintenance Manual for specific product information.

# 317 GC Hydraulic Excavator Specifications

## Reach Boom Lift Capacities – Counterweight: 3.05 mt (6,720 lb) – without Bucket

2500 mm (8'2") Blade

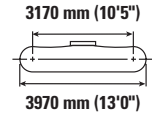
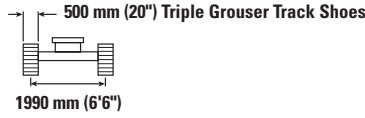
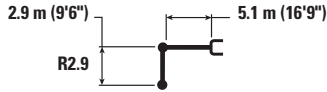

		1500 mm/5'0"		3000 mm/10'0"		4500 mm/15'0"		6000 mm/20'0"		7500 mm/25'0"		mm ft/in		
7500 mm 25'0"	kg lb											*2950 *6,600	*2950 *6,600	5100 16'02"
6000 mm 20'0"	kg lb							*3650 *7,450	3500 *7,450			*2650 *5,900	*2650 *5,900	6450 20'11"
4500 mm 15'0"	kg lb							*4050 *8,850	3450 7,350			*2600 *5,700	2550 5,600	7240 23'07"
3000 mm 10'0"	kg lb			*8000 *17,050	*8000 *17,050	*5550 *11,950	5050 10,850	*4600 *10,000	3300 7,050	*3350 *6,200	2350 5,000	*2700 *5,850	2250 4,950	7660 25'01"
1500 mm 5'0"	kg lb			*6950 *16,650	*6950 *16,650	*6950 *14,950	4650 10,050	4800 10,350	3150 6,700	3450 7,400	2250 4,850	*2900 *6,300	2150 4,700	7780 25'05"
0 mm 0	kg lb			*6950 *15,950	*6950 *15,950	7200 15,500	4450 9,550	4650 10,050	3000 6,450	3400	2200	*3250 *7,150	2200 4,750	7590 24'10"
-1500 mm -5'0"	kg lb	*5650 *12,550	*5650 *12,550	*10 000 *22,750	7950 17,000	7100 15,250	4350 9,350	4600 9,900	2950 6,300			3650 8,050	2350 5,200	7080 23'02"
-3000 mm -10'0"	kg lb	*9250 *20,750	*9250 *20,750	*11 150 *24,050	8050 17,250	7150 15,300	4350 9,400	4650 10,000	2950 6,400			4450 9,950	2900 6,350	6160 20'01"
-4500 mm -15'0"	kg lb			*8550 *18,200	8300 17,900	*5750	4550					*5550 *12,200	4400 10,000	4610 14'09"

## Reach Boom Lift Capacities – Counterweight: 3.05 mt (6,720 lb) – without Bucket

2700 mm (8'10") Blade

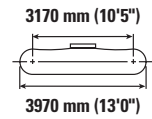
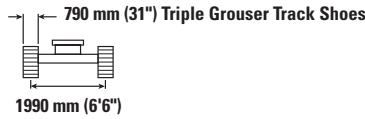
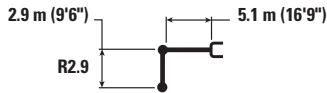

		1500 mm/5'0"		3000 mm/10'0"		4500 mm/15'0"		6000 mm/20'0"		7500 mm/25'0"		mm ft/in		
7500 mm 25'0"	kg lb											*2950 *6,600	*2950 *6,600	5100 16'02"
6000 mm 20'0"	kg lb							*3650 *7,450	3650 *7,450			*2650 *5,900	*2650 *5,900	6450 20'11"
4500 mm 15'0"	kg lb							*4050 *8,850	3600 7,700			*2600 *5,700	*2600 *5,700	7240 23'07"
3000 mm 10'0"	kg lb			*8000 *17,050	*8000 *17,050	*5550 *11,950	5250 11,300	*4600 *10,000	3450 7,400	*3350 *6,200	2450 5,250	*2700 *5,850	2350 5,200	7660 25'01"
1500 mm 5'0"	kg lb			*6950 *16,650	*6950 *16,650	*6950 *14,950	10,500	5050 10,850	3250 7,050	3600 7,750	2400 5,100	*2900 *6,300	2250 4,950	7780 25'05"
0 mm 0	kg lb			*6950 *15,950	*6950 *15,950	7550 16,250	4650 10,000	4900 10,550	3150 6,750	3550	2300	*3250 *7,150	2300 5,000	7590 24'10"
-1500 mm -5'0"	kg lb	*5650 *12,550	*5650 *12,550	*10 000 *22,750	8300 17,800	7450 16,000	4550 9,800	4850 10,400	3100 6,650			3850 8,450	2500 5,450	7080 23'02"
-3000 mm -10'0"	kg lb	*9250 *20,750	*9250 *20,750	*11 150 *24,050	8400 18,050	7500 16,050	4550 9,850	4850 10,450	3100 6,700			4700 10,400	3000 6,700	6160 20'01"
-4500 mm -15'0"	kg lb			*8550 *18,200	*8550 *18,200	*5750	4750					*5550 *12,200	4600 10,500	4610 14'09"



ISO 10567:2007



\* Indicates that the load is limited by hydraulic lifting capacity rather than tipping load. The above loads are in compliance with hydraulic excavator lift capacity standard ISO 10567:2007. They do not exceed 87% of hydraulic lifting capacity or 75% of tipping load. Weight of all lifting accessories must be deducted from the above lifting capacities. Lifting capacities are based on the machine standing on a firm, uniform supporting surface. The use of a work tool attachment point to handle/lift objects, could affect the machine lift performance.

Lift capacity stays with ±5% for all available track shoes.

Always refer to the appropriate Operation and Maintenance Manual for specific product information.

# 317 GC Hydraulic Excavator Specifications

## Reach Boom Lift Capacities – Counterweight: 3.05 mt (6,720 lb) – without Bucket

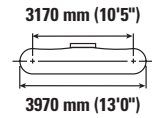
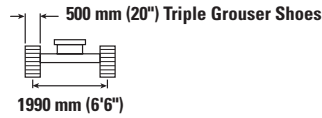
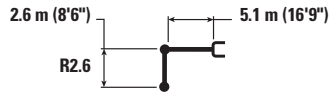

Reach Boom	1500 mm/5'0"		3000 mm/10'0"		4500 mm/15'0"		6000 mm/20'0"		7500 mm/25'0"		mm ft/in		
	kg lb	kg lb	kg lb	kg lb	kg lb	kg lb	kg lb	kg lb	kg lb	kg lb	kg lb	mm ft/in	
7500 mm 25'0"					*7,700	*7,700					*3350 *7,450	*3350 *7,450	4770 15'1"
6000 mm 20'0"							*3600 *6,650	3350 *6,650			*2950 *6,450	*2950 *6,450	6190 20'0"
4500 mm 15'0"					*4650 *10,050	*4650 *10,050	*4300 *9,450	3300 7,050			*2850 *6,200	2550 5,600	7020 22'10"
3000 mm 10'0"			*8900 *18,900	8750 *18,900	*5900 *12,700	4800 10,300	*4850 *10,500	3150 6,750			*2900 *6,300	2250 4,950	7450 24'4"
1500 mm 5'0"					*7250 *15,600	4450 9,600	4850 10,400	3000 6,450	*3500	2200	*3050 *6,750	2150 4,700	7560 24'9"
0 mm 0			*6200 *14,200	*6200 *14,200	7300 15,600	4250 9,150	4700 10,150	2900 6,200			*3450 *7,600	2200 4,800	7370 24'2"
-1500 mm -5'0"	kg lb	*5650 *12,650	*5650 *12,650	*10 050 *22,950	7650 16,450	7200 15,450	4200 9,000	4650 10,050	2850 6,100		3900 8,600	2400 5,300	6850 22'4"
-3000 mm -10'0"	kg lb	*9900 *22,300	*9900 *22,300	*10 750 *23,250	7800 16,750	7250 15,550	4250 9,100				4850 10,800	2950 6,600	5900 19'2"
-4500 mm -15'0"	kg lb			*7750 *16,400							*5450 *11,900	4850 11,100	4240 13'6"

## Reach Boom Lift Capacities – Counterweight: 3.05 mt (6,720 lb) – without Bucket

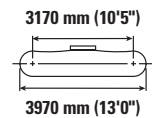
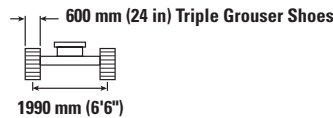

Reach Boom	1500 mm/5'0"		3000 mm/10'0"		4500 mm/15'0"		6000 mm/20'0"		7500 mm/25'0"		mm ft/in		
	kg lb	kg lb	kg lb	kg lb	kg lb	kg lb	kg lb	kg lb	kg lb	kg lb	kg lb	mm ft/in	
7500 mm 25'0"					*7,700	*7,700					*3350 *7,450	*3350 *7,450	4770 15'1"
6000 mm 20'0"							*3600 *6,650	3350 *6,650			*2950 *6,450	*2950 *6,450	6190 20'0"
4500 mm 15'0"					*4650 *10,050	*4650 *10,050	*4300 *9,450	3300 7,100			*2850 *6,200	2550 5,700	7020 22'10"
3000 mm 10'0"			*8900 *18,900	8850 *18,900	*5900 *12,700	4850 10,450	*4850 *10,500	3200 6,850			*2900 *6,300	2300 5,050	7450 24'4"
1500 mm 5'0"					*7250 *15,600	4500 9,700	4900 10,550	3050 6,500	*3500	2200	*3050 *6,750	2200 4,800	7560 24'9"
0 mm 0			*6200 *14,200	*6200 *14,200	7350 15,800	4300 9,250	4800 10,300	2900 6,300			*3450 *7,600	2200 4,850	7370 24'2"
-1500 mm -5'0"	kg lb	*5650 *12,650	*5650 *12,650	*10 050 *22,950	7750 16,650	7300 15,650	4250 9,100	4750 10,150	2900 6,200		3950 8,700	2450 5,350	6850 22'4"
-3000 mm -10'0"	kg lb	*9900 *22,300	*9900 *22,300	*10 750 *23,250	7900 16,950	7350 15,750	4300 9,200				4900 10,950	3000 6,650	5900 19'2"
-4500 mm -15'0"	kg lb			*7750 *16,400							*5450 *11,900	4900 11,250	4240 13'6"



ISO 10567:2007



\* Indicates that the load is limited by hydraulic lifting capacity rather than tipping load. The above loads are in compliance with hydraulic excavator lift capacity standard ISO 10567:2007. They do not exceed 87% of hydraulic lifting capacity or 75% of tipping load. Weight of all lifting accessories must be deducted from the above lifting capacities. Lifting capacities are based on the machine standing on a firm, uniform supporting surface. The use of a work tool attachment point to handle/lift objects, could affect the machine lift performance.

Lift capacity stays with ±5% for all available track shoes.

Always refer to the appropriate Operation and Maintenance Manual for specific product information.

# 317 GC Hydraulic Excavator Specifications

## Reach Boom Lift Capacities – Counterweight: 3.05 mt (6,720 lb) – without Bucket

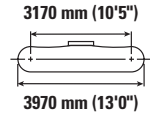
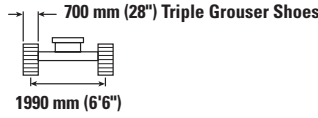
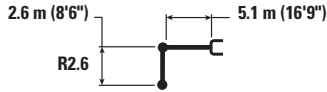

Reach	Unit	1500 mm/5'0"		3000 mm/10'0"		4500 mm/15'0"		6000 mm/20'0"		7500 mm/25'0"		mm ft/in		
		kg lb	kg lb	kg lb	kg lb	kg lb	kg lb	kg lb	kg lb	kg lb	kg lb	kg lb	mm ft/in	
7500 mm 25'0"	kg lb					*7,700 *7,700						*3350 *7,450	*3350 *7,450	4770 15'1"
6000 mm 20'0"	kg lb							*3600 *6,650	3400 *6,650			*2950 *6,450	*2950 *6,450	6190 20'0"
4500 mm 15'0"	kg lb					*4650 *10,050	*4650 *10,050	*4300 *9,450	3350 7,200			*2850 *6,200	2600 5,750	7020 22'10"
3000 mm 10'0"	kg lb			*8900 *18,900	*8900 *18,900	*5900 *12,700	4900 10,550	*4850 *10,500	3250 6,950			*2900 *6,300	2300 5,100	7450 24'4"
1500 mm 5'0"	kg lb					*7250 *15,600	4550 9,850	4950 10,700	3100 6,600	*3500 2250		*3050 *6,750	2200 4,850	7560 24'9"
0 mm 0	kg lb			*6200 *14,200	*6200 *14,200	7450 16,000	4350 9,400	4850 10,400	2950 6,350			*3450 *7,600	2250 4,950	7370 24'2"
-1500 mm -5'0"	kg lb	*5650 *12,650	*5650 *12,650	*10 050 *22,950	7850 16,850	7400 15,850	4300 9,250	4800 10,300	2900 6,250			4000 8,800	2450 5,400	6850 22'4"
-3000 mm -10'0"	kg lb	*9900 *22,300	*9900 *22,300	*10 750 *23,250	8000 17,150	7450 15,950	4350 9,350					5000 11,100	3050 6,750	5900 19'2"
-4500 mm -15'0"	kg lb											*5450 *11,900	4950 11,350	4240 13'6"

## Reach Boom Lift Capacities – Counterweight: 3.05 mt (6,720 lb) – without Bucket

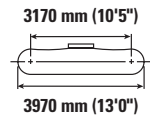
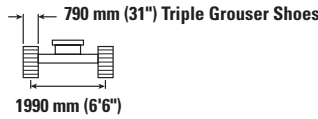
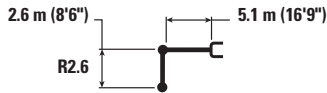

Reach	Unit	1500 mm/5'0"		3000 mm/10'0"		4500 mm/15'0"		6000 mm/20'0"		7500 mm/25'0"		mm ft/in		
		kg lb	kg lb	kg lb	kg lb	kg lb	kg lb	kg lb	kg lb	kg lb	kg lb	kg lb	mm ft/in	
7500 mm 25'0"	kg lb					*7,700 *7,700						*3350 *7,450	*3350 *7,450	4770 15'1"
6000 mm 20'0"	kg lb							*3600 *6,650	3450 *6,650			*2950 *6,450	*2950 *6,450	6190 20'0"
4500 mm 15'0"	kg lb					*4650 *10,050	*4650 *10,050	*4300 *9,450	3400 7,350			*2850 *6,200	2650 5,900	7020 22'10"
3000 mm 10'0"	kg lb			*8900 *18,900	*8900 *18,900	*5900 *12,700	5000 10,750	*4850 *10,500	3300 7,050			*2900 *6,300	2350 5,200	7450 24'4"
1500 mm 5'0"	kg lb					*7250 *15,600	4650 10,050	5100 10,900	3150 6,750	*3500 2300		*3050 *6,750	2250 4,950	7560 24'9"
0 mm 0	kg lb			*6200 *14,200	*6200 *14,200	7650 16,350	4450 9,600	4950 10,650	3050 6,500			*3450 *7,600	2300 5,050	7370 24'2"
-1500 mm -5'0"	kg lb	*5650 *12,650	*5650 *12,650	*10 050 *22,950	8050 17,200	7550 16,200	4400 9,450	4900 10,550	3000 6,400			4100 9,000	2500 5,550	6850 22'4"
-3000 mm -10'0"	kg lb	*9900 *22,300	*9900 *22,300	*10 750 *23,250	8150 17,500	*7450 *16,050	4450 9,550					5100 11,300	3100 6,900	5900 19'2"
-4500 mm -15'0"	kg lb											*5450 *11,900	5050 11,600	4240 13'6"



ISO 10567:2007



\* Indicates that the load is limited by hydraulic lifting capacity rather than tipping load. The above loads are in compliance with hydraulic excavator lift capacity standard ISO 10567:2007. They do not exceed 87% of hydraulic lifting capacity or 75% of tipping load. Weight of all lifting accessories must be deducted from the above lifting capacities. Lifting capacities are based on the machine standing on a firm, uniform supporting surface. The use of a work tool attachment point to handle/lift objects, could affect the machine lift performance.

Lift capacity stays with ±5% for all available track shoes.

Always refer to the appropriate Operation and Maintenance Manual for specific product information.

# 317 GC Hydraulic Excavator Specifications

## Reach Boom Lift Capacities – Counterweight: 3.05 mt (6,720 lb) – without Bucket

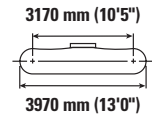
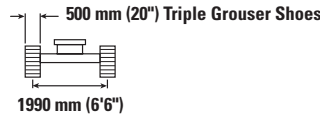
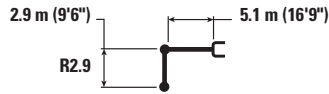

Reach	Unit	1500 mm/5'0"		3000 mm/10'0"		4500 mm/15'0"		6000 mm/20'0"		7500 mm/25'0"		mm ft/in		
		kg lb	kg lb	kg lb	kg lb	kg lb	kg lb	kg lb	kg lb	kg lb	kg lb	kg lb	mm ft/in	
7500 mm 25'0"	kg lb											*2950 *6,600	*2950 *6,600	5100 16'2"
6000 mm 20'0"	kg lb							*3650 *7,450	3350 7,150			*2650 *5,900	*2650 *5,900	6450 20'11"
4500 mm 15'0"	kg lb							*4050 *8,850	3300 7,050			*2600 *5,700	2400 5,350	7240 23'7"
3000 mm 10'0"	kg lb			*8000 *17,050	*8000 *17,050	*5550 *11,950	4800 10,400	*4600 *10,000	3150 6,750	*3350 *6,200	2250 4,750	*2700 *5,850	2150 4,700	7660 25'1"
1500 mm 5'0"	kg lb			*6950 *16,650	*6950 *16,650	*6950 *14,950	4450 9,600	4850 10,400	3000 6,400	3450 7,450	2150 4,600	*2900 *6,300	2050 4,500	7780 25'5"
0 mm 0	kg lb			*6950 *15,950	*6950 *15,950	7250 15,550	4250 9,100	4700 10,100	2850 6,150	3400 2100		*3250 *7,150	2050 4,550	7590 24'10"
-1500 mm -5'0"	kg lb	*5650 *12,550	*5650 *12,550	*10 000 *22,750	7550 16,250	7150 15,350	4150 8,900	4650 9,950	2800 6,000			3700 8,100	2250 4,950	7080 23'2"
-3000 mm -10'0"	kg lb	*9250 *20,750	*9250 *20,750	*11 150 *24,050	7700 16,450	7150 15,400	4150 8,950	4650 10,050	2850 6,100			4500 10,000	2750 6,050	6160 20'1"
-4500 mm -15'0"	kg lb			*8550 *18,200	7950 17,100	*5750	4350					*5550 *12,200	4200 9,550	4610 14'9"

## Reach Boom Lift Capacities – Counterweight: 3.05 mt (6,720 lb) – without Bucket

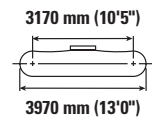
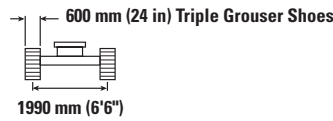

Reach	Unit	1500 mm/5'0"		3000 mm/10'0"		4500 mm/15'0"		6000 mm/20'0"		7500 mm/25'0"		mm ft/in		
		kg lb	kg lb	kg lb	kg lb	kg lb	kg lb	kg lb	kg lb	kg lb	kg lb	kg lb	mm ft/in	
7500 mm 25'0"	kg lb											*2950 *6,600	*2950 *6,600	5100 16'2"
6000 mm 20'0"	kg lb							*3650 *7,450	3400 7,250			*2650 *5,900	*2650 *5,900	6450 20'11"
4500 mm 15'0"	kg lb							*4050 *8,850	3350 7,150			*2600 *5,700	2450 5,400	7240 23'7"
3000 mm 10'0"	kg lb			*8000 *17,050	*8000 *17,050	*5550 *11,950	4900 10,500	*4600 *10,000	3200 6,850	*3350 *6,200	2250 4,800	*2700 *5,850	2200 4,800	7660 25'1"
1500 mm 5'0"	kg lb			*6950 *16,650	*6950 *16,650	*6950 *14,950	4500 9,750	4900 10,550	3000 6,500	3500 7,550	2200 4,700	*2900 *6,300	2050 4,550	7780 25'5"
0 mm 0	kg lb			*6950 *15,950	*6950 *15,950	7350 15,750	4300 9,200	4750 10,200	2900 6,200	3450 2150		*3250 *7,150	2100 4,600	7590 24'10"
-1500 mm -5'0"	kg lb	*5650 *12,550	*5650 *12,550	*10 000 *22,750	7650 16,450	7250 15,500	4200 9,000	4700 10,100	2850 6,100			3750 8,200	2300 5,000	7080 23'2"
-3000 mm -10'0"	kg lb	*9250 *20,750	*9250 *20,750	*11 150 *24,050	7750 16,700	7250 15,600	4200 9,050	4700 10,150	2850 6,150			4550 10,100	2750 6,150	6160 20'1"
-4500 mm -15'0"	kg lb			*8550 *18,200	8050 17,300	*5750	4400					*5550 *12,200	4250 9,700	4610 14'9"



ISO 10567:2007



\* Indicates that the load is limited by hydraulic lifting capacity rather than tipping load. The above loads are in compliance with hydraulic excavator lift capacity standard ISO 10567:2007. They do not exceed 87% of hydraulic lifting capacity or 75% of tipping load. Weight of all lifting accessories must be deducted from the above lifting capacities. Lifting capacities are based on the machine standing on a firm, uniform supporting surface. The use of a work tool attachment point to handle/lift objects, could affect the machine lift performance.

Lift capacity stays with ±5% for all available track shoes.

Always refer to the appropriate Operation and Maintenance Manual for specific product information.

# 317 GC Hydraulic Excavator Specifications

## Reach Boom Lift Capacities – Counterweight: 3.05 mt (6,720 lb) – without Bucket

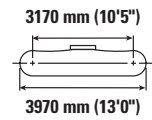
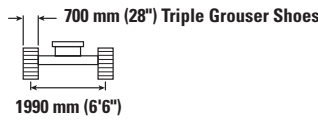
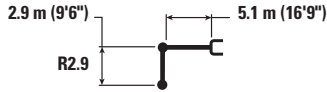

		1500 mm/5'0"		3000 mm/10'0"		4500 mm/15'0"		6000 mm/20'0"		7500 mm/25'0"		mm ft/in		
7500 mm 25'0"	kg lb											*2950 *6,600	*2950 *6,600	5100 16'2"
6000 mm 20'0"	kg lb							*3650 *7,450	3450 7,350			*2650 *5,900	*2650 *5,900	6450 20'11"
4500 mm 15'0"	kg lb							*4050 *8,850	3350 7,200			*2600 *5,700	2450 5,450	7240 23'7"
3000 mm 10'0"	kg lb			*8000 *17,050	*8000 *17,050	*5550 *11,950	4950 10,600	*4600 *10,000	3250 6,950	*3350 *6,200	2300 4,900	*2700 *5,850	2200 4,850	7660 25'1"
1500 mm 5'0"	kg lb			*6950 *16,650	*6950 *16,650	*6950 *14,950	4600 9,850	4950 10,650	3050 6,600	3550 7,650	2200 4,750	*2900 *6,300	2100 4,600	7780 25'5"
0 mm 0	kg lb			*6950 *15,950	*6950 *15,950	7450 16,000	4350 9,350	4800 10,350	2950 6,300	3500	2150	*3250 *7,150	2150 4,650	7590 24'10"
-1500 mm -5'0"	kg lb	*5650 *12,550	*5650 *12,550	*10 000 *22,750	7750 16,650	7350 15,750	4250 9,100	4750 10,200	2850 6,150			3800 8,300	2300 5,100	7080 23'2"
-3000 mm -10'0"	kg lb	*9250 *20,750	*9250 *20,750	*11 150 *24,050	7850 16,900	7350 15,800	4250 9,200	4800 10,300	2900 6,250			4600 10,250	2800 6,200	6160 20'1"
-4500 mm -15'0"	kg lb			*8550 *18,200	8150 17,500	*5750	4450					*5550 *12,200	4300 9,800	4610 14'9"

## Reach Boom Lift Capacities – Counterweight: 3.05 mt (6,720 lb) – without Bucket

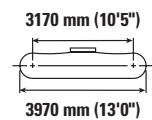
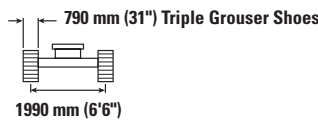
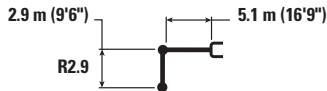

		1500 mm/5'0"		3000 mm/10'0"		4500 mm/15'0"		6000 mm/20'0"		7500 mm/25'0"		mm ft/in		
7500 mm 25'0"	kg lb											*2950 *6,600	*2950 *6,600	5100 16'2"
6000 mm 20'0"	kg lb							*3650 *7,450	3500 *7,450			*2650 *5,900	*2650 *5,900	6450 20'11"
4500 mm 15'0"	kg lb							*4050 *8,850	3450 7,350			*2600 *5,700	2500 5,600	7240 23'7"
3000 mm 10'0"	kg lb			*8000 *17,050	*8000 *17,050	*5550 *11,950	5050 10,800	*4600 *10,000	3300 7,050	*3350 *6,200	2350 5,000	*2700 *5,850	2250 4,950	7660 25'1"
1500 mm 5'0"	kg lb			*6950 *16,650	*6950 *16,650	*6950 *14,950	4650 10,050	5050 10,900	3150 6,700	3650 7,800	2250 4,850	*2900 *6,300	2150 4,700	7780 25'5"
0 mm 0	kg lb			*6950 *15,950	*6950 *15,950	7600 16,300	4450 9,550	4950 10,600	3000 6,450	3600	2200	*3250 *7,150	2200 4,750	7590 24'10"
-1500 mm -5'0"	kg lb	*5650 *12,550	*5650 *12,550	*10 000 *22,750	7950 17,000	7500 16,100	4350 9,300	4850 10,450	2950 6,300			3850 8,500	2350 5,200	7080 23'2"
-3000 mm -10'0"	kg lb	*9250 *20,750	*9250 *20,750	*11 150 *24,050	8050 17,250	7500 16,150	4350 9,400	4900 10,550	2950 6,400			4700 10,450	2850 6,350	6160 20'1"
-4500 mm -15'0"	kg lb			*8550 *18,200	8300 17,850	*5750	4550					*5550 *12,200	4400 10,000	4610 14'9"



ISO 10567:2007



\* Indicates that the load is limited by hydraulic lifting capacity rather than tipping load. The above loads are in compliance with hydraulic excavator lift capacity standard ISO 10567:2007. They do not exceed 87% of hydraulic lifting capacity or 75% of tipping load. Weight of all lifting accessories must be deducted from the above lifting capacities. Lifting capacities are based on the machine standing on a firm, uniform supporting surface. The use of a work tool attachment point to handle/lift objects, could affect the machine lift performance.

Lift capacity stays with ±5% for all available track shoes.

Always refer to the appropriate Operation and Maintenance Manual for specific product information.

# 317 GC Hydraulic Excavator Specifications

## Bucket Specifications and Compatibility

	Linkage	Width		Capacity		Weight		Fill %	Reach Boom		
		mm	in	m <sup>3</sup>	yd <sup>3</sup>	kg	lb		R2.6 (8'6")	R2.9 m (9'6")	
<b>Pin-On (No Quick Coupler)</b>											
General Duty	316	600	24	0.35	0.46	440	969	100	●	●	
	316	900	36	0.62	0.81	546	1,203	100	●	●	
	316	1200	48	0.91	1.19	658	1,450	100	⊖	⊖	
	316	1300	51	1.00	1.31	695	1,532	100	⊖	○	
Ditch Cleaning	316	2000	78	0.94	1.23	723	1,594	100	⊖	⊖	
Ditch Cleaning – Tilt	316	2000	79	0.86	1.12	1028	2,266	100	○	○	
Maximum load with pin-on (payload + bucket)								kg	2200	2080	
								lb	4,842	4,583	
<b>With Cat Pin Grabber Coupler</b>											
General Duty	316	600	24	0.35	0.46	440	969	100	●	●	
	316	900	36	0.62	0.81	546	1,203	100	●	●	
	316	1200	48	0.91	1.19	658	1,450	100	○	○	
	316	1300	51	1.00	1.31	695	1,532	100	○	○	
Ditch Cleaning	316	2000	78	0.94	1.23	723	1,594	100	○	○	
Ditch Cleaning – Tilt	316	2000	79	0.86	1.12	1028	2,266	100	◇	◇	
Maximum load with coupler (payload + bucket)								kg	1896	1879	
								lb	4,180	4,142	

The above loads are in compliance with hydraulic excavator standard EN474-5:2006+A3:2013, they do not exceed 87% of hydraulic lifting capacity or 75% of tipping capacity with front linkage fully extended at ground line with bucket curled.  
Capacity based on ISO 7451:2007.

### Maximum Material Density:

- 2100 kg/m<sup>3</sup> (3,500 lb/yd<sup>3</sup>)
- ⊖ 1500 kg/m<sup>3</sup> (2,500 lb/yd<sup>3</sup>)
- 1200 kg/m<sup>3</sup> (2,000 lb/yd<sup>3</sup>)
- ◇ 900 kg/m<sup>3</sup> (1,500 lb/yd<sup>3</sup>)

Caterpillar recommends using appropriate work tools to maximize the value customers receive from our products. Use of work tools, including buckets, which are outside of Caterpillar's recommendations or specifications for weight, dimensions, flows, pressures, etc. may result in less-than-optimal performance, including but not limited to reductions in production, stability, reliability, and component durability. Improper use of a work tool resulting in sweeping, prying, twisting and/or catching of heavy loads will reduce the life of the boom and stick.

(continued on next page)

# 317 GC Hydraulic Excavator Specifications

## Bucket Specifications and Compatibility (continued)

	Linkage	Width		Capacity		Weight		Fill %	Reach Boom	
		mm	in	m <sup>3</sup>	yd <sup>3</sup>	kg	lb		R2.6 (8'6")	R2.9 m (9'6")
<b>With CW30 Coupler</b>										
General Duty	316	600	24	0.35	0.46	439	967	100	●	●
	316	750	30	0.49	0.64	475	1,047	100	●	●
	316	900	36	0.62	0.81	534	1,177	100	●	●
	316	1100	43	0.80	1.04	593	1,307	100	⊙	⊖
	316	1200	48	0.90	1.18	646	1,423	100	⊖	○
	316	1300	51	1.00	1.31	677	1,492	100	○	○
Heavy Duty	316	1300	51	1.00	1.31	694	1,529	100	○	○
General Duty – Leveling Edge	316	996	39.2	0.70	0.93	586	1,291	100	⊙	⊙
	316	1200	47	0.91	1.19	672	1,481	100	⊖	○
	316	690	27	0.47	0.61	476	1,049	100	●	●
	316	790	31	0.56	0.73	509	1,122	100	●	●
	316	1400	55	1.09	1.43	738	1,626	100	◇	◇
Ditch Cleaning	316	1800	72	1.10	1.44	646	1,423	100	○	◇
	316	1800	72	1.24	1.62	678	1,496	100	◇	◇
	316	2100	82	1.45	1.90	760	1,675	100	X	X
Ditch Cleaning – Tilt	316	1800	72	0.78	1.02	1048	2,310	100	○	◇
	316	2000	79	0.86	1.13	1111	2,449	100	◇	◇
Maximum load with coupler (payload + bucket)								kg	1978	1861
								lb	4,361	4,102
<b>With CW30S Coupler</b>										
General Duty	316	600	24	0.35	0.46	423	932	100	●	●
	316	750	30	0.49	0.64	471	1,038	100	●	●
	316	900	36	0.62	0.81	534	1,177	100	●	●
	316	1100	43	0.80	1.04	593	1,307	100	⊙	⊖
	316	1200	48	0.91	1.18	646	1,423	100	⊖	○
	316	1300	51	1.00	1.31	677	1,492	100	○	○
	316	1400	55	1.09	1.43	707	1,558	100	○	◇
Heavy Duty	316	1200	48	0.91	1.18	663	1,461	100	⊖	○
	316	1300	51	1.00	1.31	695	1,531	100	○	○
Ditch Cleaning – Tilt	316	2000	79	0.86	1.13	1092	2,407	100	◇	◇
Maximum load with coupler (payload + bucket)								kg	2013	1896
								lb	4,438	4,179

The above loads are in compliance with hydraulic excavator standard EN474-5:2006+A3:2013, they do not exceed 87% of hydraulic lifting capacity or 75% of tipping capacity with front linkage fully extended at ground line with bucket curled.

Capacity based on ISO 7451:2007.

### Maximum Material Density:

- 2100 kg/m<sup>3</sup> (3,500 lb/yd<sup>3</sup>)
- ⊙ 1800 kg/m<sup>3</sup> (3,000 lb/yd<sup>3</sup>)
- ⊖ 1500 kg/m<sup>3</sup> (2,500 lb/yd<sup>3</sup>)
- 1200 kg/m<sup>3</sup> (2,000 lb/yd<sup>3</sup>)
- ◇ 900 kg/m<sup>3</sup> (1,500 lb/yd<sup>3</sup>)
- X Not Recommended

Caterpillar recommends using appropriate work tools to maximize the value customers receive from our products. Use of work tools, including buckets, which are outside of Caterpillar's recommendations or specifications for weight, dimensions, flows, pressures, etc. may result in less-than-optimal performance, including but not limited to reductions in production, stability, reliability, and component durability. Improper use of a work tool resulting in sweeping, prying, twisting and/or catching of heavy loads will reduce the life of the boom and stick.

# 317 GC Hydraulic Excavator Specifications

## Attachments Offering Guide

Not all Attachments are available in all regions. Consult your Cat dealer for configurations available in your region.

Match    
  No Match    
  \* Working range front only    
  1800 kg/m<sup>3</sup> (3,000 lb/yd<sup>3</sup>)    
  1200 kg/m<sup>3</sup> (2,000 lb/yd<sup>3</sup>)    
  600 kg/m<sup>3</sup> (1,000 lb/yd<sup>3</sup>)

### PIN-ON ATTACHMENTS

Boom Type	Stick Length	Reach Boom	
		R2.6 (8'6")	R2.9 (9'6")
Hydraulic Hammers	H110 S	✓	✓
	H115 GC S	✓	✓
	H115 S	✓	✓
	H120 S	✓	✓
Demolition and Sorting Grapples	G313 GC	✓	✓
	G314	✓	✓
	G317 GC	✓	✓*
Mobile Scrap and Demolition Shears	S3015 Flat Top	✓	✓
Pulverizers	P214 Secondary Pulverizer	✓	✓
Compactors (Vibratory Plate)	CVP75	✓	✓
Rotary Cutters	RC15	✓	✓
Orange Peel Grapples	GSH420-500	●	○
	GSH420-600	○	○
	GSH420-750	○	
	GSH520-500	○	○
	GSH520-600	○	
	GSV420-400	●	●
	GSV420-500	●	●
	GSV420-600	○	○
	GSV420-750	○	
	GSV420-1250	◇	◇
	GSV520 GC-400	●	●
	GSV520 GC-500	●	○
	GSV520 GC-600	○	○
	GSV520 GC-1250	◇	
	GSV520-400	●	●
	GSV520-500	○	○
	GSV520-600	○	○

(continued on next page)

# 317 GC Hydraulic Excavator Specifications

## Attachments Offering Guide *(continued)*

Not all Attachments are available in all regions. Consult your Cat dealer for configurations available in your region.

Match       \* Working range front only       No Match

### CAT PIN GRABBER COUPLER ATTACHMENTS

Boom Type	Stick Length	Reach Boom	
		R2.6 (8'6")	R2.9 (9'6")
Hydraulic Hammers	H110 S	✓	✓
	H115 GC S	✓	✓
	H115 S	✓	✓
	H120 S	✓	✓*
Demolition and Sorting Grapples	G313 GC	✓	✓
	G314	✓	✓*
Mobile Scrap and Demolition Shears	S3015 Flat Top	✓	✓*
Pulverizers	P214 Secondary Pulverizer	✓*	
Compactors (Vibratory Plate)	CVP75	✓	✓
Rotary Cutters	RC15	✓	✓

### CW-30s DEDICATED COUPLER ATTACHMENTS

Boom Type	Stick Length	Reach Boom	
		R2.6 (8'6")	R2.9 (9'6")
Hydraulic Hammers	H110 S	✓	✓
	H115 GC S	✓	✓
	H115 S	✓	✓
	H120 S	✓	✓
Demolition and Sorting Grapples	G313 GC	✓	✓
	G314	✓	✓
	G317 GC	✓*	
Mobile Scrap and Demolition Shears	S3015 Flat Top	✓	✓
Pulverizers	P214 Secondary Pulverizer	✓	✓*
Compactors (Vibratory Plate)	CVP75	✓	✓
Rotary Cutters	RC15	✓	✓

*(continued on next page)*

# 317 GC Hydraulic Excavator Specifications

## Attachments Offering Guide *(continued)*

Not all Attachments are available in all regions. Consult your Cat dealer for configurations available in your region.

Match       \* Working range front only       No Match

### CW-30 DEDICATED COUPLER ATTACHMENTS

Boom Type	Stick Length	Reach Boom	
		R2.6 (8'6")	R2.9 (9'6")
Hydraulic Hammers	H110 S	✓	✓
	H115 GC S	✓	✓
	H115 S	✓	✓
	H120 S	✓	✓*
Demolition and Sorting Grapples	G313 GC	✓	✓
	G313 GC fixed CAN	✓	✓
	G314	✓	✓
	G317 GC	✓*	
	G317 GC fixed CAN	✓*	
Mobile Scrap and Demolition Shears	S3015 Flat Top	✓	✓
Pulverizers	P214 Secondary Pulverizer	✓	✓*
Compactors (Vibratory Plate)	CVP75	✓	✓
Rotary Cutters	RC15	✓	✓

### HCCW30 Dedicated Coupler Attachments

Boom Type	Stick Length	Reach Boom	
		R2.6 (8'6")	R2.9 (9'6")
Hydraulic Hammers	H110 S	✓	✓
	H115 GC S	✓	✓*
	H115 S	✓	✓
Demolition and Sorting Grapples	G313 GC	✓*	
	G314	✓*	
Mobile Scrap and Demolition Shears	S3015 Flat Top	✓*	
Compactors (Vibratory Plate)	CVP75	✓	✓
Rotary Cutters	RC15	✓	✓

### S60 DEDICATED COUPLER ATTACHMENTS

Boom Type	Stick Length	Reach Boom	
		R2.6 (8'6")	R2.9 (9'6")
Hydraulic Hammers	H110 S	✓	✓
	H115 GC S	✓	✓
	H115 S	✓	✓
	H120 S	✓	✓
Demolition and Sorting Grapples	G313 GC	✓	✓
	G314	✓	✓
	G317 GC	✓*	
Mobile Scrap and Demolition Shears	S3015 Flat Top	✓	✓
Pulverizers	P214 Secondary Pulverizer	✓	✓*
Compactors (Vibratory Plate)	CVP75	✓	✓
Rotary Cutters	RC15	✓	✓

*(continued on next page)*

# 317 GC Hydraulic Excavator Specifications

## Attachments Offering Guide *(continued)*

Not all Attachments are available in all regions. Consult your Cat dealer for configurations available in your region.

Match

\* Working range front only

No Match

### HCS60 DEDICATED COUPLER ATTACHMENTS

Boom Type	Stick Length	Reach Boom	
		R2.6 (8'6")	R2.9 (9'6")
Hydraulic Hammers	H110 S	✓	✓
	H115 S	✓	✓
	H120 S	✓	✓
Demolition and Sorting Grapples	G313 GC	✓	✓
	G314	✓	✓
Mobile Scrap and Demolition Shears	S3015 Flat Top	✓	✓
Pulverizers	P214 Secondary Pulverizer	✓	✓*
Compactors (Vibratory Plate)	CVP75	✓	✓

### HCS65 DEDICATED COUPLER ATTACHMENTS

Boom Type	Stick Length	Reach Boom	
		R2.6 (8'6")	R2.9 (9'6")
Hydraulic Hammers	H110 S	✓	✓
	H115 S	✓	✓
	H120 S	✓	✓*
Demolition and Sorting Grapples	G313 GC	✓	✓
	G314	✓	✓*
Mobile Scrap and Demolition Shears	S3015 Flat Top	✓	✓*
Pulverizers	P214 Secondary Pulverizer	✓*	
Compactors (Vibratory Plate)	CVP75	✓	✓
Rotary Cutters	RC15	✓	✓

### BOOM-MOUNT ATTACHMENTS

Boom Type	Stick Length	Reach Boom
Mobile Scrap and Demolition Shears	S3035 Flat Top	✓*

## Standard and Optional Equipment

Standard and optional equipment may vary. Consult your Cat dealer for details.

	Standard	Optional		Standard	Optional
<b>BOOMS, STICKS AND LINKAGES</b>			<b>CAT TECHNOLOGY</b>		
5.1 m (16'9") Reach boom	✓		Cat Equipment Management:		
2.6 m (8'6") Reach stick		✓	– VisionLink®	✓ <sup>1</sup>	
2.9 m (9'6") Reach stick		✓	– VisionLink Productivity		✓ <sup>2</sup>
Bucket linkage, with lifting eye	✓		– Remote Flash	✓	
<b>CAB</b>			<b>ELECTRICAL SYSTEM</b>		
ROPS	✓		Maintenance free battery	✓	
Operator Protective Guards (OPG)		✓	Centralized electrical disconnect switch	✓	
High-resolution 203 mm (8") LCD touchscreen monitor	✓		Programmable time-delay LED working lights	✓	
Automatic bi-level air conditioner	✓		LED chassis and left-side boom light – 1,800 lumens	✓	
Jog dial and shortcut keys for monitor control	✓		LED right-side boom light and cab lights – 1,800 lumens		✓
Keyless push-to-start engine control	✓		<b>ENGINE</b>		
Height-adjustable console	✓		Cat® C3.6 single turbo diesel engine	✓	
Fixed left-side console	✓		Two selectable modes: Power, Smart	✓	
Air-suspension seat	✓		One-touch low idle with automatic engine speed control	✓	
51 mm (2") seat belt	✓		Automatic engine shutdown	✓	
Bluetooth® integrated radio with USB port	✓		–18° C (–0° F) cold start capability		✓
12V DC outlets	✓		–25° C (–13° F) cold start capability		✓
Document storage	✓		Single fuel filtration system with water separator and indicator	✓	
Cup and bottle holders	✓		Sealed double element air filter with integrated pre-cleaner	✓	
Openable two-piece front window	✓		Electric fuel priming pump	✓	
Rear window emergency exit	✓		Electric cooling fans	✓	
Upper radial wiper with washer	✓				
Openable polycarbonate skylight hatch	✓				
LED dome light	✓				
Roller rear sunscreen		✓			
Washable floor mat	✓				
Beacon ready	✓				

<sup>1</sup>Provides core telematics data to manage health, maintenance insights, and condition monitoring. Other plans available for more comprehensive data reporting. Consult your Cat dealer for details.

<sup>2</sup>VisionLink subscription required. Consult your Cat dealer for details.

(continued on next page)

# 317 GC Standard and Optional Equipment

## Standard and Optional Equipment *(continued)*

Standard and optional equipment may vary. Consult your Cat dealer for details.

	Standard	Optional		Standard	Optional
<b>HYDRAULIC SYSTEM</b>			<b>SERVICE AND MAINTENANCE</b>		
Electronic main control valve	✓		Side entry to service platform	✓	
Single type electronic main pump	✓		Grouped engine oil and fuel filters	✓	
Boom and stick regeneration circuits	✓		Ground-level engine oil dipstick	✓	
Boom and stick drift reduction valve	✓		Lockable disconnect switch	✓	
Boom lowering check valve	✓		Scheduled Oil Sampling (S·O·S <sup>SM</sup> ) ports	✓	
Stick lowering check valve	✓		Integrated vehicle health management system	✓	
Automatic hydraulic oil warm up	✓		<b>UNDERCARRIAGE AND STRUCTURES</b>		
Automatic two-speed travel	✓		500 mm (20") triple grouser track shoes		✓
Element type main hydraulic filter	✓		600 mm (24") triple grouser track shoes		✓
Quick coupler circuit for Cat pin grabber		✓	700 mm (28") triple grouser track shoes with additional steps		✓
Quick coupler circuit for CW dedicated		✓	790 mm (31") triple grouser track shoes with additional steps		✓
<b>SAFETY AND SECURITY</b>			Grease lubricated track link	✓	
Rear and right-side-view cameras	✓		Center track guiding guards	✓	
Ground-level accessible secondary engine shutoff switch in cab	✓		Bottom guards	✓	
Service platform with anti-skid plate and countersunk bolts	✓		Travel motor guards	✓	
Signaling/warning horn	✓		3.05 mt (6,720 lb) counterweight		✓
Swing alarm		✓	Tie-down points at base frame	✓	
Hydraulic lock out lever	✓		2500 mm (8'2") blade		✓
Inspection lighting		✓	2600 mm (8'6") blade		✓
Auto Hammer Stop	✓		2700 mm (8'10") blade		✓

## Dealer Installed Kits and Attachments

Attachments may vary. Consult your Cat dealer for details.

### CAB

- Radial lower wiper
- Left-hand and right-hand electrical pedal (two-way) for tool control
- Dual exit rear window kit
- Rain protector plus cab light cover
- Polycarbonate roof hatch
- Key fob (for use with Bluetooth receiver)

### SAFETY AND SECURITY

- 76 mm (3") retractable seat belt
- Bluetooth receiver

### GUARDS

- OPG (not compatible with cab light cover, rain protector)
- Mesh guard full front (not compatible with cab light cover, rain protector)
- Mesh guard lower front half
- Full protecting vandalism guard

# 317 GC Environmental Declaration

The following information applies to the machine at the time of final manufacture as configured for sale in the regions covered in this document. The content of this declaration is valid as of the date issued; however, content related to machine features and specifications are subject to change without notice. For additional information, please see the machine's Operation and Maintenance Manual.

For more information on sustainability in action and our progress, please visit <https://www.caterpillar.com/en/company/sustainability>.

## Engine

- The Cat® C3.6 engine meets U.S. EPA Tier 4 Final and EU Stage V emission standards.
- Cat diesel engines are required to use ULSD (ultra-low sulfur diesel fuel with 15 ppm of sulfur or less) or ULSD blended with the following lower-carbon intensity fuels\*\* up to:
  - ✓ 20% biodiesel FAME (fatty acid methyl ester)\*
  - ✓ 100% renewable diesel, HVO (hydrotreated vegetable oil) and GTL (gas-to-liquid) fuels

Refer to guidelines for successful application. Please consult your Cat dealer or “Caterpillar Machine Fluids Recommendations” (SEBU6250) for details.

*\*Engines with no aftertreatment devices can use higher blends, up to 100% biodiesel (for use of blends higher than 20% biodiesel, consult your Cat dealer).*

*\*\*Tailpipe greenhouse gas emissions from lower-carbon intensity fuels are essentially the same as traditional fuels.*

## Air Conditioning System

- The air conditioning system on this machine contains the fluorinated greenhouse gas refrigerant R134a (Global Warming Potential = 1430). The system contains 0.9 kg (1.98 lb) of refrigerant which has a CO<sub>2</sub> equivalent of 1.287 metric tonnes (1.418 tons).

## Paint

- Based on best available knowledge, the maximum allowable concentration, measured in parts per million (PPM), of the following heavy metals in paint are:
  - Barium < 0.01%
  - Cadmium < 0.01%
  - Chromium < 0.01%
  - Lead < 0.01%

## Sound Performance

ISO 6395:2008 (external) 101 dB(A)

ISO 6396:2008 (inside cab) 70 dB(A)

- Hearing protection may be needed when operating with an open operator station and cab (when not properly maintained or doors/windows open) for extended periods or in a noisy environment.

## Oils and Fluids

- Caterpillar factory fills with ethylene glycol coolants. Cat Diesel Engine Antifreeze/Coolant (DEAC) and Cat Extended Life Coolant (ELC) can be recycled. Consult your Cat dealer for more information.
- Cat Bio HYDO™ Advanced is an EU Ecolabel approved biodegradable hydraulic oil.
- Additional fluids are likely to be present, please consult the Operations and Maintenance Manual or the Application and Installation guide for complete fluid recommendations and maintenance intervals.

## Features and Technology

- The following features and technology may contribute to fuel savings and/or carbon reduction. Features may vary. Consult your Cat dealer for details.
  - Advanced hydraulic systems balance power and efficiency
  - Smart mode matches machine power to digging requirements automatically
  - Extended service intervals help decrease maintenance costs.
  - Automatic engine speed control and engine shutdown
  - Complete work quickly and efficiently with expanded work tool offering

For more complete information on Cat products, dealer services, and industry solutions, visit us on the web at [www.cat.com](http://www.cat.com)

© 2024 Caterpillar  
All rights reserved

Materials and specifications are subject to change without notice. Featured machines in photos may include additional equipment. See your Cat dealer for available options.

CAT, CATERPILLAR, LET'S DO THE WORK, their respective logos, "Caterpillar Corporate Yellow," the "Power Edge" and Cat "Modern Hex" trade dress as well as corporate and product identity used herein, are trademarks of Caterpillar and may not be used without permission. VisionLink is a trademark of Caterpillar Inc., registered in the United States and in other countries.

AEXQ4098-00 (11-2024)  
Build Number: 07H  
(Europe)

