



317

Hydraulic Excavator

Technical Specifications

Configurations and features may vary by region. Please consult your Cat® dealer for availability in your area.

Table of Contents

Specifications	2
Engine	2
Swing Mechanism	2
Weights	2
Track	2
Drive	2
Hydraulic System	2
Service Refill Capacities	2
Standards	3
Sound Performance	3
Operating Weights and Ground Pressures	3
Air Conditioning System	3
Major Component Weights	4
Dimensions	5
Working Ranges and Forces	7
Blade Working Ranges	9
Reach Boom Lift Capacities:	
Without Blade	10
With Blade Up	18
Variable Angle Boom Lift Capacities:	
Without Blade	14
With Blade Up	22
Bucket Specifications and Compatibility:	
Europe	26
Australia and New Zealand	29
Attachments Offering Guide:	
Europe	30
Australia and New Zealand	37
Standard and Optional Equipment	38
Dealer Installed Kits and Attachments	40
Cab Options	41
317 Environmental Declaration	42

317 Hydraulic Excavator Specifications

Engine

Engine Model	Cat® C3.6	
Net Power		
ISO 9249	98.9 kW	133 hp
ISO 9249 (DIN)	134 hp (metric)	
Engine Power		
ISO 14396	100 kW	134 hp
ISO 14396 (DIN)	136 hp (metric)	
Bore	98 mm	4 in
Stroke	120 mm	5 in
Displacement	3.6 L	220 in ³
Biodiesel Capability	up to B20 ⁽¹⁾	

- Meets U.S. EPA Tier 4 Final, EU Stage V, and Japan 2014 emission standards.
- No engine power derate required below 3000 m (9,840 ft) altitude.
- Advertised power is tested per the specified standard in effect at the time of manufacture.
- Net power advertised is the power available at the flywheel when the engine is equipped with fan, air intake system, exhaust system and alternator.
- Engine speed at 2,200 rpm.

⁽¹⁾Cat diesel engines are required to use ULSD (ultra-low sulfur diesel fuel with 15 ppm of sulfur or less) or ULSD blended with the following lower-carbon intensity fuels** up to:

- ✓ 20% biodiesel FAME (fatty acid methyl ester)*
- ✓ 100% renewable diesel, HVO (hydrotreated vegetable oil) and GTL (gas-to-liquid) fuels

Refer to guidelines for successful application. Please consult your Cat dealer or “Caterpillar Machine Fluids Recommendations” (SEBU6250) for details.

**Engines with no aftertreatment devices can use higher blends, up to 100% biodiesel (for use of blends higher than 20% biodiesel, consult your Cat dealer).*

***Tailpipe greenhouse gas emissions from lower-carbon intensity fuels are essentially the same as traditional fuels.*

Swing Mechanism

Swing Speed*	8.7 rpm	
Maximum Swing Torque	64.6 kN·m	47,647 lbf·ft

*CE-marked machine default value may be set lower.

Weights

Operating Weight	17 800 kg	39,300 lb
• Long undercarriage, Reach boom, R3.1 (10'2") stick, General Duty (GD) 1.00 m ³ (1.31 yd ³) bucket, 500 mm (20") triple grouser shoes and 3.77 mt (8,311 lb) counterweight.		
Operating Weight	18 400 kg	40,500 lb
• Long undercarriage, Variable Angle (VA) boom, R2.6 (8'6") stick, GD 1.00 m ³ (1.31 yd ³) bucket, 500 mm (20") triple grouser shoes and 3.77 mt (8,311 lb) counterweight.		

Track

Optional Track Shoes Width	500 mm	20 in
Optional Track Shoes Width	600 mm	24 in
Optional Track Shoes Width	700 mm	28 in
Optional Track Shoes Width	790 mm	31 in
Number of Shoes (each side)	44	
Number of Track Rollers (each side)	7	
Number of Carrier Rollers (each side)	2	

Drive

Gradeability	35°/70%	
Maximum Travel Speed	5.3 km/h	3.3 mph
Maximum Drawbar Pull	157 kN	35,295 lbf

Hydraulic System

Main System – Maximum Flow – Implement	296 L/min	78 gal/min
Maximum Flow – Medium Pressure (MP) Circuit	60 L/min	16 gal/min
Maximum Flow – High Pressure (HP) Auxiliary (AUX) Circuit	291 L/min	77 gal/min
Maximum Pressure – Equipment	35 000 kPa	5,076 psi
Maximum Pressure – Travel	35 000 kPa	5,076 psi
Maximum Pressure – Swing	25 800 kPa	3,741 psi
Boom Cylinder – Bore	110 mm	4.3 in
Boom Cylinder – Stroke	1193 mm	47.0 in
VA Boom Cylinder – Bore	140 mm	5.5 in
VA Boom Cylinder – Stroke	865 mm	34.1 in
Stick Cylinder – Bore	120 mm	4.7 in
Stick Cylinder – Stroke	1331 mm	52.4 in
Bucket Cylinder – Bore	105 mm	4.1 in
Bucket Cylinder – Stroke	1039 mm	40.9 in

Service Refill Capacities

Fuel Tank Capacity	271 L	71.6 gal
Cooling System	22 L	5.8 gal
Engine Oil	11 L	2.9 gal
Final Drive (each)	6 L	1.6 gal
Hydraulic System (including tank)	94 L	24.8 gal
Hydraulic Tank	87 L	23.0 gal
Diesel Exhaust Fluid (DEF) Tank	22 L	5.9 gal

317 Hydraulic Excavator Specifications

Standards

Brakes	ISO 10265:2008
Cab/Rollover Protective Structure (ROPS)	ISO 12117-2:2008
Cab/Operator Protective Guards (OPG) (optional)	ISO 10262:1998 (Level II)

Sound Performance

ISO 6395:2008 external	101 dB(A)
ISO 6396:2008 internal	72 dB(A)

- Hearing protection may be needed when operating with an open operator station and cab (when not properly maintained or doors/windows open) for extended periods or in a noisy environment.

Air Conditioning System

The air conditioning system on this machine contains the fluorinated greenhouse gas refrigerant R134a (Global Warming Potential = 1430). The system contains 0.9 kg of refrigerant which has a CO₂ equivalent 1.287 metric tonne.

Operating Weights and Ground Pressures

	500 mm (20") Triple Grouser Shoes		600 mm (24") Triple Grouser Shoes		700 mm (28") Triple Grouser Shoes		790 mm (31") Triple Grouser Shoes	
	Weight	Ground Pressure	Weight	Ground Pressure	Weight	Ground Pressure	Weight	Ground Pressure
	kg (lb)	kPa (psi)	kg (lb)	kPa (psi)	kg (lb)	kPa (psi)	kg (lb)	kPa (psi)
Base machine with 3.77 mt (8,311 lb) Counterweight and Long Undercarriage								
Reach Boom + R2.6 (8'6") Stick + 0.91 m ³ (1.19 yd ³) GD Bucket	17 700 (39,100)	50.4 (7.3)	18 000 (39,600)	42.5 (6.2)	18 200 (40,100)	36.9 (5.4)	18 600 (41,000)	33.4 (4.8)
Reach Boom + R3.1 (10'2") Stick + 0.91 m ³ (1.19 yd ³) GD Bucket	17 800 (39,300)	50.6 (7.3)	18 000 (39,800)	42.7 (6.2)	18 300 (40,300)	37.1 (5.4)	18 700 (41,100)	33.5 (4.9)
Reach Boom + R2.6 (8'6") Stick + 1.00 m ³ (1.31 yd ³) GD Bucket	17 800 (39,200)	50.5 (7.3)	18 000 (39,700)	42.6 (6.2)	18 200 (40,200)	37.0 (5.4)	18 600 (41,000)	33.5 (4.9)
Reach Boom + R2.6 (8'6") Stick + 1.00 m ³ (1.31 yd ³) GD Bucket + blade	18 600 (41,100)	53.0 (7.7)	18 900 (41,600)	44.7 (6.5)	19 100 (42,200)	38.8 (5.6)	19 500 (43,000)	35.1 (5.1)
Reach Boom + R3.1 (10'2") Stick + 1.00 m ³ (1.31 yd ³) GD Bucket	17 800 (39,300)	50.7 (7.4)	18 100 (39,800)	42.8 (6.2)	18 300 (40,400)	37.1 (5.4)	18 700 (41,200)	33.6 (4.9)
Reach Boom + R3.1 (10'2") Stick + 1.00 m ³ (1.31 yd ³) GD Bucket + blade	18 700 (41,300)	53.2 (7.7)	18 900 (41,600)	44.7 (6.5)	19 200 (42,400)	39.0 (5.7)	19 600 (43,200)	35.3 (5.1)
Variable Angle Boom + R2.25 (7'5") Stick + 0.91 m ³ (1.19 yd ³) GD Bucket	18 300 (40,400)	52.0 (7.5)	18 500 (40,800)	43.9 (6.4)	18 800 (41,400)	38.1 (5.5)	19 200 (42,200)	34.4 (5.0)
Variable Angle Boom + R2.6 (8'6") Stick + 0.91 m ³ (1.19 yd ³) GD Bucket	18 300 (40,400)	52.1 (7.6)	18 600 (40,900)	44.0 (6.4)	18 800 (41,500)	38.2 (5.5)	19 200 (42,300)	34.5 (5.0)
Variable Angle Boom + R2.25 (7'5") Stick + 1.00 m ³ (1.31 yd ³) GD Bucket	18 300 (40,400)	52.1 (7.6)	18 600 (40,900)	43.9 (6.4)	18 800 (41,400)	38.1 (5.5)	19 200 (42,300)	34.5 (5.0)
Variable Angle Boom + R2.25 (7'5") Stick + 1.00 m ³ (1.31 yd ³) GD Bucket + blade	19 200 (42,400)	54.6 (7.9)	19 500 (42,900)	46.1 (6.7)	19 700 (43,400)	40.0 (5.8)	20 100 (44,300)	36.2 (5.3)
Variable Angle Boom + R2.6 (8'6") Stick + 1.00 m ³ (1.31 yd ³) GD Bucket	18 400 (40,500)	52.2 (7.6)	18 600 (41,000)	44.1 (6.4)	18 800 (41,500)	38.2 (5.5)	19 200 (42,400)	34.6 (5.0)
Variable Angle Boom + R2.6 (8'6") Stick + 1.00 m ³ (1.31 yd ³) GD Bucket + blade	19 300 (42,500)	54.8 (7.9)	19 500 (43,000)	46.2 (6.7)	19 800 (43,500)	40.1 (5.8)	20 100 (44,400)	36.2 (5.3)

All operating weights include a 90% fuel tank with 75 kg (165 lb) operator.

317 Hydraulic Excavator Specifications

Major Component Weights

	kg	lb
Base Machine (with 3.77 mt [8,311 lb] counterweight, upper frame, long undercarriage – does not include boom, stick, bucket, boom cylinders, stick cylinder, bucket cylinders, tracks, 90% fuel tank and 75 kg [165 lb] operator).		
For use with Reach Boom	12 200	26,900
For use with Variable Angle Boom	12 200	26,900
Track Shoes:		
500 mm (20") Triple Grouser Track Shoes	2110	4,660
600 mm (24") Triple Grouser Track Shoes	2340	5,160
700 mm (28") Triple Grouser Track Shoes with Additional Steps	2580	5,680
790 mm (31") Triple Grouser Track Shoes with Additional Steps	2970	6,540
Two Boom Cylinders	300	670
Weight of 90% Fuel Tank and 75 kg (165 lb) Operator	300	660
Counterweight:		
3.77 mt (8,311 lb) Counterweight	3770	8,311
Swing Frame	1700	3,760
Undercarriage:		
Base Frame with Long Undercarriage	3900	8,600
Booms (including lines, pins, stick cylinder):		
Reach Boom 5.1 m (16'9")	1320	2,910
Variable Angle Boom (2.64 m [8'8"] Stub + 2.6 m [8'6"] Fore)	1940	4,270
Sticks (including lines, pins, bucket cylinder, bucket linkage):		
Reach Stick R2.6 (8'6")	810	1,780
Reach Stick R3.1 (10'2")	880	1,940
Reach Stick R2.25 (7'5") including HP, MP, Quick Coupler (QC) AUX line	760	1,680
Buckets (without linkage):		
0.62 m ³ (0.81 yd ³) GD Bucket	730	1,610
0.91 m ³ (1.19 yd ³) GD Bucket	690	1,510
1.00 m ³ (1.31 yd ³) GD Bucket	740	1,620
Quick Coupler:		
Pin Grabber Quick Coupler	260	580

317 Hydraulic Excavator Specifications

Dimensions

All dimensions are approximate and may vary depending on bucket selection.

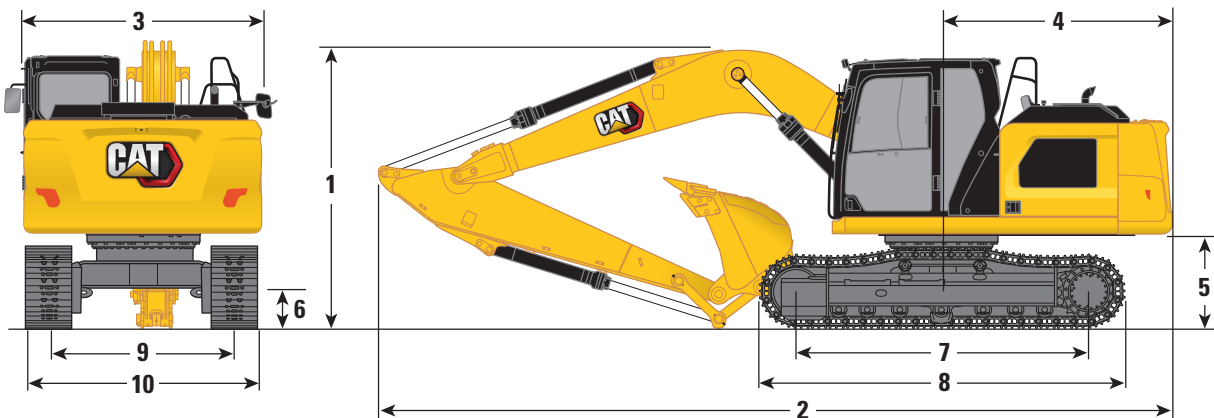

Boom Option	Reach Boom 5.1 m (16'9")			
	Reach Stick R2.6 (8'6")		Reach Stick R3.1 (10'2")	
1 Machine Height:				
Top of Cab Height	2930 mm	9'7"	2930 mm	9'7"
Top of OPG Height	3070 mm	10'1"	3070 mm	10'1"
Handrail Height	2940 mm	9'8"	2940 mm	9'8"
With Boom/Stick/Bucket Installed (with stick cylinder lines)	3030 mm	9'9"	3140 mm	10'3"
With Boom/Stick Installed (with stick cylinder lines)	2940 mm	9'6"	3030 mm	9'9"
With Boom Installed (with stick cylinder lines)	2520 mm	8'3"	2520 mm	8'3"
2 Machine Length (without Blade):				
With Boom/Stick/Bucket Installed (with stick cylinder lines)	8560 mm	28'1"	8580 mm	28'2"
With Boom/Stick Installed (with stick cylinder lines)	8530 mm	28'0"	8570 mm	28'1"
With Boom Installed (with stick cylinder lines)	7630 mm	25'0"	7630 mm	25'0"
Machine Length (with Blade, Blade Rear):				
With Boom/Stick/Bucket Installed (with stick cylinder lines)	8600 mm	28'2"	8620 mm	28'3"
With Boom/Stick Installed (with stick cylinder lines)	8570 mm	28'1"	8610 mm	28'3"
With Boom Installed (with stick cylinder lines)	7670 mm	25'2"	7670 mm	25'2"
3 Upperframe Width	2540 mm	8'4"	2540 mm	8'4"
4 Tail Swing Radius:				
3.77 mt (8,311 lb) Counterweight	2500 mm	8'2"	2500 mm	8'2"
5 Counterweight Clearance	1010 mm	3'4"	1010 mm	3'4"
6 Ground Clearance	430 mm	1'5"	430 mm	1'5"
7 Length to Center of Rollers	3170 mm	10'5"	3170 mm	10'5"
8 Track Length	3970 mm	13'0"	3970 mm	13'0"
9 Track Gauge	1990 mm	6'6"	1990 mm	6'6"
10 Undercarriage Width:				
500 mm (20") Shoes	2490 mm	8'2"	2490 mm	8'2"
600 mm (24") Shoes	2590 mm	8'6"	2590 mm	8'6"
700 mm (28") Shoes (with steps)	2690 mm	8'10"	2690 mm	8'10"
790 mm (31") Offset Shoes (with steps)	2870 mm	9'5"	2870 mm	9'5"
Bucket Type	GD		GD	
Bucket Capacity	1.00 m ³	1.31 yd ³	1.00 m ³	1.31 yd ³
Bucket Tip Radius	1390 mm	4'7"	1390 mm	4'7"

317 Hydraulic Excavator Specifications

Dimensions

All dimensions are approximate and may vary depending on bucket selection.

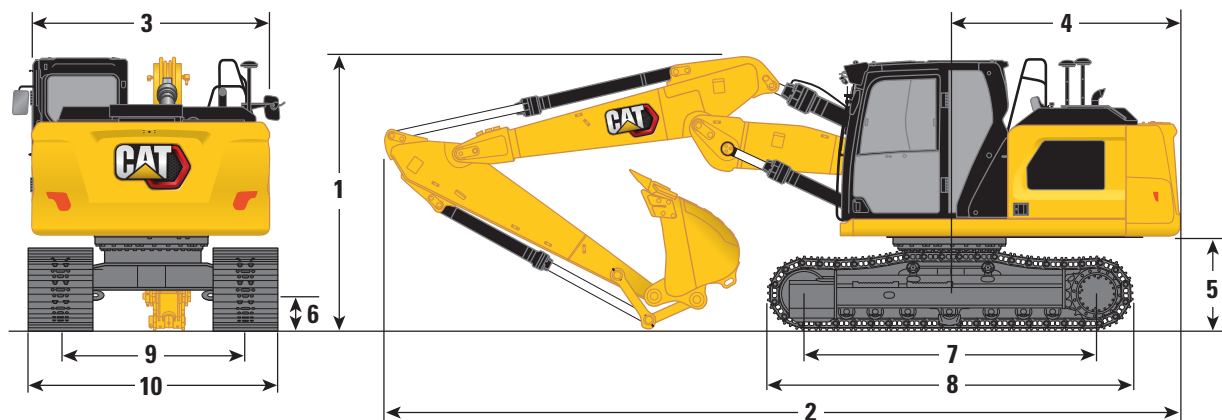

Boom Option

Variable Angle Boom
2.64 m/2.6 m (8'8"/8'6")

Stick Options

Reach Stick
R2.25 (7'5")

Reach Stick
R2.6 (8'6")

1 Machine Height:

	2.25 m (7'5")	2.6 m (8'6")	2.64 m (8'8")	2.6 m (8'6")
Top of Cab Height	2930 mm	9'7"	2930 mm	9'7"
Top of OPG Height	3070 mm	10'1"	3070 mm	10'1"
Handrail Height	2940 mm	9'8"	2940 mm	9'8"
With Boom/Stick/Bucket Installed (with stick cylinder lines)	2840 mm	9'4"	2990 mm	9'10"
With Boom/Stick Installed (with stick cylinder lines)	2710 mm	8'11"	2800 mm	9'2"
With Boom Installed (with stick cylinder lines)	2180 mm	7'2"	2180 mm	7'2"

2 Machine Length (without Blade):

With Boom/Stick/Bucket Installed (with stick cylinder lines)	8630 mm	28'3"	8620 mm	28'3"
With Boom/Stick Installed (with stick cylinder lines)	8620 mm	28'3"	8630 mm	28'3"
With Boom Installed (with stick cylinder lines)	7680 mm	25'2"	7680 mm	25'2"

Machine Length (with Blade, Blade Rear):

With Boom/Stick/Bucket Installed (with stick cylinder lines)	8670 mm	28'5"	8660 mm	28'4"
With Boom/Stick Installed (with stick cylinder lines)	8660 mm	28'5"	8670 mm	28'5"
With Boom Installed (with stick cylinder lines)	7730 mm	25'4"	7730 mm	25'4"

3 Upperframe Width

	2540 mm	8'4"	2540 mm	8'4"
--	---------	------	---------	------

4 Tail Swing Radius:

3.77 mt (8,311 lb) Counterweight	2500 mm	8'2"	2500 mm	8'2"
----------------------------------	---------	------	---------	------

5 Counterweight Clearance

	1010 mm	3'4"	1010 mm	3'4"
--	---------	------	---------	------

6 Ground Clearance

	430 mm	1'5"	430 mm	1'5"
--	--------	------	--------	------

7 Length to Center of Rollers

	3170 mm	10'5"	3170 mm	10'5"
--	---------	-------	---------	-------

8 Track Length

	3970 mm	13'0"	3970 mm	13'0"
--	---------	-------	---------	-------

9 Track Gauge

	1990 mm	6'6"	1990 mm	6'6"
--	---------	------	---------	------

10 Undercarriage Width:

500 mm (20") Shoes	2490 mm	8'2"	2490 mm	8'2"
600 mm (24") Shoes	2590 mm	8'6"	2590 mm	8'6"
700 mm (28") Shoes (with steps)	2690 mm	8'10"	2690 mm	8'10"
790 mm (31") Offset Shoes (with steps)	2870 mm	9'5"	2870 mm	9'5"

Bucket Type

GD

GD

Bucket Capacity	1.00 m ³	1.31 yd ³	1.00 m ³	1.31 yd ³
-----------------	---------------------	----------------------	---------------------	----------------------

Bucket Tip Radius	1390 mm	4'7"	1390 mm	4'7"
-------------------	---------	------	---------	------

317 Hydraulic Excavator Specifications

Working Ranges and Forces

All dimensions are approximate and may vary depending on bucket selection.

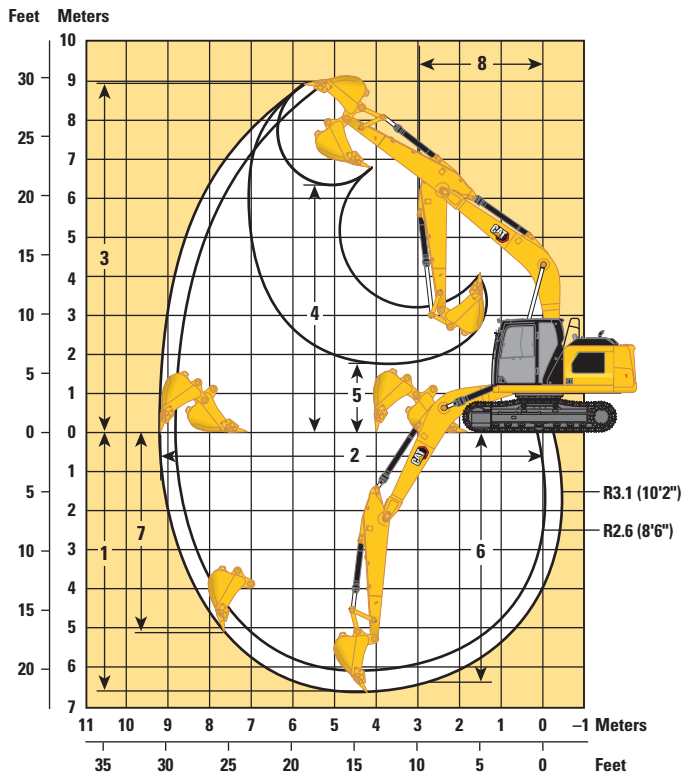

Boom Option

Reach Boom 5.1 m (16'9")

Stick Options

Reach Stick R2.6 (8'6")

Reach Stick R3.1 (10'2")

	Reach Stick R2.6 (8'6")		Reach Stick R3.1 (10'2")	
1 Maximum Digging Depth	6100 mm	20'0"	6600 mm	21'8"
2 Maximum Reach at Ground Line	8790 mm	28'10"	9200 mm	30'2"
3 Maximum Cutting Height	8940 mm	29'4"	8990 mm	29'6"
4 Maximum Loading Height	6270 mm	20'7"	6370 mm	20'11"
5 Minimum Loading Height	2290 mm	7'6"	1790 mm	5'10"
6 Maximum Depth Cut for 2440 mm (8'0") Level Bottom	5880 mm	19'3"	6380 mm	20'11"
7 Maximum Vertical Wall Digging Depth	4980 mm	16'4"	5150 mm	16'11"
8 Minimum Working Equipment Radius	2980 mm	9'9"	2930 mm	9'7"
Bucket Digging Force (ISO)	123 kN	27,650 lbf	123 kN	27,650 lbf
Stick Digging Force (ISO)	80 kN	17,980 lbf	71 kN	15,960 lbf
Bucket Type	GD		GD	
Bucket Capacity	1.00 m ³	1.31 yd ³	1.00 m ³	1.31 yd ³
Bucket Tip Radius	1390 mm	4'7"	1390 mm	4'7"

317 Hydraulic Excavator Specifications

Working Ranges and Forces

All dimensions are approximate and may vary depending on bucket selection.

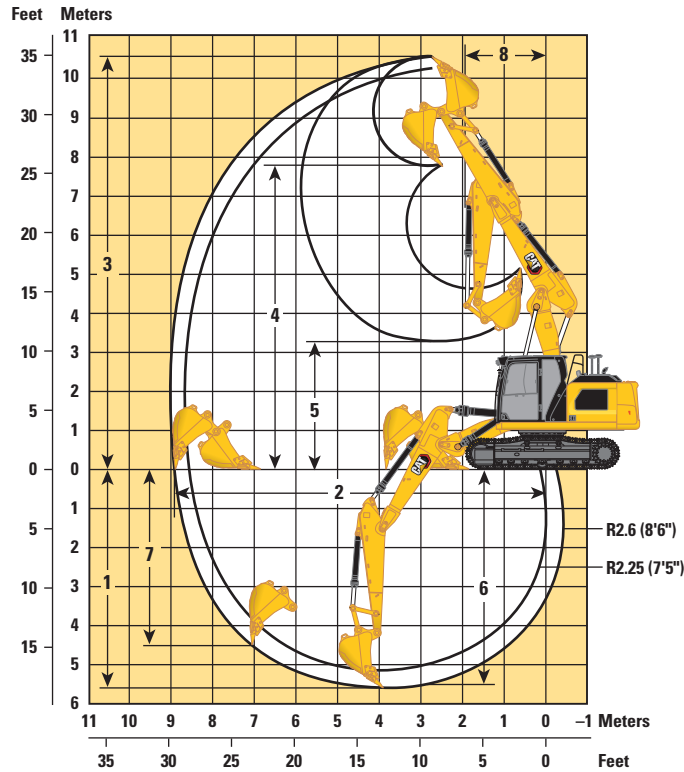

Boom Option

Variable Angle Boom
2.64 m/2.6 m (8'8"/8'6")

Stick Options

Reach Stick
R2.25 (7'5")

Reach Stick
R2.6 (8'6")

	Reach Stick R2.25 (7'5")		Reach Stick R2.6 (8'6")	
1 Maximum Digging Depth	5180 mm	17'0"	5520 mm	18'1"
2 Maximum Reach at Ground Line	8650 mm	28'5"	8980 mm	29'6"
3 Maximum Cutting Height	10 270 mm	33'8"	10 570 mm	34'8"
4 Maximum Loading Height	7530 mm	24'8"	7850 mm	25'9"
5 Minimum Loading Height	3580 mm	11'9"	3280 mm	10'9"
6 Maximum Depth Cut for 2440 mm (8'0") Level Bottom	5040 mm	16'6"	5400 mm	17'9"
7 Maximum Vertical Wall Digging Depth	3120 mm	10'3"	4510 mm	14'10"
8 Minimum Working Equipment Radius	1810 mm	5'11"	1980 mm	6'6"
Bucket Digging Force (ISO)	123 kN	27,650 lbf	123 kN	27,650 lbf
Stick Digging Force (ISO)	88 kN	19,780 lbf	80 kN	17,980 lbf
Bucket Type	GD		GD	
Bucket Capacity	1.00 m ³	1.31 yd ³	1.00 m ³	1.31 yd ³
Bucket Tip Radius	1390 mm	4'7"	1390 mm	4'7"

317 Hydraulic Excavator Specifications

Blade Working Ranges

All dimensions are approximate and may vary depending on bucket selection.

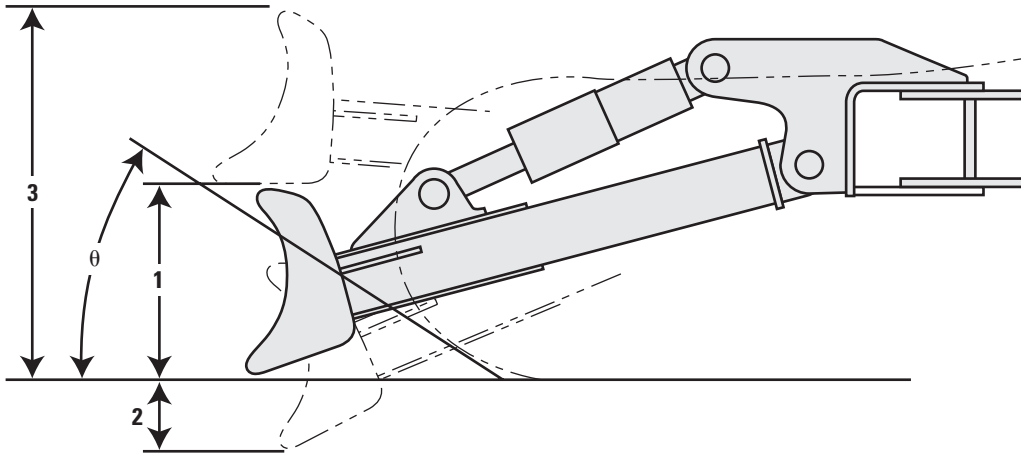

Blade Working Ranges

Blade Options	Blade					
	2500 mm (8'2")		2600 mm (8'6")		2700 mm (8'10")	
1 Blade Height	614 mm	2'0"	614 mm	2'0"	614 mm	2'0"
2 Maximum Lowering Depth from Ground	518 mm	1'8"	518 mm	1'8"	518 mm	1'8"
3 Maximum Raising Height above Ground	976 mm	3'2"	976 mm	3'2"	976 mm	3'2"
θ Approach Angle	23.5°		23.5°		23.5°	

317 Hydraulic Excavator Specifications

Reach Boom Lift Capacities – Counterweight: 3.77 mt (8,311 lb) – without Bucket

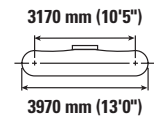
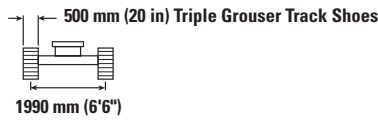
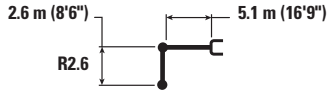

Reach Boom Lift Configuration	1500 mm/5'0"		3000 mm/10'0"		4500 mm/15'0"		6000 mm/20'0"		7500 mm/25'0"		mm ft/in		
	kg lb	kg lb	kg lb	kg lb	kg lb	kg lb	kg lb	kg lb	kg lb	kg lb	kg lb	mm ft/in	
7500 mm 25'0"					*7,700	*7,700					*3350 *7,450	*3350 *7,450	4770 15'1"
6000 mm 20'0"							*3600 *6,650	*3600 *6,650			*2950 *6,450	*2950 *6,450	6190 20'0"
4500 mm 15'0"					*4650 *10,050	*4650 *10,050	*4300 *9,450	3650 7,800			*2850 *6,200	*2850 *6,200	7020 22'10"
3000 mm 10'0"			*8900 *18,900	*8900 *18,900	*5900 *12,700	5300 11,450	*4850 *10,500	3500 7,550			*2900 *6,300	2550 5,600	7450 24'4"
1500 mm 5'0"					*7250 *15,600	5000 10,750	5300 11,450	3350 7,250	*3500 2450		*3050 *6,750	2450 5,300	7560 24'9"
0 mm 0'0"			*6200 *14,200	*6200 *14,200	8000 17,150	4800 10,250	5200 11,150	3250 7,000			*3450 *7,600	2450 5,400	7370 24'2"
-1500 mm -5'0"	kg lb	*5650 *12,650	*5650 *12,650	*10 050 *22,950	8600 18,450	7900 17,000	4700 10,100	5150 11,050	3200 6,900		*4200 *9,300	2700 5,950	6850 22'4"
-3000 mm -10'0"	kg lb	*9900 *22,300	*9900 *22,300	*10 750 *23,250	8750 18,750	*7450 *16,050	4750 10,250				5350 *11,800	3350 7,400	5900 19'2"
-4500 mm -15'0"	kg lb			*7750 *16,400	*7750 *16,400						*5450 *11,900	5400 *11,900	4240 13'6"

Reach Boom Lift Capacities – Counterweight: 3.77 mt (8,311 lb) – without Bucket

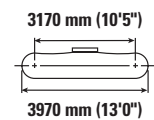
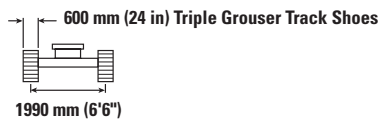

Reach Boom Lift Configuration	1500 mm/5'0"		3000 mm/10'0"		4500 mm/15'0"		6000 mm/20'0"		7500 mm/25'0"		mm ft/in		
	kg lb	kg lb	kg lb	kg lb	kg lb	kg lb	kg lb	kg lb	kg lb	kg lb	kg lb	mm ft/in	
7500 mm 25'0"					*7,700	*7,700					*3350 *7,450	*3350 *7,450	4770 15'1"
6000 mm 20'0"							*3600 *6,650	*3600 *6,650			*2950 *6,450	*2950 *6,450	6190 20'0"
4500 mm 15'0"					*4650 *10,050	*4650 *10,050	*4300 *9,450	3700 7,900			*2850 *6,200	*2850 *6,200	7020 22'10"
3000 mm 10'0"			*8900 *18,900	*8900 *18,900	*5900 *12,700	5350 11,550	*4850 *10,500	3550 7,650			*2900 *6,300	2550 5,650	7450 24'4"
1500 mm 5'0"					*7250 *15,600	5050 10,850	5400 11,550	3400 7,300	*3500 2500		*3050 *6,750	2450 5,400	7560 24'9"
0 mm 0'0"			*6200 *14,200	*6200 *14,200	*8050 17,350	4850 10,400	5250 11,300	3300 7,050			*3450 *7,600	2500 5,500	7370 24'2"
-1500 mm -5'0"	kg lb	*5650 *12,650	*5650 *12,650	*10 050 *22,950	8700 18,650	8000 17,200	4750 10,250	5200 11,200	3250 6,950		*4200 *9,300	2750 6,050	6850 22'4"
-3000 mm -10'0"	kg lb	*9900 *22,300	*9900 *22,300	*10 750 *23,250	8800 18,950	*7450 *16,050	4800 10,350				*5350 *11,800	3400 7,500	5900 19'2"
-4500 mm -15'0"	kg lb			*7750 *16,400	*7750 *16,400						*5450 *11,900	5400 *11,900	4240 13'6"



ISO 10567:2007



* Indicates that the load is limited by hydraulic lifting capacity rather than tipping load. The above loads are in compliance with hydraulic excavator lift capacity standard ISO 10567:2007. They do not exceed 87% of hydraulic lifting capacity or 75% of tipping load. Weight of all lifting accessories must be deducted from the above lifting capacities. Lifting capacities are based on the machine standing on a firm, uniform supporting surface. The use of a work tool attachment point to handle/lift objects, could affect the machine lift performance.

Lift capacity stays with ±5% for all available track shoes.

Always refer to the appropriate Operation and Maintenance Manual for specific product information.

317 Hydraulic Excavator Specifications

Reach Boom Lift Capacities – Counterweight: 3.77 mt (8,311 lb) – without Bucket

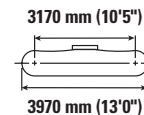
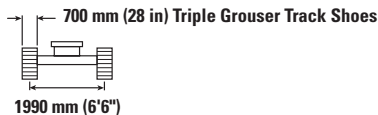
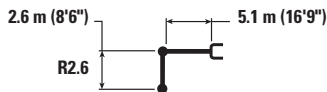

		1500 mm/5'0"		3000 mm/10'0"		4500 mm/15'0"		6000 mm/20'0"		7500 mm/25'0"		mm ft/in		
7500 mm 25'0"	kg lb					*7,700	*7,700					*3350 *7,450	*3350 *7,450	4770 15'1"
6000 mm 20'0"	kg lb							*3600 *6,650	*3600 *6,650			*2950 *6,450	*2950 *6,450	6190 20'0"
4500 mm 15'0"	kg lb					*4650 *10,050	*4650 *10,050	*4300 *9,450	3700 8,000			*2850 *6,200	*2850 *6,200	7020 22'10"
3000 mm 10'0"	kg lb			*8900 *18,900	*8900 *18,900	*5900 *12,700	5400 11,650	*4850 *10,500	3600 7,700			*2900 *6,300	2600 5,700	7450 24'4"
1500 mm 5'0"	kg lb					*7250 *15,600	5100 10,950	5450 11,700	3450 7,400	*3500	2500	*3050 *6,750	2500 5,450	7560 24'9"
0 mm 0'0"	kg lb			*6200 *14,200	*6200 *14,200	*8050 *17,400	4900 10,500	5300 11,450	3350 7,150			*3450 *7,600	2550 5,550	7370 24'2"
-1500 mm -5'0"	kg lb	*5650 *12,650	*5650 *12,650	*10 050 *22,950	8800 18,850	8100 17,400	4800 10,350	5250 11,350	3300 7,050			*4200 *9,300	2800 6,100	6850 22'4"
-3000 mm -10'0"	kg lb	*9900 *22,300	*9900 *22,300	*10 750 *23,250	8900 19,150	*7450 *16,050	4850 10,450					*5350 *11,800	3400 7,550	5900 19'2"
-4500 mm -15'0"	kg lb			*7750 *16,400	*7750 *16,400							*5450 *11,900	*5450 *11,900	4240 13'6"

Reach Boom Lift Capacities – Counterweight: 3.77 mt (8,311 lb) – without Bucket

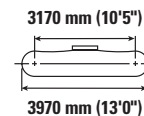
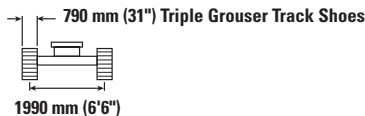
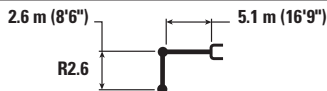

		1500 mm/5'0"		3000 mm/10'0"		4500 mm/15'0"		6000 mm/20'0"		7500 mm/25'0"		mm ft/in		
7500 mm 25'0"	kg lb					*7,700	*7,700					*3350 *7,450	*3350 *7,450	4770 15'1"
6000 mm 20'0"	kg lb							*3600 *6,650	*3600 *6,650			*2950 *6,450	*2950 *6,450	6190 20'0"
4500 mm 15'0"	kg lb					*4650 *10,050	*4650 *10,050	*4300 *9,450	3800 8,100			*2850 *6,200	*2850 *6,200	7020 22'10"
3000 mm 10'0"	kg lb			*8900 *18,900	*8900 *18,900	*5900 *12,700	5500 11,850	*4850 *10,500	3650 7,850			*2900 *6,300	2650 5,800	7450 24'4"
1500 mm 5'0"	kg lb					*7250 *15,600	5200 11,150	*5450 *11,850	3500 7,550	*3500	2550	*3050 *6,750	2550 5,550	7560 24'9"
0 mm 0'0"	kg lb			*6200 *14,200	*6200 *14,200	*8050 *17,400	5000 10,700	5450 11,650	3400 7,300			*3450 *7,600	2600 5,650	7370 24'2"
-1500 mm -5'0"	kg lb	*5650 *12,650	*5650 *12,650	*10 050 *22,950	8950 19,200	*8150 *17,650	4900 10,550	5400 11,550	3350 7,200			*4200 *9,300	2850 6,250	6850 22'4"
-3000 mm -10'0"	kg lb	*9900 *22,300	*9900 *22,300	*10 750 *23,250	9100 19,500	*7450 *16,050	4950 10,650					*5350 *11,800	3500 7,700	5900 19'2"
-4500 mm -15'0"	kg lb			*7750 *16,400	*7750 *16,400							*5450 *11,900	*5450 *11,900	4240 13'6"



ISO 10567:2007



* Indicates that the load is limited by hydraulic lifting capacity rather than tipping load. The above loads are in compliance with hydraulic excavator lift capacity standard ISO 10567:2007. They do not exceed 87% of hydraulic lifting capacity or 75% of tipping load. Weight of all lifting accessories must be deducted from the above lifting capacities. Lifting capacities are based on the machine standing on a firm, uniform supporting surface. The use of a work tool attachment point to handle/lift objects, could affect the machine lift performance.

Lift capacity stays with ±5% for all available track shoes.

Always refer to the appropriate Operation and Maintenance Manual for specific product information.

317 Hydraulic Excavator Specifications

Reach Boom Lift Capacities – Counterweight: 3.77 mt (8,311 lb) – without Bucket

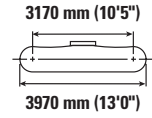
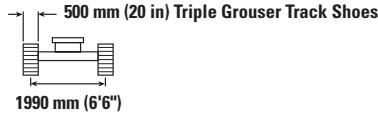
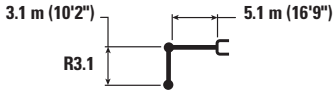

		1500 mm/5'0"		3000 mm/10'0"		4500 mm/15'0"		6000 mm/20'0"		7500 mm/25'0"		mm ft/in		
7500 mm 25'0"	kg lb											*2700 *6,050	*2700 *6,050	5380 17'2"
6000 mm 20'0"	kg lb							*3650 *7,550	*3650 *7,550			*2450 *5,400	*2450 *5,400	6670 21'7"
4500 mm 15'0"	kg lb							*3900 *8,500	3700 7,900			*2400 *5,250	*2400 *5,250	7440 24'3"
3000 mm 10'0"	kg lb			*7500 *15,950	*7500 *15,950	*5300 *11,450	*5300 *11,450	*4500 *9,700	3550 7,600	*3600 *7,100	2500 5,400	*2450 *5,400	2350 5,150	7850 25'8"
1500 mm 5'0"	kg lb			*8250 *19,750	*8250 *19,350	*6750 *14,550	5050 10,800	*5150 *11,200	3350 7,250	3850 8,200	2450 5,250	*2650 *5,800	2250 4,900	7960 26'1"
0 mm 0'0"	kg lb			*7150 *16,450	*7150 *16,450	*7750 *16,800	4750 10,250	5200 11,150	3250 6,950	3750 8,100	2400 5,100	*3000 *6,550	2250 4,950	7780 25'5"
-1500 mm -5'0"	kg lb	*5400 *12,050	*5400 *12,050	*9700 *22,100	8500 18,200	7850 16,850	4650 10,000	5100 10,950	3150 6,800			*3600 *7,950	2450 5,400	7280 23'10"
-3000 mm -10'0"	kg lb	*8700 *19,450	*8700 *19,450	*11,400 *24,650	8600 18,400	*7750 *16,700	4650 10,050	5100 11,000	3150 6,850			4700 10,400	2950 6,500	6400 20'10"
-4500 mm -15'0"	kg lb			*9100 *19,350	8850 18,950	*6150 *12,950	4800 10,400					*5450 *12,000	4300 9,700	4920 15'9"

Reach Boom Lift Capacities – Counterweight: 3.77 mt (8,311 lb) – without Bucket

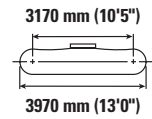
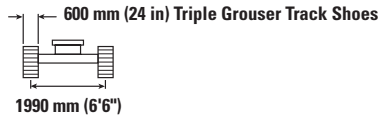

		1500 mm/5'0"		3000 mm/10'0"		4500 mm/15'0"		6000 mm/20'0"		7500 mm/25'0"		mm ft/in		
7500 mm 25'0"	kg lb											*2700 *6,050	*2700 *6,050	5380 17'2"
6000 mm 20'0"	kg lb							*3650 *7,550	*3650 *7,550			*2450 *5,400	*2450 *5,400	6670 21'7"
4500 mm 15'0"	kg lb							*3900 *8,500	3700 7,950			*2400 *5,250	*2400 *5,250	7440 24'3"
3000 mm 10'0"	kg lb			*7500 *15,950	*7500 *15,950	*5300 *11,450	*5300 *11,450	*4500 *9,700	3550 7,650	*3600 *7,100	2550 5,450	*2450 *5,400	2350 5,200	7850 25'8"
1500 mm 5'0"	kg lb			*8250 *19,750	*8250 *19,550	*6750 *14,550	5100 10,950	*5150 *11,200	3400 7,300	3850 8,300	2450 5,300	*2650 *5,800	2250 4,950	7960 26'1"
0 mm 0'0"	kg lb			*7150 *16,450	*7150 *16,450	*7750 *16,800	4800 10,400	5250 11,250	3250 7,000	3800 8,200	2400 5,150	*3000 *6,550	2300 5,000	7780 25'5"
-1500 mm -5'0"	kg lb	*5400 *12,050	*5400 *12,050	*9700 *22,100	8600 18,450	7950 17,050	4700 10,150	5150 11,100	3200 6,850			*3600 *7,950	2500 5,450	7280 23'10"
-3000 mm -10'0"	kg lb	*8700 *19,450	*8700 *19,450	*11,400 *24,650	8650 18,600	*7750 *16,700	4700 10,150	5150 11,150	3200 6,900			4750 10,500	2950 6,550	6400 20'10"
-4500 mm -15'0"	kg lb			*9100 *19,350	8900 19,200	*6150 *12,950	4850 10,500					*5450 *12,000	4350 9,800	4920 15'9"



ISO 10567:2007



* Indicates that the load is limited by hydraulic lifting capacity rather than tipping load. The above loads are in compliance with hydraulic excavator lift capacity standard ISO 10567:2007. They do not exceed 87% of hydraulic lifting capacity or 75% of tipping load. Weight of all lifting accessories must be deducted from the above lifting capacities. Lifting capacities are based on the machine standing on a firm, uniform supporting surface. The use of a work tool attachment point to handle/lift objects, could affect the machine lift performance.

Lift capacity stays with ±5% for all available track shoes.

Always refer to the appropriate Operation and Maintenance Manual for specific product information.

317 Hydraulic Excavator Specifications

Reach Boom Lift Capacities – Counterweight: 3.77 mt (8,311 lb) – without Bucket

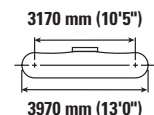
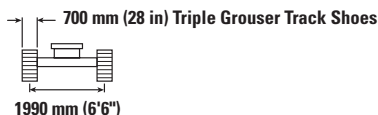

Reach mm ft/in	kg lb	1500 mm/5'0"		3000 mm/10'0"		4500 mm/15'0"		6000 mm/20'0"		7500 mm/25'0"		mm ft/in		
7500 mm 25'0"	kg lb											*2700 *6,050	*2700 *6,050	5380 17'2"
6000 mm 20'0"	kg lb							*3650 *7,550	*3650 *7,550			*2450 *5,400	*2450 *5,400	6670 21'7"
4500 mm 15'0"	kg lb							*3900 *8,500	3750 8,050			*2400 *5,250	*2400 *5,250	7440 24'3"
3000 mm 10'0"	kg lb			*7500 *15,950	*7500 *15,950	*5300 *11,450	*5300 *11,450	*4500 *9,700	3600 7,750	*3600 *7,100	2600 5,500	*2450 *5,400	2400 5,250	7850 25'8"
1500 mm 5'0"	kg lb			*8250 *19,750	*8250 *19,750	*6750 *14,550	5150 11,050	*5150 *11,200	3450 7,400	3900 8,400	2500 5,350	*2650 *5,800	2300 5,000	7960 26'1"
0 mm 0'0"	kg lb			*7150 *16,450	*7150 *16,450	*7750 *16,800	4900 10,500	5300 11,400	3300 7,100	3850 8,300	2450 5,250	*3000 *6,550	2300 5,100	7780 25'5"
-1500 mm -5'0"	kg lb	*5400 *12,050	*5400 *12,050	*9700 *22,100	8700 18,650	8050 17,300	4750 10,250	5200 11,250	3250 6,950			*3600 *7,950	2500 5,500	7280 23'10"
-3000 mm -10'0"	kg lb	*8700 *19,450	*8700 *19,450	*11,400 *24,650	8750 18,850	*7750 *16,700	4800 10,250	5250 11,250	3250 7,000			4800 10,650	3000 6,650	6400 20'10"
-4500 mm -15'0"	kg lb			*9100 19,350	9000 19,350	*6150 *12,950	4900 10,600					*5450 *12,000	4400 9,900	4920 15'9"

Reach Boom Lift Capacities – Counterweight: 3.77 mt (8,311 lb) – without Bucket

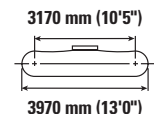
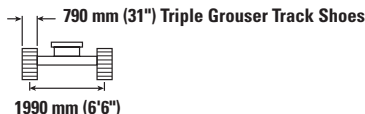

Reach mm ft/in	kg lb	1500 mm/5'0"		3000 mm/10'0"		4500 mm/15'0"		6000 mm/20'0"		7500 mm/25'0"		mm ft/in		
7500 mm 25'0"	kg lb											*2700 *6,050	*2700 *6,050	5380 17'2"
6000 mm 20'0"	kg lb							*3650 *7,550	*3650 *7,550			*2450 *5,400	*2450 *5,400	6670 21'7"
4500 mm 15'0"	kg lb							*3900 *8,500	3800 8,200			*2400 *5,250	*2400 *5,250	7440 24'3"
3000 mm 10'0"	kg lb			*7500 *15,950	*7500 *15,950	*5300 *11,450	*5300 *11,450	*4500 *9,700	3650 7,900	*3600 *7,100	2600 5,600	*2450 *5,400	2450 5,350	7850 25'8"
1500 mm 5'0"	kg lb			*8250 *19,750	*8250 *19,750	*6750 *14,550	5250 11,250	*5150 *11,200	3500 7,550	4000 8,600	2550 5,450	*2650 *5,800	2350 5,100	7960 26'1"
0 mm 0'0"	kg lb			*7150 *16,450	*7150 *16,450	*7750 *16,800	4950 10,700	5400 11,650	3350 7,250	3950 *8,350	2500 5,350	*3000 *6,550	2350 5,200	7780 25'5"
-1500 mm -5'0"	kg lb	*5400 *12,050	*5400 *12,050	*9700 *22,100	8850 19,000	*8100 *17,550	4850 10,450	5350 11,450	3300 7,100			*3600 *7,950	2550 5,650	7280 23'10"
-3000 mm -10'0"	kg lb	*8700 *19,450	*8700 *19,450	*11,400 *24,650	8950 19,200	*7750 *16,700	4850 10,450	5350 11,500	3300 7,150			4900 10,850	3050 6,750	6400 20'10"
-4500 mm -15'0"	kg lb			*9100 *19,350	*9100 *19,350	*6150 *12,950	5000 10,800					*5450 *12,000	4450 10,100	4920 15'9"



ISO 10567:2007



* Indicates that the load is limited by hydraulic lifting capacity rather than tipping load. The above loads are in compliance with hydraulic excavator lift capacity standard ISO 10567:2007. They do not exceed 87% of hydraulic lifting capacity or 75% of tipping load. Weight of all lifting accessories must be deducted from the above lifting capacities. Lifting capacities are based on the machine standing on a firm, uniform supporting surface. The use of a work tool attachment point to handle/lift objects, could affect the machine lift performance.

Lift capacity stays with ±5% for all available track shoes.

Always refer to the appropriate Operation and Maintenance Manual for specific product information.

317 Hydraulic Excavator Specifications

Variable Angle Boom Lift Capacities – Counterweight: 3.77 mt (8,311 lb) – without Bucket

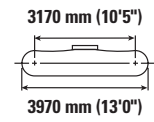
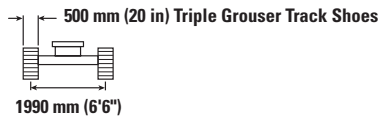
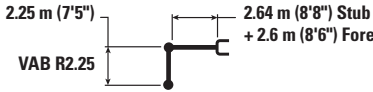

		3000 mm/10'0"		4500 mm/15'0"		6000 mm/20'0"				mm ft/in
7500 mm 25'0"	kg lb	*5950 *13,200	*5950 *13,200	*4000	*4000			*3900 *8,700	*3900 *8,700	4530 14'3"
6000 mm 20'0"	kg lb	*5400 *11,900	*5400 *11,900	*5550 *12,050	*5550 *12,050	*3300	*3300	*3300 *7,250	*3300 *7,250	6010 19'5"
4500 mm 15'0"	kg lb	*7800 *16,200	*7800 *16,200	*6000 *12,950	5500 11,850	*4600 *9,900	3550 7,600	*3100 *6,800	2850 6,250	6860 22'4"
3000 mm 10'0"	kg lb			*7250 *15,500	5100 11,050	*4900 *10,550	3400 7,300	*3100 *6,750	2500 5,550	7300 23'10"
1500 mm 5'0"	kg lb			8050 17,300	4750 10,250	5250 11,250	3250 6,950	*3250 *7,100	2400 5,250	7420 24'3"
0 mm 0'0"	kg lb			*7550 *16,400	4600 9,850	5100 11,000	3150 6,750	*3550 *7,800	2450 5,400	7220 23'8"
-1500 mm -5'0"	kg lb	*7100 *15,600	*7100 *15,600	*6150 *13,250	4550 9,800	*4450 *9,500	3100 6,700	*3400 *7,450	2750 6,050	6680 21'10"

Variable Angle Boom Lift Capacities – Counterweight: 3.77 mt (8,311 lb) – without Bucket

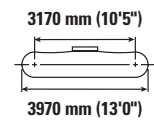
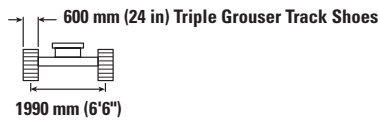
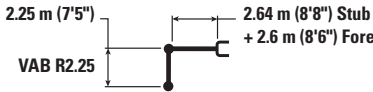

		3000 mm/10'0"		4500 mm/15'0"		6000 mm/20'0"				mm ft/in
7500 mm 25'0"	kg lb	*5950 *13,200	*5950 *13,200	*4000	*4000			*3900 *8,700	*3900 *8,700	4530 14'3"
6000 mm 20'0"	kg lb	*5400 *11,900	*5400 *11,900	*5550 *12,050	*5550 *12,050	*3300	*3300	*3300 *7,250	*3300 *7,250	6010 19'5"
4500 mm 15'0"	kg lb	*7800 *16,200	*7800 *16,200	*6000 *12,950	5550 11,950	*4600 *9,900	3550 7,650	*3100 *6,800	2850 6,350	6860 22'4"
3000 mm 10'0"	kg lb			*7250 *15,500	5150 11,150	*4900 *10,550	3450 7,350	*3100 *6,750	2550 5,600	7300 23'10"
1500 mm 5'0"	kg lb			*8100 17,500	4800 10,400	5300 11,350	3250 7,050	*3250 *7,100	2450 5,350	7420 24'3"
0 mm 0'0"	kg lb			*7550 *16,400	4650 10,000	5150 11,100	3150 6,800	*3550 *7,800	2500 5,450	7220 23'8"
-1500 mm -5'0"	kg lb	*7100 *15,600	*7100 *15,600	*6150 *13,250	4600 9,950	*4450 *9,500	3150 6,800	*3400 *7,450	2750 6,100	6680 21'10"



ISO 10567:2007



* Indicates that the load is limited by hydraulic lifting capacity rather than tipping load. The above loads are in compliance with hydraulic excavator lift capacity standard ISO 10567:2007. They do not exceed 87% of hydraulic lifting capacity or 75% of tipping load. Weight of all lifting accessories must be deducted from the above lifting capacities. Lifting capacities are based on the machine standing on a firm, uniform supporting surface. The use of a work tool attachment point to handle/lift objects, could affect the machine lift performance.

Lift capacity stays with ±5% for all available track shoes.

Always refer to the appropriate Operation and Maintenance Manual for specific product information.

Maximum length of VAB.

317 Hydraulic Excavator Specifications

Variable Angle Boom Lift Capacities – Counterweight: 3.77 mt (8,311 lb)– without Bucket

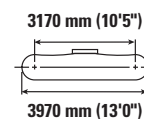
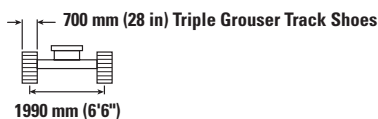
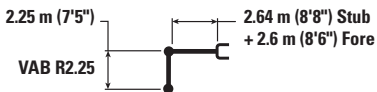

		3000 mm/10'0"		4500 mm/15'0"		6000 mm/20'0"				mm ft/in
7500 mm 25'0"	kg lb	*5950 *13,200	*5950 *13,200	*4000	*4000			*3900 *8,700	*3900 *8,700	4530 14'3"
6000 mm 20'0"	kg lb	*5400 *11,900	*5400 *11,900	*5550 *12,050	*5550 *12,050	*3300	*3300	*3300 *7,250	*3300 *7,250	6010 19'5"
4500 mm 15'0"	kg lb	*7800 *16,200	*7800 *16,200	*6000 *12,950	5600 12,050	*4600 *9,900	3600 7,750	*3100 *6,800	2900 6,400	6860 22'4"
3000 mm 10'0"	kg lb			*7250 *15,500	5250 11,250	*4900 *10,550	3450 7,450	*3100 *6,750	2550 5,650	7300 23'10"
1500 mm 5'0"	kg lb			*8100 *17,600	4900 10,500	5350 11,500	3300 7,100	*3250 *7,100	2450 5,400	7420 24'3"
0 mm 0'0"	kg lb			*7550 *16,400	4700 10,100	5250 11,250	3200 6,900	*3550 *7,800	2500 5,550	7220 23'8"
-1500 mm -5'0"	kg lb	*7100 *15,600	*7100 *15,600	*6150 *13,250	4700 10,050	*4450 *9,500	3200 6,850	*3400 *7,450	2800 6,150	6680 21'10"

Variable Angle Boom Lift Capacities – Counterweight: 3.77 mt (8,311 lb) – without Bucket

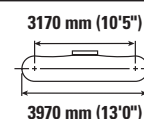
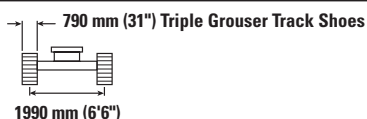
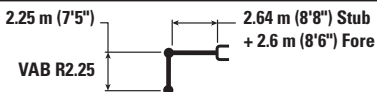

		3000 mm/10'0"		4500 mm/15'0"		6000 mm/20'0"				mm ft/in
7500 mm 25'0"	kg lb	*5950 *13,200	*5950 *13,200	*4000	*4000			*3900 *8,700	*3900 *8,700	4530 14'3"
6000 mm 20'0"	kg lb	*5400 *11,900	*5400 *11,900	*5550 *12,050	*5550 *12,050	*3300	*3300	*3300 *7,250	*3300 *7,250	6010 19'5"
4500 mm 15'0"	kg lb	*7800 *16,200	*7800 *16,200	*6000 *12,950	5700 12,250	*4600 *9,900	3650 7,900	*3100 *6,800	2950 6,550	6860 22'4"
3000 mm 10'0"	kg lb			*7250 *15,500	5300 11,450	*4900 *10,550	3550 7,600	*3100 *6,750	2650 5,750	7300 23'10"
1500 mm 5'0"	kg lb			*8100 *17,600	4950 10,700	*5400 *11,550	3350 7,250	*3250 *7,100	2500 5,500	7420 24'3"
0 mm 0'0"	kg lb			*7550 *16,400	4800 10,300	5350 11,500	3250 7,050	*3550 *7,800	2600 5,650	7220 23'8"
-1500 mm -5'0"	kg lb	*7100 *15,600	*7100 *15,600	*6150 *13,250	4750 10,250	*4450 *9,500	3250 7,000	*3400 *7,450	2850 6,300	6680 21'10"



ISO 10567:2007



* Indicates that the load is limited by hydraulic lifting capacity rather than tipping load. The above loads are in compliance with hydraulic excavator lift capacity standard ISO 10567:2007. They do not exceed 87% of hydraulic lifting capacity or 75% of tipping load. Weight of all lifting accessories must be deducted from the above lifting capacities. Lifting capacities are based on the machine standing on a firm, uniform supporting surface. The use of a work tool attachment point to handle/lift objects, could affect the machine lift performance.

Lift capacity stays with ±5% for all available track shoes.

Always refer to the appropriate Operation and Maintenance Manual for specific product information.

Maximum length of VAB.

317 Hydraulic Excavator Specifications

Variable Angle Boom Lift Capacities – Counterweight: 3.77 mt (8,311 lb) – without Bucket

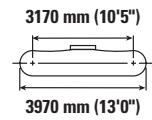
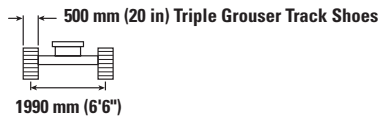
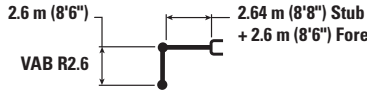

Boom Length	Unit	1500 mm/5'0"		3000 mm/10'0"		4500 mm/15'0"		6000 mm/20'0"		7500 mm/25'0"		mm ft/in		
		kg lb	kg lb	kg lb	kg lb	kg lb	kg lb	kg lb	kg lb	kg lb	kg lb	kg lb	mm ft/in	
9000 mm 30'0"	kg lb	*13,600	*13,600									*5100 *12,900	*5100 *12,900	2250 5'5"
7500 mm 25'0"	kg lb			*5050 *11,250	*5050 *11,250	*4500 *9,300	*4500 *9,300					*3200 *7,100	*3200 *7,100	5050 16'1"
6000 mm 20'0"	kg lb			*4500 *9,950	*4500 *9,950	*4950 *10,850	*4950 *10,850	*4100 *8,250	3650 7,750			*2750 *6,050	*2750 *6,050	6410 20'9"
4500 mm 15'0"	kg lb			*5600 *11,950	*5600 *11,950	*5700 *12,300	5550 12,000	*4400 *9,500	3550 7,650			*2600 *5,750	*2600 *5,750	7210 23'6"
3000 mm 10'0"	kg lb					*6850 *14,600	5200 11,150	*4750 *10,150	3400 7,350	*3450 *5,750	2400 5,150	*2600 *5,700	2350 5,150	7640 25'0"
1500 mm 5'0"	kg lb					*8100 17,400	4800 10,350	*5200 *11,150	3250 6,950	3750 *8,000	2350 5,050	*2750 *5,950	2250 4,950	7750 25'4"
0 mm 0'0"	kg lb					*7750 *16,800	4600 9,850	5100 10,950	3100 6,700	*3500	2300	*3000 *6,550	2300 5,050	7560 24'9"
-1500 mm -5'0"	kg lb			*8200 *17,850	*8200 *17,850	*6550 *14,100	4500 9,750	*4800 *10,250	3100 6,600			*3400 *7,400	2500 5,550	7050 23'0"

Variable Angle Boom Lift Capacities – Counterweight: 3.77 mt (8,311 lb) – without Bucket

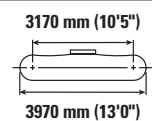
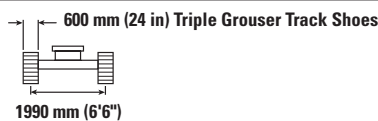
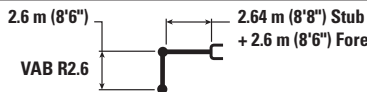

Boom Length	Unit	1500 mm/5'0"		3000 mm/10'0"		4500 mm/15'0"		6000 mm/20'0"		7500 mm/25'0"		mm ft/in		
		kg lb	kg lb	kg lb	kg lb	kg lb	kg lb	kg lb	kg lb	kg lb	kg lb	kg lb	mm ft/in	
9000 mm 30'0"	kg lb	*13,600	*13,600									*5100 *12,900	*5100 *12,900	2250 5'5"
7500 mm 25'0"	kg lb			*5050 *11,250	*5050 *11,250	*4500 *9,300	*4500 *9,300					*3200 *7,100	*3200 *7,100	5050 16'1"
6000 mm 20'0"	kg lb			*4500 *9,950	*4500 *9,950	*4950 *10,850	*4950 *10,850	*4100 *8,250	3650 7,800			*2750 *6,050	*2750 *6,050	6410 20'9"
4500 mm 15'0"	kg lb			*5600 *11,950	*5600 *11,950	*5700 *12,300	5600 12,100	*4400 *9,500	3600 7,750			*2600 *5,750	*2600 *5,750	7210 23'6"
3000 mm 10'0"	kg lb					*6850 *14,600	5250 11,300	*4750 *10,150	3450 7,400	*3450 *5,750	2450 5,250	*2600 *5,700	2400 5,200	7640 25'0"
1500 mm 5'0"	kg lb					*8100 *17,450	4850 10,450	*5200 *11,150	3300 7,050	3800 *8,000	2400 5,100	*2750 *5,950	2300 5,000	7750 25'4"
0 mm 0'0"	kg lb					*7750 *16,800	4650 9,950	5150 11,100	3150 6,800	*3500	2350	*3000 *6,550	2300 5,100	7560 24'9"
-1500 mm -5'0"	kg lb			*8200 *17,850	*8200 *17,850	*6550 *14,100	4600 9,850	*4800 *10,250	3100 6,700			*3400 *7,400	2550 5,600	7050 23'0"



ISO 10567:2007



* Indicates that the load is limited by hydraulic lifting capacity rather than tipping load. The above loads are in compliance with hydraulic excavator lift capacity standard ISO 10567:2007. They do not exceed 87% of hydraulic lifting capacity or 75% of tipping load. Weight of all lifting accessories must be deducted from the above lifting capacities. Lifting capacities are based on the machine standing on a firm, uniform supporting surface. The use of a work tool attachment point to handle/lift objects, could affect the machine lift performance.

Lift capacity stays with ±5% for all available track shoes.

Always refer to the appropriate Operation and Maintenance Manual for specific product information.

Maximum length of VAB.

317 Hydraulic Excavator Specifications

Variable Angle Boom Lift Capacities – Counterweight: 3.77 mt (8,311 lb) – without Bucket

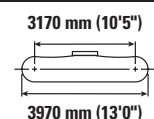

Boom Length	Unit	1500 mm/5'0"		3000 mm/10'0"		4500 mm/15'0"		6000 mm/20'0"		7500 mm/25'0"		mm ft/in		
		kg lb	kg lb	kg lb	kg lb	kg lb	kg lb	kg lb	kg lb	kg lb	kg lb	kg lb	mm ft/in	
9000 mm 30'0"	kg lb	*13,600	*13,600									*5100 *12,900	*5100 *12,900	2250 5'5"
7500 mm 25'0"	kg lb			*5050 *11,250	*5050 *11,250	*4500 *9,300	*4500 *9,300					*3200 *7,100	*3200 *7,100	5050 16'1"
6000 mm 20'0"	kg lb			*4500 *9,950	*4500 *9,950	*4950 *10,850	*4950 *10,850	*4100 *8,250	3700 7,900			*2750 *6,050	*2750 *6,050	6410 20'9"
4500 mm 15'0"	kg lb			*5600 *11,950	*5600 *11,950	*5700 *12,300	5700 12,200	*4400 *9,500	3650 7,800			*2600 *5,750	*2600 *5,750	7210 23'6"
3000 mm 10'0"	kg lb					*6850 *14,600	5300 11,400	*4750 *10,150	3500 7,500	*3450 *5,750	2500 5,300	*2600 *5,700	2400 5,300	7640 25'0"
1500 mm 5'0"	kg lb					*8100 *17,450	4900 10,600	*5200 *11,150	3300 7,100	*3850 *8,000	2400 5,150	*2750 *5,950	2300 5,050	7750 25'4"
0 mm 0'0"	kg lb					*7750 *16,800	4700 10,100	5200 11,250	3200 6,850	*3500	2350	*3000 *6,550	2350 5,150	7560 24'9"
-1500 mm -5'0"	kg lb			*8200 *17,850	*8200 *17,850	*6550 *14,100	4650 9,950	*4800 *10,250	3150 6,800			*3400 *7,400	2600 5,700	7050 23'0"

Variable Angle Boom Lift Capacities – Counterweight: 3.77 mt (8,311 lb) – without Bucket

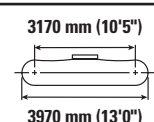
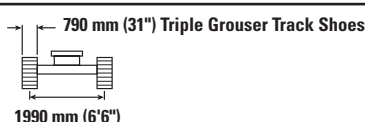
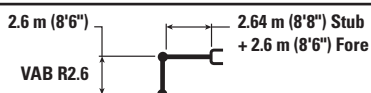

Boom Length	Unit	1500 mm/5'0"		3000 mm/10'0"		4500 mm/15'0"		6000 mm/20'0"		7500 mm/25'0"		mm ft/in		
		kg lb	kg lb	kg lb	kg lb	kg lb	kg lb	kg lb	kg lb	kg lb	kg lb	kg lb	mm ft/in	
9000 mm 30'0"	kg lb	*13,600	*13,600									*5100 *12,900	*5100 *12,900	2250 5'5"
7500 mm 25'0"	kg lb			*5050 *11,250	*5050 *11,250	*4500 *9,300	*4500 *9,300					*3200 *7,100	*3200 *7,100	5050 16'1"
6000 mm 20'0"	kg lb			*4500 *9,950	*4500 *9,950	*4950 *10,850	*4950 *10,850	*4100 *8,250	3750 8,050			*2750 *6,050	*2750 *6,050	6410 20'9"
4500 mm 15'0"	kg lb			*5600 *11,950	*5600 *11,950	*5700 *12,300	*5700 *12,300	*4400 *9,500	3700 7,950			*2600 *5,750	*2600 *5,750	7210 23'6"
3000 mm 10'0"	kg lb					*6850 *14,600	5400 11,600	*4750 *10,150	3550 7,650	*3450 *5,750	2550 5,400	*2600 *5,700	2450 5,400	7640 25'0"
1500 mm 5'0"	kg lb					*8100 *17,450	5000 10,800	*5200 *11,150	3400 7,250	*3850 *8,000	2450 5,300	*2750 *5,950	2350 5,150	7750 25'4"
0 mm 0'0"	kg lb					*7750 *16,800	4800 10,300	5350 11,450	3250 7,000	*3500	2400	*3000 *6,550	2400 5,250	7560 24'9"
-1500 mm -5'0"	kg lb			*8200 *17,850	*8200 *17,850	*6550 *14,100	4750 10,150	*4800 *10,250	3200 6,900			*3400 *7,400	2650 5,800	7050 23'0"



ISO 10567:2007



* Indicates that the load is limited by hydraulic lifting capacity rather than tipping load. The above loads are in compliance with hydraulic excavator lift capacity standard ISO 10567:2007. They do not exceed 87% of hydraulic lifting capacity or 75% of tipping load. Weight of all lifting accessories must be deducted from the above lifting capacities. Lifting capacities are based on the machine standing on a firm, uniform supporting surface. The use of a work tool attachment point to handle/lift objects, could affect the machine lift performance.

Lift capacity stays with ±5% for all available track shoes.

Always refer to the appropriate Operation and Maintenance Manual for specific product information.

Maximum length of VAB.

317 Hydraulic Excavator Specifications

Reach Boom Lift Capacities – Counterweight: 3.77 mt (8,311 lb) – without Bucket – Blade Up

2500 mm (8'2") Blade

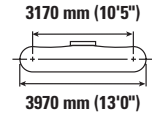
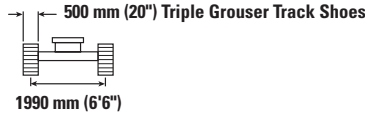
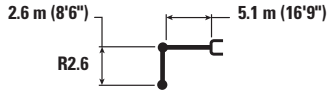

		1500 mm/5'0"		3000 mm/10'0"		4500 mm/15'0"		6000 mm/20'0"		7500 mm/25'0"		mm ft/in		
7500 mm 25'0"	kg lb					*7,700	*7,700					*3350 *7,450	*3350 *7,450	4770 15'1"
6000 mm 20'0"	kg lb							*3600 *6,650	*3600 *6,650			*2950 *6,450	*2950 *6,450	6190 20'0"
4500 mm 15'0"	kg lb					*4650 *10,050	*4650 *10,050	*4300 *9,450	3800 8,150			*2850 *6,200	*2850 *6,200	7020 22'10"
3000 mm 10'0"	kg lb					*5900 *12,700	5500 11,900	*4850 *10,500	3650 7,850			*2900 *6,300	2650 5,850	7450 24'4"
1500 mm 5'0"	kg lb					*7250 *15,600	5200 11,200	5300 11,400	3500 7,550	*3500	2550	*3050 *6,750	2550 5,550	7560 24'9"
0 mm 0'0"	kg lb					7950 17,100	5000 10,750	5150 11,100	3400 7,300			*3450 *7,600	2600 5,650	7370 24'2"
-1500 mm -5'0"	kg lb	*5650 *12,650	*5650 *12,650	*10 050 *22,950	8950 19,250	7900 16,900	4900 10,600	5100 11,000	3350 7,200			*4200 *9,300	2850 6,250	6850 22'4"
-3000 mm -10'0"	kg lb	*9900 *22,300	*9900 *22,300	*10 750 *23,250	9100 19,550	*7450 *16,050	4950 10,700					5300 11,800	3500 7,750	5900 19'2"
-4500 mm -15'0"	kg lb			*7750 *16,400	*7750 *16,400							*5450 *11,900	*5450 *11,900	4240 13'6"

Reach Boom Lift Capacities – Counterweight: 3.77 mt (8,311 lb) – without Bucket – Blade Up

2600 mm (8'6") Blade

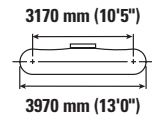
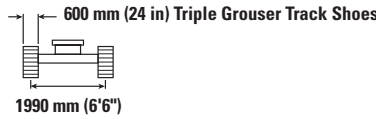
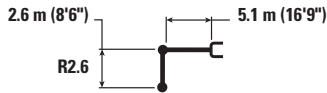

		1500 mm/5'0"		3000 mm/10'0"		4500 mm/15'0"		6000 mm/20'0"		7500 mm/25'0"		mm ft/in		
7500 mm 25'0"	kg lb					*7,700	*7,700					*3350 *7,450	*3350 *7,450	4770 15'1"
6000 mm 20'0"	kg lb							*3600 *6,650	*3600 *6,650			*2950 *6,450	*2950 *6,450	6190 20'0"
4500 mm 15'0"	kg lb					*4650 *10,050	*4650 *10,050	*4300 *9,450	3850 8,200			*2850 *6,200	*2850 *6,200	7020 22'10"
3000 mm 10'0"	kg lb					*5900 *12,700	5600 12,000	*4850 *10,500	3700 7,950			*2900 *6,300	2700 5,900	7450 24'4"
1500 mm 5'0"	kg lb					*7250 *15,600	5250 11,300	5350 11,500	3550 7,650	*3500	2600	*3050 *6,750	2550 5,650	7560 24'9"
0 mm 0'0"	kg lb					*8050 17,250	5050 10,850	5250 11,250	3450 7,400			*3450 *7,600	2600 5,750	7370 24'2"
-1500 mm -5'0"	kg lb	*5650 *12,650	*5650 *12,650	*10 050 *22,950	9050 19,450	7950 17,100	4950 10,700	5200 11,150	3400 7,300			*4200 *9,300	2850 6,300	6850 22'4"
-3000 mm -10'0"	kg lb	*9900 *22,300	*9900 *22,300	*10 750 *23,250	9200 19,750	*7450 *16,050	5000 10,800					*5350 *11,800	3550 7,800	5900 19'2"
-4500 mm -15'0"	kg lb			*7750 *16,400	*7750 *16,400							*5450 *11,900	*5450 *11,900	4240 13'6"



ISO 10567:2007



* Indicates that the load is limited by hydraulic lifting capacity rather than tipping load. The above loads are in compliance with hydraulic excavator lift capacity standard ISO 10567:2007. They do not exceed 87% of hydraulic lifting capacity or 75% of tipping load. Weight of all lifting accessories must be deducted from the above lifting capacities. Lifting capacities are based on the machine standing on a firm, uniform supporting surface. The use of a work tool attachment point to handle/lift objects, could affect the machine lift performance.

Lift capacity stays with ±5% for all available track shoes.

Always refer to the appropriate Operation and Maintenance Manual for specific product information.

317 Hydraulic Excavator Specifications

Reach Boom Lift Capacities – Counterweight: 3.77 mt (8,311 lb) – without Bucket – Blade Up

2700 mm (8'10") Blade

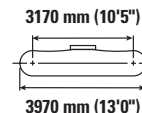
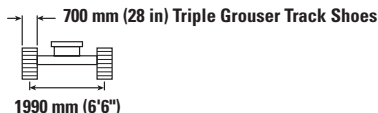

Reach Boom	1500 mm/5'0"		3000 mm/10'0"		4500 mm/15'0"		6000 mm/20'0"		7500 mm/25'0"		mm ft/in		
	kg lb	kg lb	kg lb	kg lb	kg lb	kg lb	kg lb	kg lb	kg lb	kg lb	kg lb	mm ft/in	
7500 mm 25'0"					*7,700	*7,700					*3350 *7,450	*3350 *7,450	4770 15'1"
6000 mm 20'0"							*3600 *6,650	*3600 *6,650			*2950 *6,450	*2950 *6,450	6190 20'0"
4500 mm 15'0"					*4650 *10,050	*4650 *10,050	*4300 *9,450	3850 8,300			*2850 *6,200	*2850 *6,200	7020 22'10"
3000 mm 10'0"			*8900 *18,900	*8900 *18,900	*5900 *12,700	5650 12,150	*4850 *10,500	3750 8,050			*2900 *6,300	2700 5,950	7450 24'4"
1500 mm 5'0"					*7250 *15,600	5300 11,450	5400 11,650	3600 7,700	*3500 2650		*3050 *6,750	2600 5,700	7560 24'9"
0 mm 0'0"			*6200 *14,200	*6200 *14,200	*8050 *17,400	5100 11,000	5300 11,400	3500 7,500			*3450 *7,600	2650 5,800	7370 24'2"
-1500 mm -5'0"	*5650 *12,650	*5650 *12,650	*10 050 *22,950	9200 19,700	8050 17,300	5050 10,850	5250 11,250	3450 7,400			*4200 *9,300	2900 6,400	6850 22'4"
-3000 mm -10'0"	*9900 *22,300	*9900 *22,300	*10 750 *23,250	9300 20,000	*7450 *16,050	5100 10,950					*5350 *11,800	3550 7,900	5900 19'2"
-4500 mm -15'0"			*7750 *16,400	*7750 *16,400							*5450 *11,900	*5450 *11,900	4240 13'6"

Reach Boom Lift Capacities – Counterweight: 3.77 mt (8,311 lb) – without Bucket – Blade Up

2700 mm (8'10") Blade

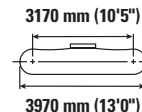
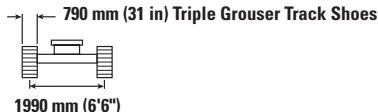
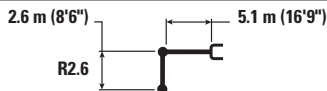

Reach Boom	1500 mm/5'0"		3000 mm/10'0"		4500 mm/15'0"		6000 mm/20'0"		7500 mm/25'0"		mm ft/in		
	kg lb	kg lb	kg lb	kg lb	kg lb	kg lb	kg lb	kg lb	kg lb	kg lb	kg lb	mm ft/in	
7500 mm 25'0"					*7,700	*7,700					*3350 *7,450	*3350 *7,450	4770 15'1"
6000 mm 20'0"							*3600 *6,650	*3600 *6,650			*2950 *6,450	*2950 *6,450	6190 20'0"
4500 mm 15'0"					*4650 *10,050	*4650 *10,050	*4300 *9,450	3950 8,450			*2850 *6,200	*2850 *6,200	7020 22'10"
3000 mm 10'0"			*8900 *18,900	*8900 *18,900	*5900 *12,700	5750 12,350	*4850 *10,500	3800 8,200			*2900 *6,300	2750 6,100	7450 24'4"
1500 mm 5'0"					*7250 *15,600	5400 11,650	*5450 *11,850	3650 7,850	*3500 2700		*3050 *6,750	2650 5,800	7560 24'9"
0 mm 0'0"			*6200 *14,200	*6200 *14,200	*8050 *17,400	5200 11,200	5400 11,600	3500 7,600			*3450 *7,600	2700 5,900	7370 24'2"
-1500 mm -5'0"	*5650 *12,650	*5650 *12,650	*10 050 *22,950	9350 20,050	*8150 *17,650	5150 11,050	5350 11,500	3500 7,500			*4200 *9,300	2950 6,500	6850 22'4"
-3000 mm -10'0"	*9900 *22,300	*9900 *22,300	*10 750 *23,250	9450 20,350	*7450 *16,050	5150 11,150					*5350 *11,800	3650 8,050	5900 19'2"
-4500 mm -15'0"			*7750 *16,400	*7750 *16,400							*5450 *11,900	*5450 *11,900	4240 13'6"



ISO 10567:2007



* Indicates that the load is limited by hydraulic lifting capacity rather than tipping load. The above loads are in compliance with hydraulic excavator lift capacity standard ISO 10567:2007. They do not exceed 87% of hydraulic lifting capacity or 75% of tipping load. Weight of all lifting accessories must be deducted from the above lifting capacities. Lifting capacities are based on the machine standing on a firm, uniform supporting surface. The use of a work tool attachment point to handle/lift objects, could affect the machine lift performance.

Lift capacity stays with ±5% for all available track shoes.

Always refer to the appropriate Operation and Maintenance Manual for specific product information.

317 Hydraulic Excavator Specifications

Reach Boom Lift Capacities – Counterweight: 3.77 mt (8,311 lb) – without Bucket – Blade Up

2500 mm (8'2") Blade

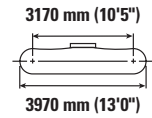
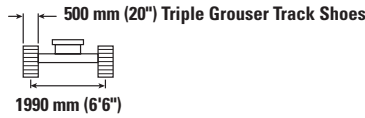
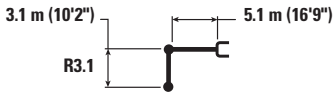

		1500 mm/5'0"		3000 mm/10'0"		4500 mm/15'0"		6000 mm/20'0"		7500 mm/25'0"		mm ft/in		
7500 mm 25'0"	kg lb											*2700 *6,050	*2700 *6,050	5380 17'2"
6000 mm 20'0"	kg lb							*3650 *7,550	*3650 *7,550			*2450 *5,400	*2450 *5,400	6670 21'7"
4500 mm 15'0"	kg lb							*3900 *8,500	*3900 8,400			*2400 *5,250	*2400 *5,250	7440 24'3"
3000 mm 10'0"	kg lb			*7500 *15,950	*7500 *15,950	*5300 *11,450	*5300 *11,450	*4500 *9,700	3750 8,100	*3600 *7,100	2700 5,750	*2450 *5,400	*2450 *5,400	7850 25'8"
1500 mm 5'0"	kg lb			*8250 *19,750	*8250 *19,750	*6750 *14,550	5350 11,550	*5150 *11,200	3600 7,700	3900 8,400	2600 5,600	*2650 *5,800	2400 5,250	7960 26'1"
0 mm 0'0"	kg lb			*7150 *16,450	*7150 *16,450	*7750 *16,800	5100 10,950	5300 11,350	3450 7,450	3850 8,250	2550 5,500	*3000 *6,550	2450 5,350	7780 25'5"
-1500 mm -5'0"	kg lb	*5400 *12,050	*5400 *12,050	*9700 *22,100	9050 19,450	8000 17,200	5000 10,700	5200 11,150	3400 7,300			*3600 *7,950	2650 5,800	7280 23'10"
-3000 mm -10'0"	kg lb	*8700 *19,450	*8700 *19,450	*11,400 *24,650	9150 19,650	*7750 *16,700	5000 10,750	5200 11,200	3400 7,300			4800 10,600	3150 6,950	6400 20'10"
-4500 mm -15'0"	kg lb			*9100 *19,350	*9100 *19,350	*6150 *12,950	5150 11,100					*5450 *12,000	4600 10,350	4920 15'9"

Reach Boom Lift Capacities – Counterweight: 3.77 mt (8,311 lb) – without Bucket – Blade Up

2600 mm (8'6") Blade

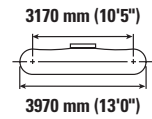
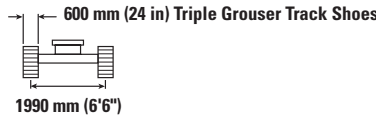
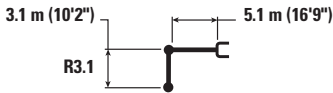

		1500 mm/5'0"		3000 mm/10'0"		4500 mm/15'0"		6000 mm/20'0"		7500 mm/25'0"		mm ft/in		
7500 mm 25'0"	kg lb											*2700 *6,050	*2700 *6,050	5380 17'2"
6000 mm 20'0"	kg lb							*3650 *7,550	*3650 *7,550			*2450 *5,400	*2450 *5,400	6670 21'7"
4500 mm 15'0"	kg lb							*3900 *8,500	3850 8,300			*2400 *5,250	*2400 *5,250	7440 24'3"
3000 mm 10'0"	kg lb			*7500 *15,950	*7500 *15,950	*5300 *11,450	*5300 *11,450	*4500 *9,700	3700 8,000	*3600 *7,100	2650 5,700	*2450 *5,400	*2450 *5,400	7850 25'8"
1500 mm 5'0"	kg lb			*8250 *19,750	*8250 *19,750	*6750 *14,550	5300 11,400	*5150 *11,200	3550 7,650	3850 8,300	2600 5,550	*2650 *5,800	2350 5,200	7960 26'1"
0 mm 0'0"	kg lb			*7150 *16,450	*7150 *16,450	*7750 *16,800	5050 10,850	5200 11,200	3400 7,350	3800 8,150	2500 5,400	*3000 *6,550	2400 5,250	7780 25'5"
-1500 mm -5'0"	kg lb	*5400 *12,050	*5400 *12,050	*9700 *22,100	8950 19,250	7900 17,000	4900 10,600	5150 11,050	3350 7,200			*3600 *7,950	2600 5,700	7280 23'10"
-3000 mm -10'0"	kg lb	*8700 *19,450	*8700 *19,450	*11,400 *24,650	9050 19,450	*7750 *16,700	4950 10,600	5150 11,100	3350 7,250			4700 10,450	3100 6,850	6400 20'10"
-4500 mm -15'0"	kg lb			*9100 *19,350	*9100 *19,350	*6150 *12,950	5100 10,950					*5450 *12,000	4500 10,250	4920 15'9"



ISO 10567:2007



* Indicates that the load is limited by hydraulic lifting capacity rather than tipping load. The above loads are in compliance with hydraulic excavator lift capacity standard ISO 10567:2007. They do not exceed 87% of hydraulic lifting capacity or 75% of tipping load. Weight of all lifting accessories must be deducted from the above lifting capacities. Lifting capacities are based on the machine standing on a firm, uniform supporting surface. The use of a work tool attachment point to handle/lift objects, could affect the machine lift performance.

Lift capacity stays with ±5% for all available track shoes.

Always refer to the appropriate Operation and Maintenance Manual for specific product information.

317 Hydraulic Excavator Specifications

Reach Boom Lift Capacities – Counterweight: 3.77 mt (8,311 lb) – without Bucket – Blade Up

2700 mm (8'10") Blade

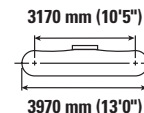
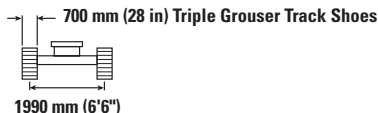
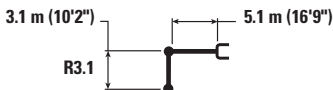

		1500 mm/5'0"		3000 mm/10'0"		4500 mm/15'0"		6000 mm/20'0"		7500 mm/25'0"		mm ft/in		
7500 mm 25'0"	kg lb											*2700 *6,050	*2700 *6,050	5380 17'2"
6000 mm 20'0"	kg lb							*3650 *7,550	*3650 *7,550			*2450 *5,400	*2450 *5,400	6670 21'7"
4500 mm 15'0"	kg lb							*3900 *8,500	3850 8,200			*2400 *5,250	*2400 *5,250	7440 24'3"
3000 mm 10'0"	kg lb			*7500 *15,950	*7500 *15,950	*5300 *11,450	*5300 *11,450	*4500 *9,700	3700 7,900	*3600 *7,100	2650 5,650	*2450 *5,400	2450 5,400	7850 25'8"
1500 mm 5'0"	kg lb			*8250 *19,750	*8250 *19,750	*6750 *14,550	5250 11,300	*5150 *11,200	3500 7,550	3800 8,200	2550 5,500	*2650 *5,800	2350 5,150	7960 26'1"
0 mm 0'0"	kg lb			*7150 *16,450	*7150 *16,450	*7750 *16,800	5000 10,700	5150 11,100	3400 7,250	3750 8,050	2500 5,350	*3000 *6,550	2350 5,200	7780 25'5"
-1500 mm -5'0"	kg lb	*5400 *12,050	*5400 *12,050	*9700 *22,100	8850 19,050	7850 16,800	4850 10,450	5100 10,900	3300 7,100			*3600 *7,950	2550 5,650	7280 23'10"
-3000 mm -10'0"	kg lb	*8700 *19,450	*8700 *19,450	*11,400 *24,650	8950 19,200	*7750 *16,700	4900 10,500	5100 10,950	3300 7,150			4650 10,350	3050 6,800	6400 20'10"
-4500 mm -15'0"	kg lb			*9100 *19,350	*9100 *19,350	*6150 *12,950	5050 10,850					*5450 *12,000	4450 10,100	4920 15'9"

Reach Boom Lift Capacities – Counterweight: 3.77 mt (8,311 lb) – without Bucket – Blade Up

2700 mm (8'10") Blade

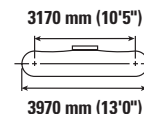
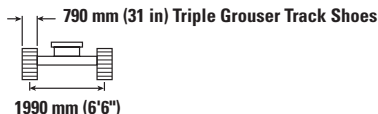

		1500 mm/5'0"		3000 mm/10'0"		4500 mm/15'0"		6000 mm/20'0"		7500 mm/25'0"		mm ft/in		
7500 mm 25'0"	kg lb											*2700 *6,050	*2700 *6,050	5380 17'2"
6000 mm 20'0"	kg lb							*3650 *7,550	*3650 *7,550			*2450 *5,400	*2450 *5,400	6670 21'7"
4500 mm 15'0"	kg lb							*3900 *8,500	*3900 *8,500			*2400 *5,250	*2400 *5,250	7440 24'3"
3000 mm 10'0"	kg lb			*7500 *15,950	*7500 *15,950	*5300 *11,450	*5300 *11,450	*4500 *9,700	3800 8,200	*3600 *7,100	2750 5,850	*2450 *5,400	*2450 *5,400	7850 25'8"
1500 mm 5'0"	kg lb			*8250 *19,750	*8250 *19,750	*6750 *14,550	5450 11,750	*5150 *11,200	3650 7,850	4000 8,550	2650 5,700	*2650 *5,800	2450 5,350	7960 26'1"
0 mm 0'0"	kg lb			*7150 *16,450	*7150 *16,450	*7750 *16,800	5200 11,150	5400 11,550	3500 7,550	3900 *8,350	2600 5,600	*3000 *6,550	2500 5,450	7780 25'5"
-1500 mm -5'0"	kg lb	*5400 *12,050	*5400 *12,050	*9700 *22,100	9250 19,800	*8100 17,550	5100 10,900	5300 11,400	3450 7,400			*3600 *7,950	2700 5,900	7280 23'10"
-3000 mm -10'0"	kg lb	*8700 *19,450	*8700 *19,450	*11,400 *24,650	9300 20,000	*7750 *16,700	5100 10,950	5300 11,450	3450 7,450			4850 10,800	3200 7,100	6400 20'10"
-4500 mm -15'0"	kg lb			*9100 *19,350	*9100 *19,350	*6150 *12,950	5250 11,300					*5450 *12,000	4650 10,550	4920 15'9"



ISO 10567:2007



* Indicates that the load is limited by hydraulic lifting capacity rather than tipping load. The above loads are in compliance with hydraulic excavator lift capacity standard ISO 10567:2007. They do not exceed 87% of hydraulic lifting capacity or 75% of tipping load. Weight of all lifting accessories must be deducted from the above lifting capacities. Lifting capacities are based on the machine standing on a firm, uniform supporting surface. The use of a work tool attachment point to handle/lift objects, could affect the machine lift performance.

Lift capacity stays with ±5% for all available track shoes.

Always refer to the appropriate Operation and Maintenance Manual for specific product information.

317 Hydraulic Excavator Specifications

Variable Angle Boom Lift Capacities – Counterweight 3.77 mt (8,311 lb) – without Bucket – Blade Up

2500 mm (8'2") Blade

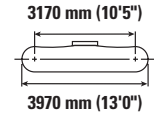
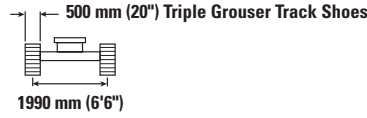
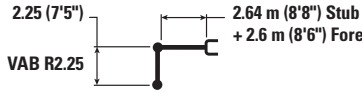

		3000 mm/10'0"		4500 mm/15'0"		6000 mm/20'0"				mm ft/in
7500 mm 25'0"	kg lb	*5950 *13,200	*5950 *13,200	*4000	*4000			*3900 *8,700	*3900 *8,700	4530 14'3"
6000 mm 20'0"	kg lb	*5400 *11,900	*5400 *11,900	*5550 *12,050	*5550 *12,050	*3300	*3300	*3300 *7,250	*3300 *7,250	6010 19'5"
4500 mm 15'0"	kg lb	*7800 *16,200	*7800 *16,200	*6000 *12,950	5700 12,300	*4600 *9,900	3700 7,900	*3100 *6,800	2950 6,550	6860 22'4"
3000 mm 10'0"	kg lb			*7250 *15,500	5350 11,500	*4900 *10,550	3550 7,600	*3100 *6,750	2650 5,800	7300 23'10"
1500 mm 5'0"	kg lb			8000 17,250	5000 10,700	5200 11,200	3400 7,250	*3250 *7,100	2500 5,500	7420 24'3"
0 mm 0'0"	kg lb			*7550 *16,400	4800 10,350	5100 10,950	3300 7,050	*3550 *7,800	2600 5,650	7220 23'8"
-1500 mm -5'0"	kg lb	*7100 *15,600	*7100 *15,600	*6150 *13,250	4800 10,300	*4450 *9,500	3250 7050	*3400 *7,450	2850 6,300	6680 21'10"

Variable Angle Boom Lift Capacities – Counterweight 3.77 mt (8,311 lb) – without Bucket – Blade Up

2600 mm (8'6") Blade

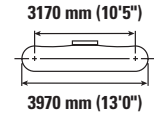
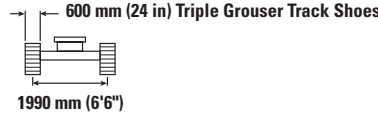
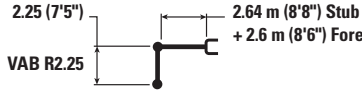

		3000 mm/10'0"		4500 mm/15'0"		6000 mm/20'0"				mm ft/in
7500 mm 25'0"	kg lb	*5950 *13,200	*5950 *13,200	*4000	*4000			*3900 *8,700	*3900 *8,700	4530 14'3"
6000 mm 20'0"	kg lb	*5400 *11,900	*5400 *11,900	*5550 *12,050	*5550 *12,050	*3300	*3300	*3300 *7,250	*3300 *7,250	6010 19'5"
4500 mm 15'0"	kg lb	*7800 *16,200	*7800 *16,200	*6000 *12,950	5750 12,400	*4600 *9,900	3700 8,000	*3100 *6,800	3000 6,600	6860 22'4"
3000 mm 10'0"	kg lb			*7250 *15,500	5400 11,600	*4900 *10,550	3550 7,700	*3100 *6,750	2650 5,850	7300 23'10"
1500 mm 5'0"	kg lb			8100 17,450	5050 10,850	5250 11,300	3400 7,350	*3250 *7,100	2550 5,600	7420 24'3"
0 mm 0'0"	kg lb			*7550 *16,400	4850 10,450	5150 11,050	3300 7,150	*3550 *7,800	2600 5,750	7220 23'8"
-1500 mm -5'0"	kg lb	*7100 *15,600	*7100 *15,600	*6150 *13,250	4850 10,400	*4450 *9,500	3300 7,100	*3400 *7,450	2900 6,400	6680 21'10"



ISO 10567:2007



* Indicates that the load is limited by hydraulic lifting capacity rather than tipping load. The above loads are in compliance with hydraulic excavator lift capacity standard ISO 10567:2007. They do not exceed 87% of hydraulic lifting capacity or 75% of tipping load. Weight of all lifting accessories must be deducted from the above lifting capacities. Lifting capacities are based on the machine standing on a firm, uniform supporting surface. The use of a work tool attachment point to handle/lift objects, could affect the machine lift performance.

Lift capacity stays with ±5% for all available track shoes.

Always refer to the appropriate Operation and Maintenance Manual for specific product information.

Maximum length of VAB.

317 Hydraulic Excavator Specifications

Variable Angle Boom Lift Capacities – Counterweight 3.77 mt (8,311 lb) – without Bucket – Blade Up

2700 mm (8'10") Blade

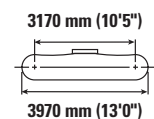
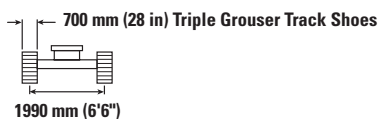
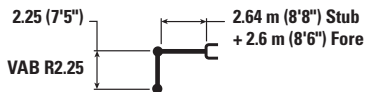

		3000 mm/10'0"		4500 mm/15'0"		6000 mm/20'0"				mm ft/in
7500 mm 25'0"	kg lb	*5950 *13,200	*5950 *13,200	*4000	*4000			*3900 *8,700	*3900 *8,700	4530 14'3"
6000 mm 20'0"	kg lb	*5400 *11,900	*5400 *11,900	*5550 *12,050	*5550 *12,050	*3300	*3300	*3300 *7,250	*3300 *7,250	6010 19'5"
4500 mm 15'0"	kg lb	*7800 *16,200	*7800 *16,200	*6000 *12,950	5800 12,550	*4600 *9,900	3750 8,050	*3100 *6,800	3050 6,700	6860 22'4"
3000 mm 10'0"	kg lb			*7250 *15,500	5450 11,750	*4900 *10,550	3600 7,750	*3100 *6,750	2700 5,950	7300 23'10"
1500 mm 5'0"	kg lb			*8100 *17,600	5100 10,950	5350 11,450	3450 7,450	*3250 *7,100	2600 5,650	7420 24'3"
0 mm 0'0"	kg lb			*7550 *16,400	4900 10,600	5200 11,200	3350 7,200	*3550 *7,800	2650 5,800	7220 23'8"
-1500 mm -5'0"	kg lb	*7100 *15,600	*7100 *15,600	*6150 *13,250	4900 10,550	*4450 *9,500	3350 7,200	*3400 *7,450	2950 6,450	6680 21'10"

Variable Angle Boom Lift Capacities – Counterweight 3.77 mt (8,311 lb) – without Bucket – Blade Up

2700 mm (8'10") Blade

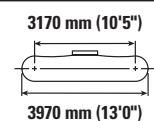
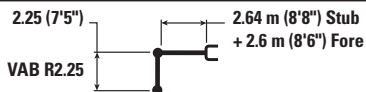

		3000 mm/10'0"		4500 mm/15'0"		6000 mm/20'0"				mm ft/in
7500 mm 25'0"	kg lb	*5950 *13,200	*5950 *13,200	*4000	*4000			*3900 *8,700	*3900 *8,700	4530 14'3"
6000 mm 20'0"	kg lb	*5400 *11,900	*5400 *11,900	*5550 *12,050	*5550 *12,050	*3300	*3300	*3300 *7,250	*3300 *7,250	6010 19'5"
4500 mm 15'0"	kg lb	*7800 *16,200	*7800 *16,200	*6000 *12,950	5900 12,750	*4600 *9,900	3800 8,200	*3100 *6,800	3100 *6,800	6860 22'4"
3000 mm 10'0"	kg lb			*7250 *15,500	5550 11,950	*4900 *10,550	3700 7,900	*3100 *6,750	2750 6,050	7300 23'10"
1500 mm 5'0"	kg lb			*8100 *17,600	5200 11,150	*5400 *11,550	3500 7,600	*3250 *7,100	2650 5,750	7420 24'3"
0 mm 0'0"	kg lb			*7550 *16,400	5000 10,800	5300 11,450	3400 7,350	*3550 *7,800	2700 5,900	7220 23'8"
-1500 mm -5'0"	kg lb	*7100 *15,600	*7100 *15,600	*6150 *13,250	5000 10,750	*4450 *9,500	3400 7,350	*3400 *7,450	3000 6,600	6680 21'10"



ISO 10567:2007



* Indicates that the load is limited by hydraulic lifting capacity rather than tipping load. The above loads are in compliance with hydraulic excavator lift capacity standard ISO 10567:2007. They do not exceed 87% of hydraulic lifting capacity or 75% of tipping load. Weight of all lifting accessories must be deducted from the above lifting capacities. Lifting capacities are based on the machine standing on a firm, uniform supporting surface. The use of a work tool attachment point to handle/lift objects, could affect the machine lift performance.

Lift capacity stays with ±5% for all available track shoes.

Always refer to the appropriate Operation and Maintenance Manual for specific product information.

Maximum length of VAB.

317 Hydraulic Excavator Specifications

Variable Angle Boom Lift Capacities – Counterweight 3.77 mt (8,311 lb) – without Bucket – Blade Up

2500 mm (8'2") Blade

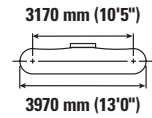
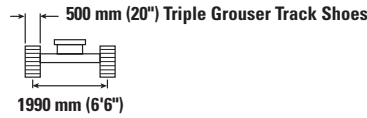
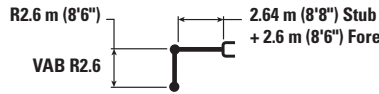

Boom Length	Unit	1500 mm/5'0"		3000 mm/10'0"		4500 mm/15'0"		6000 mm/20'0"		7500 mm/25'0"		Blade Up		mm ft/in
		kg	lb	kg	lb	kg	lb	kg	lb	kg	lb	kg	lb	
9000 mm 30'0"	kg lb	*13,600	*13,600									*5100 *12,900	*5100 *12,900	2250 5'5"
7500 mm 25'0"	kg lb			*5050 *11,250	*5050 *11,250	*4500 *9,300	*4500 *9,300					*3200 *7,100	*3200 *7,100	5050 16'1"
6000 mm 20'0"	kg lb			*4500 *9,950	*4500 *9,950	*4950 *10,850	*4950 *10,850	*4100 *8,250	3750 8,050			*2750 *6,050	*2750 *6,050	6410 20'9"
4500 mm 15'0"	kg lb			*5600 *11,950	*5600 *11,950	*5700 *12,300	*5700 *12,300	*4400 *9,500	3700 7,950			*2600 *5,750	*2600 *5,750	7210 23'6"
3000 mm 10'0"	kg lb					*6850 *14,600	5400 11,600	*4750 *10,150	3550 7,650	*3450 *5,750	2550 5,400	*2600 *5,700	2450 5,400	7640 25'0"
1500 mm 5'0"	kg lb					8050 17,350	5000 10,800	*5200 *11,150	3400 7,300	3750 *8,000	2450 5,300	*2750 *5,950	2350 5,150	7750 25'4"
0 mm 0'0"	kg lb					*7750 16,750	4800 10,300	5100 10,900	3250 7,000	*3500	2450	*3000 *6,550	2400 5,300	7560 24'9"
-1500 mm -5'0"	kg lb			*8200 *17,850	*8200 *17,850	*6550 *14,100	4750 10,200	*4800 *10,250	3200 6,950			*3400 *7,400	2650 5,800	7050 23'0"

Variable Angle Boom Lift Capacities – Counterweight 3.77 mt (8,311 lb) – without Bucket – Blade Up

2600 mm (8'6") Blade

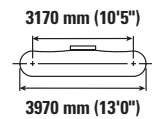
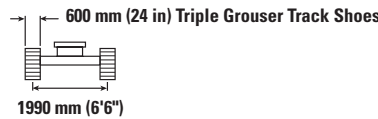
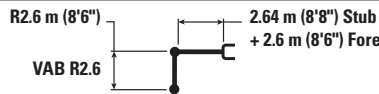

Boom Length	Unit	1500 mm/5'0"		3000 mm/10'0"		4500 mm/15'0"		6000 mm/20'0"		7500 mm/25'0"		Blade Up		mm ft/in
		kg	lb	kg	lb	kg	lb	kg	lb	kg	lb	kg	lb	
9000 mm 30'0"	kg lb	*13,600	*13,600									*5100 *12,900	*5100 *12,900	2250 5'5"
7500 mm 25'0"	kg lb			*5050 *11,250	*5050 *11,250	*4500 *9,300	*4500 *9,300					*3200 *7,100	*3200 *7,100	5050 16'1"
6000 mm 20'0"	kg lb			*4500 *9,950	*4500 *9,950	*4950 *10,850	*4950 *10,850	*4100 *8,250	3800 8,150			*2750 *6,050	*2750 *6,050	6410 20'9"
4500 mm 15'0"	kg lb			*5600 *11,950	*5600 *11,950	*5700 *12,300	*5700 *12,300	*4400 *9,500	3750 8,050			*2600 *5,750	*2600 *5,750	7210 23'6"
3000 mm 10'0"	kg lb					*6850 *14,600	5450 11,750	*4750 *10,150	3600 7,750	*3450 *5,750	2550 5,450	*2600 *5,700	2500 5,450	7640 25'0"
1500 mm 5'0"	kg lb					*8100 *17,450	5050 10,900	*5200 *11,150	3400 7,350	3800 *8,000	2500 5,350	*2750 *5,950	2400 5,250	7750 25'4"
0 mm 0'0"	kg lb					*7750 *16,800	4850 10,450	5150 11,050	3300 7,100	*3500	2450	*3000 *6,550	2450 5,350	7560 24'9"
-1500 mm -5'0"	kg lb			*8200 *17,850	*8200 *17,850	*6550 *14,100	4800 10,300	*4800 *10,250	3250 7,000			*3400 *7,400	2700 5,900	7050 23'0"



ISO 10567:2007



* Indicates that the load is limited by hydraulic lifting capacity rather than tipping load. The above loads are in compliance with hydraulic excavator lift capacity standard ISO 10567:2007. They do not exceed 87% of hydraulic lifting capacity or 75% of tipping load. Weight of all lifting accessories must be deducted from the above lifting capacities. Lifting capacities are based on the machine standing on a firm, uniform supporting surface. The use of a work tool attachment point to handle/lift objects, could affect the machine lift performance.

Lift capacity stays with ±5% for all available track shoes.

Always refer to the appropriate Operation and Maintenance Manual for specific product information.

Maximum length of VAB.

317 Hydraulic Excavator Specifications

Variable Angle Boom Lift Capacities – Counterweight 3.77 mt (8,311 lb) – without Bucket – Blade Up

2700 mm (8'10") Blade

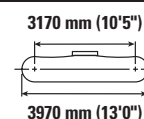

Boom Length	Unit	1500 mm/5'0"		3000 mm/10'0"		4500 mm/15'0"		6000 mm/20'0"		7500 mm/25'0"		mm ft/in		
		kg lb	kg lb	kg lb	kg lb	kg lb	kg lb	kg lb	kg lb	kg lb	kg lb	kg lb	kg lb	
9000 mm 30'0"	kg lb	*13,600	*13,600									*5100 *12,900	*5100 *12,900	2250 5'5"
7500 mm 25'0"	kg lb			*5050 *11,250	*5050 *11,250	*4500 *9,300	*4500 *9,300					*3200 *7,100	*3200 *7,100	5050 16'1"
6000 mm 20'0"	kg lb			*4500 *9,950	*4500 *9,950	*4950 *10,850	*4950 *10,850	*4100 *8,250	3850 *8,250			*2750 *6,050	*2750 *6,050	6410 20'9"
4500 mm 15'0"	kg lb			*5600 *11,950	*5600 *11,950	*5700 *12,300	*5700 *12,300	*4400 *9,500	3800 8,150			*2600 *5,750	*2600 *5,750	7210 23'6"
3000 mm 10'0"	kg lb					*6850 *14,600	5500 11,850	*4750 *10,150	3650 7,800	*3450 *5,750	2600 5,550	*2600 *5,700	2500 5,550	7640 25'0"
1500 mm 5'0"	kg lb					*8100 *17,450	5150 11,050	*5200 *11,150	3450 7,450	*3850 *8,000	2550 5,450	*2750 *5,950	2400 5,300	7750 25'4"
0 mm 0'0"	kg lb					*7750 *16,800	4900 10,550	5200 11,150	3350 7,200	*3500	2500	*3000 *6,550	2450 5,400	7560 24'9"
-1500 mm -5'0"	kg lb			*8200 *17,850	*8200 *17,850	*6550 *14,100	4850 10,450	*4800 *10,250	3300 7,100			*3400 *7,400	2700 5,950	7050 23'0"

Variable Angle Boom Lift Capacities – Counterweight 3.77 mt (8,311 lb) – without Bucket – Blade Up

2700 mm (8'10") Blade

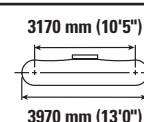
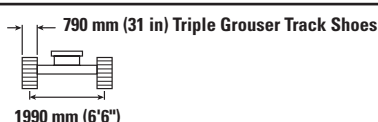
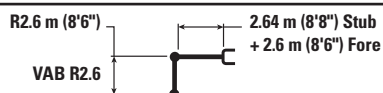

Boom Length	Unit	1500 mm/5'0"		3000 mm/10'0"		4500 mm/15'0"		6000 mm/20'0"		7500 mm/25'0"		mm ft/in		
		kg lb	kg lb	kg lb	kg lb	kg lb	kg lb	kg lb	kg lb	kg lb	kg lb	kg lb	kg lb	
9000 mm 30'0"	kg lb	*13,600	*13,600									*5100 *12,900	*5100 *12,900	2250 5'5"
7500 mm 25'0"	kg lb			*5050 *11,250	*5050 *11,250	*4500 *9,300	*4500 *9,300					*3200 *7,100	*3200 *7,100	5050 16'1"
6000 mm 20'0"	kg lb			*4500 *9,950	*4500 *9,950	*4950 *10,850	*4950 *10,850	*4100 *8,250	3900 *8,250			*2750 *6,050	*2750 *6,050	6410 20'9"
4500 mm 15'0"	kg lb			*5600 *11,950	*5600 *11,950	*5700 *12,300	*5700 *12,300	*4400 *9,500	3850 8,300			*2600 *5,750	*2600 *5,750	7210 23'6"
3000 mm 10'0"	kg lb					*6850 *14,600	5600 12,050	*4750 *10,150	3700 7,950	*3450 *5,750	2650 5,650	*2600 *5,700	2550 5,650	7640 25'0"
1500 mm 5'0"	kg lb					*8100 *17,450	5200 11,250	*5200 *11,150	3550 7,600	*3850 *8,000	2600 5,550	*2750 *5,950	2450 5,400	7750 25'4"
0 mm 0'0"	kg lb					*7750 *16,800	5000 10,750	5300 11,400	3400 7,350	*3500	2550	*3000 *6,550	2500 5,500	7560 24'9"
-1500 mm -5'0"	kg lb			*8200 *17,850	*8200 *17,850	*6550 *14,100	4950 10,650	*4800 *10,250	3350 7,250			*3400 *7,400	2750 6,100	7050 23'0"



ISO 10567:2007



* Indicates that the load is limited by hydraulic lifting capacity rather than tipping load. The above loads are in compliance with hydraulic excavator lift capacity standard ISO 10567:2007. They do not exceed 87% of hydraulic lifting capacity or 75% of tipping load. Weight of all lifting accessories must be deducted from the above lifting capacities. Lifting capacities are based on the machine standing on a firm, uniform supporting surface. The use of a work tool attachment point to handle/lift objects, could affect the machine lift performance.

Lift capacity stays with ±5% for all available track shoes.

Always refer to the appropriate Operation and Maintenance Manual for specific product information.

Maximum length of VAB.

317 Hydraulic Excavator Specifications

Bucket Specifications and Compatibility – Europe

	Linkage	Width		Capacity		Weight		Fill	Reach Boom		Variable Angle Boom	
		mm	in	m ³	yd ³	kg	lb		%	R2.6 (8'6")	R3.1 (10'2")	R2.25 (7'5")
Pin-On (No Quick Coupler)												
General Duty	316	600	24	0.35	0.46	440	969	100	●	●	●	●
	316	900	36	0.62	0.81	546	1,203	100	●	●	●	●
	316	1200	48	0.91	1.19	658	1,450	100	●	⊙	⊙	⊙
	316	1300	51	1.00	1.31	695	1,532	100	⊙	⊖	⊙	⊖
Ditch Cleaning	316	2000	78	0.94	1.23	723	1,594	100	⊙	⊖	⊙	⊖
Ditch Cleaning – Tilt	316	2000	79	0.86	1.12	1028	2,266	100	⊙	⊖	⊖	⊖
Maximum load with pin-on (payload + bucket)								kg	2510	2290	2450	2260
								lb	5,523	5,053	5,394	4,975
With Cat Pin Grabber Coupler												
General Duty	316	600	24	0.35	0.46	440	969	100	●	●	●	●
	316	900	36	0.62	0.81	546	1,203	100	●	●	●	●
	316	1200	48	0.91	1.19	658	1,450	100	⊙	⊖	⊙	⊖
	316	1300	51	1.00	1.31	695	1,532	100	⊖	○	⊖	○
Ditch Cleaning	316	2000	78	0.94	1.23	723	1,594	100	⊖	⊖	⊖	○
Ditch Cleaning – Tilt	316	2000	79	0.86	1.12	1028	2,266	100	⊖	○	○	○
Maximum load with coupler (payload + bucket)								kg	2305	2092	2247	2057
								lb	5,082	4,613	4,954	4,534

The above loads are in compliance with hydraulic excavator standard EN474-5:2006+A3:2013, they do not exceed 87% of hydraulic lifting capacity or 75% of tipping capacity with front linkage fully extended at ground line with bucket curled.
Capacity based on ISO 7451:2007.

Maximum Material Density:

- 2100 kg/m³ (3,500 lb/yd³)
- ⊙ 1800 kg/m³ (3,000 lb/yd³)
- ⊖ 1500 kg/m³ (2,500 lb/yd³)
- 1200 kg/m³ (2,000 lb/yd³)

Caterpillar recommends using appropriate work tools to maximize the value customers receive from our products. Use of work tools, including buckets, which are outside of Caterpillar's recommendations or specifications for weight, dimensions, flows, pressures, etc. may result in less-than-optimal performance, including but not limited to reductions in production, stability, reliability, and component durability. Improper use of a work tool resulting in sweeping, prying, twisting and/or catching of heavy loads will reduce the life of the boom and stick.

(continued on next page)

317 Hydraulic Excavator Specifications

Bucket Specifications and Compatibility – Europe (continued)

	Linkage	Width		Capacity		Weight		Fill	Reach Boom		Variable Angle Boom	
		mm	in	m ³	yd ³	kg	lb		%	R2.6 (8'6")	R3.1 (10'2")	R2.25 (7'5")
With CW30 Coupler												
General Duty	316	600	24	0.35	0.46	439	967	100	●	●	●	●
	316	750	30	0.49	0.64	475	1,047	100	●	●	●	●
	316	900	36	0.62	0.81	534	1,177	100	●	●	●	●
	316	1100	43	0.80	1.04	593	1,307	100	●	⊙	●	⊙
	316	1200	48	0.90	1.18	646	1,423	100	⊙	⊖	⊙	⊖
	316	1300	51	1.00	1.31	677	1,492	100	⊖	○	⊖	○
Heavy Duty	316	1300	51	1.00	1.31	694	1,529	100	⊖	○	⊖	○
General Duty – Leveling Edge	316	996	39.2	0.70	0.93	586	1,291	100	●	●	●	●
	316	1200	47	0.91	1.19	672	1,481	100	⊙	⊖	⊙	⊖
	316	690	27	0.47	0.61	476	1,049	100	●	●	●	●
	316	790	31	0.56	0.73	509	1,122	100	●	●	●	●
Ditch Cleaning	316	1400	55	1.09	1.43	738	1,626	100	○	○	○	○
	316	1800	72	1.10	1.44	646	1,423	100	⊖	○	⊖	○
	316	1800	72	1.24	1.62	678	1,496	100	○	◇	○	◇
Ditch Cleaning – Tilt	316	2100	82	1.45	1.90	760	1,675	100	◇	◇	◇	◇
	316	1800	72	0.78	1.02	1048	2,310	100	⊖	○	⊖	○
	316	2000	79	0.86	1.13	1111	2,449	100	○	◇	○	◇
	Maximum load with coupler (payload + bucket)								kg	2287	2074	2229
								lb	5,042	4,572	4,913	4,494
With CW30S Coupler												
General Duty	316	600	24	0.35	0.46	423	932	100	●	●	●	●
	316	750	30	0.49	0.64	471	1,038	100	●	●	●	●
	316	900	36	0.62	0.81	534	1,177	100	●	●	●	●
	316	1100	43	0.80	1.04	593	1,307	100	●	⊙	●	⊙
	316	1200	48	0.91	1.18	646	1,423	100	⊙	⊖	⊙	⊖
	316	1300	51	1.00	1.31	677	1,492	100	⊖	⊖	⊖	○
	316	1400	55	1.09	1.43	707	1,558	100	⊖	○	⊖	○
Heavy Duty	316	1200	48	0.91	1.18	663	1,461	100	⊙	⊖	⊙	⊖
	316	1300	51	1.00	1.31	695	1,531	100	⊖	○	⊖	○
Ditch Cleaning – Tilt	316	2000	79	0.86	1.13	1092	2,407	100	⊖	○	○	○
Maximum load with coupler (payload + bucket)								kg	2322	2109	2264	2073
								lb	5,119	4,650	4,991	4,571

The above loads are in compliance with hydraulic excavator standard EN474-5:2006+A3:2013, they do not exceed 87% of hydraulic lifting capacity or 75% of tipping capacity with front linkage fully extended at ground line with bucket curled.

Capacity based on ISO 7451:2007.

Maximum Material Density:

- 2100 kg/m³ (3,500 lb/yd³)
- ⊙ 1800 kg/m³ (3,000 lb/yd³)
- ⊖ 1500 kg/m³ (2,500 lb/yd³)
- 1200 kg/m³ (2,000 lb/yd³)
- ◇ 900 kg/m³ (1,500 lb/yd³)

Caterpillar recommends using appropriate work tools to maximize the value customers receive from our products. Use of work tools, including buckets, which are outside of Caterpillar's recommendations or specifications for weight, dimensions, flows, pressures, etc. may result in less-than-optimal performance, including but not limited to reductions in production, stability, reliability, and component durability. Improper use of a work tool resulting in sweeping, prying, twisting and/or catching of heavy loads will reduce the life of the boom and stick.

(continued on next page)

317 Hydraulic Excavator Specifications

Bucket Specifications and Compatibility – Europe (continued)

	Linkage	Width		Capacity		Weight		Fill	Reach Boom		Variable Angle Boom	
		mm	in	m ³	yd ³	kg	lb		%	R2.6 (8'6")	R3.1 (10'2")	R2.25 (7'5")
Pin-On, TRS14 CW30												
Grading – General Duty	316	1700	67	0.65	0.85	634	1,397	100	⊙	⊖	⊖	○
Trenching – General Duty	316	660	26	0.45	0.59	395	871	100	●	●	●	●
Maximum load with pin-on (payload + bucket)								kg	1783	1570	1725	1534
								lb	3,931	3,461	3,802	3,383
Pin-On, TRS14 CW30S												
Grading – General Duty	316	1600	63	0.75	0.98	595	1,311	100	⊖	○	⊖	○
Maximum load with pin-on (payload + bucket)								kg	1829	1616	1771	1580
								lb	4,032	3,563	3,904	3,484
Pin-On, TRS14 S60												
Grading – General Duty	316	1600	63	0.75	0.98	576	1,270	100	⊙	⊖	⊙	⊖
	316	1700	67	0.80	1.05	610	1,346	100	⊖	○	⊖	○
	316	1800	71	0.90	1.18	643	1,418	100	⊖	○	○	○
Trenching – General Duty	316	1800	71	0.33	0.43	540	1,190	100	●	●	●	●
Maximum load with pin-on (payload + bucket)								kg	1930	1717	1872	1681
								lb	4,255	3,785	4,126	3,707
CW30, TRS14 CW30												
Grading – General Duty	316	1700	67	0.65	0.85	634	1,397	100	○	◇	○	◇
	316	660	26	0.45	0.59	395	871	100	●	●	●	●
Maximum load with coupler (payload + bucket)								kg	1551	1338	1493	1302
								lb	3,420	2,950	3,291	2,871
CW30S, TRS14 CW30S												
Grading – General Duty	316	1600	63	0.75	0.98	595	1,311	100	○	◇	○	◇
Maximum load with coupler (payload + bucket)								kg	1632	1419	1574	1383
								lb	3,598	3,128	3,469	3,050
S60, TRS10 S60												
Grading – General Duty	316	1600	63	0.75	0.98	576	1,270	100	⊖	○	⊖	○
	316	1700	67	0.80	1.05	610	1,346	100	⊖	○	○	○
	316	1800	71	0.90	1.18	643	1,418	100	○	◇	○	◇
	316	1800	71	0.33	0.43	540	1,190	100	●	●	●	●
Maximum load with coupler (payload + bucket)								kg	1789	1576	1731	1540
								lb	3,944	3,474	3,816	3,396

The above loads are in compliance with hydraulic excavator standard EN474-5:2006+A3:2013, they do not exceed 87% of hydraulic lifting capacity or 75% of tipping capacity with front linkage fully extended at ground line with bucket curled.
Capacity based on ISO 7451:2007.

Maximum Material Density:

- 2100 kg/m³ (3,500 lb/yd³)
- ⊙ 1800 kg/m³ (3,000 lb/yd³)
- ⊖ 1500 kg/m³ (2,500 lb/yd³)
- 1200 kg/m³ (2,000 lb/yd³)
- ◇ 900 kg/m³ (1,500 lb/yd³)

Caterpillar recommends using appropriate work tools to maximize the value customers receive from our products. Use of work tools, including buckets, which are outside of Caterpillar's recommendations or specifications for weight, dimensions, flows, pressures, etc. may result in less-than-optimal performance, including but not limited to reductions in production, stability, reliability, and component durability. Improper use of a work tool resulting in sweeping, prying, twisting and/or catching of heavy loads will reduce the life of the boom and stick.

317 Hydraulic Excavator Specifications

Bucket Specifications and Compatibility – Australia and New Zealand

	Linkage	Width		Capacity		Weight		Fill	Reach Boom	
		mm	in	m ³	yd ³	kg	lb		%	R2.6 (8'6")
Pin-On (No Quick Coupler)										
General Duty	316	600	24	0.35	0.46	440	969	100	●	●
	316	900	36	0.62	0.81	546	1,203	100	●	●
	316	1200	48	0.91	1.19	658	1,450	100	●	⊙
Clean Up	316	1500	60	1.24	1.62	770	1,698	100	○	○
	316	1800	72	1.53	2.00	911	2,008	100	◇	◇
Ditch Cleaning – Tilt	316	1800	72	0.78	1.02	985	2,170	100	⊙	⊖
Maximum load with pin-on (payload + bucket)								kg	2510	2290
								lb	5,523	5,053
With Cat Pin Grabber Coupler										
General Duty	316	600	24	0.35	0.46	440	969	100	●	●
	316	900	36	0.62	0.81	546	1,203	100	●	●
	316	1200	48	0.91	1.19	658	1,450	100	⊙	⊖
Clean Up	316	1500	60	1.24	1.62	770	1,698	100	○	◇
	316	1800	72	1.53	2.00	911	2,008	100	◇	X
Ditch Cleaning – Tilt	316	1800	72	0.78	1.02	985	2,170	100	⊖	○
Maximum load with coupler (payload + bucket)								kg	2305	2092
								lb	5,082	4,613

The above loads are in compliance with hydraulic excavator standard EN474-5:2006+A3:2013, they do not exceed 87% of hydraulic lifting capacity or 75% of tipping capacity with front linkage fully extended at ground line with bucket curled.
Capacity based on ISO 7451:2007.

Maximum Material Density:

- 2100 kg/m³ (3,500 lb/yd³)
- ⊙ 1800 kg/m³ (3,000 lb/yd³)
- ⊖ 1500 kg/m³ (2,500 lb/yd³)
- 1200 kg/m³ (2,000 lb/yd³)
- ◇ 900 kg/m³ (1,500 lb/yd³)

Caterpillar recommends using appropriate work tools to maximize the value customers receive from our products. Use of work tools, including buckets, which are outside of Caterpillar's recommendations or specifications for weight, dimensions, flows, pressures, etc. may result in less-than-optimal performance, including but not limited to reductions in production, stability, reliability, and component durability. Improper use of a work tool resulting in sweeping, prying, twisting and/or catching of heavy loads will reduce the life of the boom and stick.

317 Hydraulic Excavator Specifications

Attachments Offering Guide – Europe

Not all Attachments are available in all regions. Consult your Cat dealer for configurations available in your region.

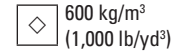
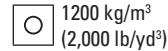

PIN-ON ATTACHMENTS

Boom Type	Stick Length	Reach		VA	
		2.60 m (8'6")	3.10 m (10'2")	2.25 m (7'5")	2.60 m (8'6")
Hydraulic Hammers	H110 S	✓	✓	✓	✓
	H115 GC S	✓	✓	✓	✓
	H115 S	✓	✓	✓	✓
	H120 S	✓	✓	✓	✓
Demolition and Sorting Grapples	G313 GC	✓	✓	✓	✓
	G314	✓	✓	✓	✓
	G317 GC	✓	✓	✓	✓
Mobile Scrap and Demolition Shears	S3015 Flat Top	✓	✓	✓	✓
Pulverizers	P214 Secondary Pulverizer	✓	✓	✓	✓
Compactors (Vibratory Plate)	CVP75	✓	✓	✓	✓
Rotary Cutters	RC15	✓	✓	✓	✓
Orange Peel Grapples	GSH420-500	●	●	●	●
	GSH420-600	●	○	●	○
	GSH420-750	○	○	○	○
	GSH520-500	●	○	●	○
	GSH520-600	○	○	○	○
	GSH520-750	○		○	
	GSV420-400	●	●	●	●
	GSV420-500	●	●	●	●
	GSV420-600	●	●	●	●
	GSV420-750	○	○	○	○
	GSV420-1250	◇	◇	◇	◇
	GSV520 GC-400	●	●	●	●
	GSV520 GC-500	●	●	●	●
	GSV520 GC-600	●	○	●	○
	GSV520 GC-750	○	○	○	○
	GSV520 GC-1250	◇	◇	◇	◇
	GSV520-400	●	●	●	●
	GSV520-500	●	●	●	●
	GSV520-600	●	○	●	○
	GSV520-750	○		○	○
	GSV520-1250	◇	◇	◇	◇

(continued on next page)

317 Hydraulic Excavator Specifications

Attachments Offering Guide – Europe (continued)

Not all Attachments are available in all regions. Consult your Cat dealer for configurations available in your region.

Match

* Working range front only

No Match

CAT PIN GRABBER COUPLER ATTACHMENTS

Boom Type	Stick Length		Reach		VA	
			2.60 m (8'6")	3.10 m (10'2")	2.25 m (7'5")	2.60 m (8'6")
Hydraulic Hammers		H110 S	✓	✓	✓	✓
		H115 GC S	✓	✓	✓	✓
		H115 S	✓	✓	✓	✓
		H120 S	✓	✓	✓	✓
Demolition and Sorting Grapples		G313 GC	✓	✓	✓	✓
		G314	✓	✓	✓	✓
		G317 GC	✓*			
Mobile Scrap and Demolition Shears		S3015 Flat Top	✓	✓	✓	✓
Pulverizers		P214 Secondary Pulverizer	✓	✓*		
Compactors (Vibratory Plate)		CVP75	✓	✓	✓	✓
Rotary Cutters		RC15	✓	✓	✓	✓

CW-30s DEDICATED COUPLER ATTACHMENTS

Boom Type	Stick Length		Reach		VA	
			2.60 m (8'6")	3.10 m (10'2")	2.25 m (7'5")	2.60 m (8'6")
Hydraulic Hammers		H110 S	✓	✓	✓	✓
		H115 GC S	✓	✓	✓	✓
		H115 S	✓	✓	✓	✓
		H120 S	✓	✓		
Demolition and Sorting Grapples		G313 GC	✓	✓	✓	✓
		G314	✓	✓	✓	✓
		G317 GC	✓	✓*		
Mobile Scrap and Demolition Shears		S3015 Flat Top	✓	✓	✓	✓
Pulverizers		P214 Secondary Pulverizer	✓	✓		
Compactors (Vibratory Plate)		CVP75	✓	✓	✓	✓
Rotary Cutters		RC15	✓	✓	✓	✓

CW-30 DEDICATED COUPLER ATTACHMENTS

Boom Type	Stick Length		Reach		VA	
			2.60 m (8'6")	3.10 m (10'2")	2.25 m (7'5")	2.60 m (8'6")
Hydraulic Hammers		H110 S	✓	✓	✓	✓
		H115 GC S	✓	✓	✓	✓
		H115 S	✓	✓	✓	✓
		H120 S	✓	✓		
Demolition and Sorting Grapples		G313 GC	✓	✓	✓	✓
		G313 GC fixed CAN	✓	✓	✓	✓
		G314	✓	✓	✓	✓
		G317 GC	✓	✓*	✓	✓*
		G317 GC fixed CAN	✓	✓		
Mobile Scrap and Demolition Shears		S3015 Flat Top	✓	✓	✓	✓
Pulverizers		P214 Secondary Pulverizer	✓	✓	✓	✓
Compactors (Vibratory Plate)		CVP75	✓	✓	✓	✓
Rotary Cutters		RC15	✓	✓	✓	✓

(continued on next page)

317 Hydraulic Excavator Specifications

Attachments Offering Guide – Europe (continued)

Not all Attachments are available in all regions. Consult your Cat dealer for configurations available in your region.

Match

* Working range front only

No Match

HCCW30 DEDICATED COUPLER ATTACHMENTS

Boom Type	Stick Length		Reach		VA	
			2.60 m (8'6")	3.10 m (10'2")	2.25 m (7'5")	2.60 m (8'6")
Hydraulic Hammers		H110 S	✓	✓	✓	✓
		H115 GC S	✓	✓	✓	✓
		H115 S	✓	✓	✓	✓
		H120 S	✓			
Demolition and Sorting Grapples		G313 GC	✓	✓	✓	✓
		G314	✓	✓*		
Mobile Scrap and Demolition Shears		S3015 Flat Top	✓	✓		
Pulverizers		P214 Secondary Pulverizer	✓			
Compactors (Vibratory Plate)		CVP75	✓	✓	✓	✓
Rotary Cutters		RC15	✓	✓	✓	✓

S60 DEDICATED COUPLER ATTACHMENTS

Boom Type	Stick Length		Reach		VA	
			2.60 m (8'6")	3.10 m (10'2")	2.25 m (7'5")	2.60 m (8'6")
Hydraulic Hammers		H110 S	✓	✓	✓	✓
		H115 GC S	✓	✓	✓	✓
		H115 S	✓	✓	✓	✓
		H120 S	✓	✓		
Demolition and Sorting Grapples		G313 GC	✓	✓	✓	✓
		G314	✓	✓	✓	✓
		G317 GC	✓	✓*		
Mobile Scrap and Demolition Shears		S3015 Flat Top	✓	✓	✓	✓
Pulverizers		P214 Secondary Pulverizer	✓	✓		
Compactors (Vibratory Plate)		CVP75	✓	✓	✓	✓
Rotary Cutters		RC15	✓	✓	✓	✓

HCS60 DEDICATED COUPLER ATTACHMENTS

Boom Type	Stick Length		Reach		VA	
			2.60 m (8'6")	3.10 m (10'2")	2.25 m (7'5")	2.60 m (8'6")
Hydraulic Hammers		H110 S	✓	✓	✓	✓
		H115 S	✓	✓	✓	✓
		H120 S	✓	✓	✓	✓
Demolition and Sorting Grapples		G313 GC	✓	✓	✓	✓
		G314	✓	✓	✓	✓
		G317 GC	✓	✓*		
Mobile Scrap and Demolition Shears		S3015 Flat Top	✓	✓	✓	✓
Pulverizers		P214 Secondary Pulverizer	✓	✓		
Compactors (Vibratory Plate)		CVP75	✓	✓	✓	✓

(continued on next page)

317 Hydraulic Excavator Specifications

Attachments Offering Guide – Europe (continued)

Not all Attachments are available in all regions. Consult your Cat dealer for configurations available in your region.

Match

* Working range front only

No Match

HCS65 DEDICATED COUPLER ATTACHMENTS

Boom Type	Stick Length		Reach		VA	
			2.60 m (8'6")	3.10 m (10'2")	2.25 m (7'5")	2.60 m (8'6")
Hydraulic Hammers	H110 S		✓	✓	✓	✓
	H115 S		✓	✓	✓	✓
	H120 S		✓	✓	✓	✓
Demolition and Sorting Grapples	G313 GC		✓	✓	✓	✓
	G314		✓	✓	✓	✓
	G317 GC		✓*			
Mobile Scrap and Demolition Shears	S3015 Flat Top		✓	✓	✓	✓
Pulverizers	P214 Secondary Pulverizer		✓	✓		
Compactors (Vibratory Plate)	CVP75		✓	✓	✓	✓
Rotary Cutters	RC15		✓	✓	✓	✓

TRS14 (PIN-ON TOP/CW-30s BOTTOM) ATTACHMENTS

Some attachments require more hydraulic flow and are best suited with a machine that has HP2 circuits and a tiltrotator with a high flow swivel. Check the hydraulic capability of your machine and tiltrotator and the requirements of your attachment to ensure a proper match.

Boom Type	Stick Length		Reach		VA	
			2.60 m (8'6")	3.10 m (10'2")	2.25 m (7'5")	2.60 m (8'6")
Hydraulic Hammers	H110 S		✓	✓	✓	✓
	H115 GC S		✓			
	H115 S		✓	✓		
Demolition and Sorting Grapples	G213 GC		✓	✓		
	G213 GC Fixed CAN		✓	✓	✓	✓
	G217 GC Fixed CAN		✓*			
Compactors (Vibratory Plate)	CVP75		✓	✓	✓	✓

NOTE: Use hammers on tiltrotators less than 10% of working hours per year or maximum 200 hours per year. Refer to your Operation and Maintenance Manual for recommended hydraulic flow requirements.

TRS14 (CW-30s TOP/CW-30S BOTTOM) ATTACHMENTS

Some attachments require more hydraulic flow and are best suited with a machine that has HP2 circuits and a tiltrotator with a high flow swivel. Check the hydraulic capability of your machine and tiltrotator and the requirements of your attachment to ensure a proper match.

Boom Type	Stick Length		Reach	
			2.60 m (8'6")	3.10 m (10'2")
Hydraulic Hammers	H110 S		✓	✓
	H115 S		✓	
Demolition and Sorting Grapples	G213 GC		✓	
	G213 GC Fixed CAN		✓	✓*
Compactors (Vibratory Plate)	CVP75		✓	✓

NOTE: Use hammers on tiltrotators less than 10% of working hours per year or maximum 200 hours per year. Refer to your Operation and Maintenance Manual for recommended hydraulic flow requirements.

(continued on next page)

317 Hydraulic Excavator Specifications

Attachments Offering Guide – Europe (continued)

Not all Attachments are available in all regions. Consult your Cat dealer for configurations available in your region.

Match

* Working range front only

No Match

TRS14 (PIN-ON TOP/CW-30 BOTTOM) ATTACHMENTS

Some attachments require more hydraulic flow and are best suited with a machine that has HP2 circuits and a tiltrotator with a high flow swivel. Check the hydraulic capability of your machine and tiltrotator and the requirements of your attachment to ensure a proper match.

Boom Type	Stick Length		Reach		VA	
			2.60 m (8'6")	3.10 m (10'2")	2.25 m (7'5")	2.60 m (8'6")
Hydraulic Hammers		H110 S	✓	✓		
		H115 GC S	✓	✓*		
		H115 S	✓	✓		
Demolition and Sorting Grapples		G213 GC	✓	✓		
		G213 GC fixed CAN	✓	✓	✓	✓
		G217 GC fixed CAN	✓*			
Compactors (Vibratory Plate)		CVP75	✓	✓	✓	✓

NOTE: Use hammers on tiltrotators less than 10% of working hours per year or maximum 200 hours per year. Refer to your Operation and Maintenance Manual for recommended hydraulic flow requirements.

TRS14 (CW-30 TOP/CW-30 BOTTOM) ATTACHMENTS

Some attachments require more hydraulic flow and are best suited with a machine that has HP2 circuits and a tiltrotator with a high flow swivel. Check the hydraulic capability of your machine and tiltrotator and the requirements of your attachment to ensure a proper match.

Boom Type	Stick Length		Reach		VA	
			2.60 m (8'6")	3.10 m (10'2")	2.25 m (7'5")	2.60 m (8'6")
Hydraulic Hammers		H110 S	✓			
		H115 S	✓*			
Demolition and Sorting Grapples		G213 GC	✓*			
		G213 GC Fixed CAN	✓			
Compactors (Vibratory Plate)		CVP75	✓	✓	✓	✓

NOTE: Use hammers on tiltrotators less than 10% of working hours per year or maximum 200 hours per year. Refer to your Operation and Maintenance Manual for recommended hydraulic flow requirements.

TRS14 (PIN-ON TOP/S60 BOTTOM) ATTACHMENTS

Some attachments require more hydraulic flow and are best suited with a machine that has HP2 circuits and a tiltrotator with a high flow swivel. Check the hydraulic capability of your machine and tiltrotator and the requirements of your attachment to ensure a proper match.

Boom Type	Stick Length		Reach		VA	
			2.60 m (8'6")	3.10 m (10'2")	2.25 m (7'5")	2.60 m (8'6")
Hydraulic Hammers		H110 S	✓	✓	✓	✓
		H115 GC S	✓	✓	✓	✓
		H115 S	✓	✓	✓	✓
Demolition and Sorting Grapples		G213 GC	✓	✓	✓	✓
		G217 GC	✓*			
Compactors (Vibratory Plate)		CVP75	✓	✓	✓	✓

NOTE: Use hammers on tiltrotators less than 10% of working hours per year or maximum 200 hours per year. Refer to your Operation and Maintenance Manual for recommended hydraulic flow requirements.

(continued on next page)

317 Hydraulic Excavator Specifications

Attachments Offering Guide – Europe (continued)

Not all Attachments are available in all regions. Consult your Cat dealer for configurations available in your region.

Match

No Match

TRS14 (S60 TOP/S60 BOTTOM) ATTACHMENTS

Some attachments require more hydraulic flow and are best suited with a machine that has HP2 circuits and a tiltrotator with a high flow swivel. Check the hydraulic capability of your machine and tiltrotator and the requirements of your attachment to ensure a proper match.

Boom Type	Stick Length		Reach		VA	
			2.60 m (8'6")	3.10 m (10'2")	2.25 m (7'5")	2.60 m (8'6")
Hydraulic Hammers		H110 S	✓	✓	✓	✓
		H115 GC S	✓	✓		
		H115 S	✓	✓		
Demolition and Sorting Grapples		G213 GC	✓	✓		
Compactors (Vibratory Plate)		CVP75	✓	✓	✓	✓

NOTE: Use hammers on tiltrotators less than 10% of working hours per year or maximum 200 hours per year. Refer to your Operation and Maintenance Manual for recommended hydraulic flow requirements.

TRS14 (PIN-ON TOP/HCS60 BOTTOM) ATTACHMENTS

Some attachments require more hydraulic flow and are best suited with a machine that has HP2 circuits and a tiltrotator with a high flow swivel. Check the hydraulic capability of your machine and tiltrotator and the requirements of your attachment to ensure a proper match.

Boom Type	Stick Length		Reach		VA	
			2.60 m (8'6")	3.10 m (10'2")	2.25 m (7'5")	2.60 m (8'6")
Hydraulic Hammers		H110 S	✓	✓	✓	✓
		H115 S	✓	✓	✓	✓
Compactors (Vibratory Plate)		CVP75	✓	✓	✓	✓

NOTE: Use hammers on tiltrotators less than 10% of working hours per year or maximum 200 hours per year. Refer to your Operation and Maintenance Manual for recommended hydraulic flow requirements.

TRS14 (HCS60 TOP/HCS60 BOTTOM) ATTACHMENTS

Some attachments require more hydraulic flow and are best suited with a machine that has HP2 circuits and a tiltrotator with a high flow swivel. Check the hydraulic capability of your machine and tiltrotator and the requirements of your attachment to ensure a proper match.

Boom Type	Stick Length		Reach		VA	
			2.60 m (8'6")	3.10 m (10'2")	2.25 m (7'5")	2.60 m (8'6")
Hydraulic Hammers		H110 S	✓	✓	✓	✓
		H115 S	✓	✓		
Compactors (Vibratory Plate)		CVP75	✓	✓	✓	✓

NOTE: Use hammers on tiltrotators less than 10% of working hours per year or maximum 200 hours per year. Refer to your Operation and Maintenance Manual for recommended hydraulic flow requirements.

(continued on next page)

317 Hydraulic Excavator Specifications

Attachments Offering Guide – Europe (continued)

Not all Attachments are available in all regions. Consult your Cat dealer for configurations available in your region.

Match * Working range front only No Match

TRS14 (PIN-ON TOP/HCS65 BOTTOM) ATTACHMENTS

Some attachments require more hydraulic flow and are best suited with a machine that has HP2 circuits and a tiltrotator with a high flow swivel. Check the hydraulic capability of your machine and tiltrotator and the requirements of your attachment to ensure a proper match.

Boom Type	Stick Length		Reach		VA	
			2.60 m (8'6")	3.10 m (10'2")	2.25 m (7'5")	2.60 m (8'6")
Hydraulic Hammers	H110 S		✓	✓	✓	✓
	H115 S		✓	✓	✓	✓
Compactors (Vibratory Plate)	CVP75		✓	✓	✓	✓

NOTE: Use hammers on tiltrotators less than 10% of working hours per year or maximum 200 hours per year. Refer to your Operation and Maintenance Manual for recommended hydraulic flow requirements.

TRS14 (HCS65 TOP/HCS65 BOTTOM) ATTACHMENTS

Some attachments require more hydraulic flow and are best suited with a machine that has HP2 circuits and a tiltrotator with a high flow swivel. Check the hydraulic capability of your machine and tiltrotator and the requirements of your attachment to ensure a proper match.

Boom Type	Stick Length		Reach		VA	
			2.60 m (8'6")	3.10 m (10'2")	2.25 m (7'5")	2.60 m (8'6")
Hydraulic Hammers	H110 S		✓	✓*	✓	✓*
	H115 S		✓			
Compactors (Vibratory Plate)	CVP75		✓	✓	✓	✓

NOTE: Use hammers on tiltrotators less than 10% of working hours per year or maximum 200 hours per year. Refer to your Operation and Maintenance Manual for recommended hydraulic flow requirements.

BOOM-MOUNT ATTACHMENTS

Boom Type		Reach	VA
Mobile Scrap and Demolition Shears	S3035 Flat Top	✓	✓

317 Hydraulic Excavator Specifications

Attachments Offering Guide – Australia and New Zealand

Not all Attachments are available in all regions. Consult your Cat dealer for configurations available in your region.

Match

* Working range front only

No Match

PIN-ON ATTACHMENTS

Boom Type		Reach				
Stick Length		2.60 m (8'6")	2.90 m (9'6")	3.10 m (10'2")	2.60 m (8'6")	3.10m (10'2")
Hydraulic Hammers	H110 S	✓	✓	✓	✓	✓
	H115 GC	✓	✓	✓	✓	✓
	H115 GC S	✓	✓	✓	✓	✓
	H115 S	✓	✓	✓	✓	✓
	H120 S	✓	✓	✓	✓	✓
Demolition and Sorting Grapples	G314	✓	✓	✓	✓	✓
Mulchers	HM3013	✓	✓	✓	✓	✓
	HM4015	✓	✓	✓	✓	✓
	HM4815	✓	✓	✓	✓	✓
Compactors (Vibratory Plate)	CVP75	✓	✓	✓	✓	✓
Rotary Cutters	RC15	✓	✓	✓	✓	✓

PIN-ON ATTACHMENTS

Boom Type		Reach				
Stick Length		2.60 m (8'6")	2.90 m (9'6")	3.10 m (10'2")	2.60 m (8'6")	3.10m (10'2")
Hydraulic Hammers	H110 S	✓	✓	✓	✓	✓
	H115 GC	✓	✓	✓	✓	✓
	H115 GC S	✓	✓	✓	✓	✓
	H115 S	✓	✓	✓	✓	✓
	H120 S	✓	✓	✓*	✓	✓
Demolition and Sorting Grapples	G314	✓	✓	✓*	✓	✓
Mulchers	HM3013	✓	✓	✓	✓	✓
	HM4015	✓*			✓	✓*
	HM4815	✓*			✓	✓*
Compactors (Vibratory Plate)	CVP75	✓	✓	✓	✓	✓
Rotary Cutters	RC15	✓	✓	✓	✓	✓

TRS14 (PIN-ON TOP/S60 BOTTOM) ATTACHMENTS

Some attachments require more hydraulic flow and are best suited with a machine that has HP2 circuits and a tiltrotator with a high flow swivel. Check the hydraulic capability of your machine and tiltrotator and the requirements of your attachment to ensure a proper match.

Boom Type		Reach				
Stick Length		2.60 m (8'6")	2.90 m (9'6")	3.10 m (10'2")	2.60 m (8'6")	3.10m (10'2")
Hydraulic Hammers	H110 S	✓	✓	✓	✓	✓
	H115 GC S	✓	✓	✓	✓	✓
	H115 S	✓	✓	✓	✓	✓
Compactors (Vibratory Plate)	CVP75	✓	✓	✓	✓	✓

NOTE: Use hammers on tiltrotators less than 10% of working hours per year or maximum 200 hours per year. Refer to your Operation and Maintenance Manual for recommended hydraulic flow requirements.

317 Standard and Optional Equipment

Standard and Optional Equipment

Standard and optional equipment may vary. Consult your Cat dealer for details.

	Standard	Optional		Standard	Optional
BOOMS, STICKS AND LINKAGES			ELECTRICAL SYSTEM		
Variable Angle Boom (2.64 m [8'8"] Stub + 2.6 m [8'6"] Fore)		✓ ¹	Maintenance free battery	✓	
5.1 m (16'9") Reach boom		✓ ²	Centralized electrical disconnect switch	✓	
2.6 m (8'6") Reach stick		✓	Programmable time-delay LED working lights	✓	
3.1 m (10'2") Reach stick		✓	LED chassis light – 1,800 lumens	✓	
2.25 m (7'5") Reach stick		✓ ¹	LED left-side and right-side VA boom lights – 1,800 lumens	✓	
Bucket linkage, without lifting eye, Cat Grade		✓	LED left-side one-piece boom light – 1,800 lumens	✓	
CAT TECHNOLOGY			LED right-side one-piece boom light – 1,800 lumens		✓
Cat Equipment Management:			LED cab lights – 1,800 lumens		✓
– VisionLink®	✓ ⁴		360° lighting		✓
– VisionLink Productivity		✓ ⁵	ENGINE		
– Remote Flash	✓		Cat® C3.6 single turbo diesel engine	✓	
– Remote Troubleshoot	✓		Three selectable modes: Power, Smart, Eco	✓	
– Work tool recognition and tracking (PL161)	✓		One-touch low idle with automatic engine speed control	✓	
– Operator Coaching		✓ ⁶	Auto engine idle shutdown	✓	
Cat Grade:			–18° C (–0° F) cold start capability	✓ ³	
– Cat Grade with 2D	✓		–25° C (–13° F) cold start capability	✓ ¹	
– Cat Grade with 2D with Attachment Ready Option (ARO)		✓	Two-stage fuel filtration system with water separator and indicator	✓	
– Laser catcher		✓	Sealed double element air filter with integrated pre-cleaner	✓	
– Cat Grade with 3D (single or dual Global Navigation Satellite System [GNSS])		✓	Electric fuel priming pump	✓	
– Compatible with 3D grade systems from Trimble, Topcon, and Leica	✓		Electric cooling fans	✓	
– Cat Grade 3D Ready		✓	*Connect subscription only. Additional subscriptions are available. Contact your Cat dealer for availability.		
– Cat Grade Connectivity		✓ ⁵	¹ Europe only.		
Cat Assist:			² Standard in Australia and New Zealand.		
– Grade Assist	✓		³ Australia and New Zealand only.		
– Boom Assist	✓		⁴ Provides core telematics data to manage health, maintenance insights, and condition monitoring. Other plans available for more comprehensive data reporting. Consult your Cat dealer for details.		
– Bucket Assist	✓		⁵ VisionLink subscription required. Consult your Cat dealer for details.		
– Swing Assist	✓		⁶ VisionLink subscription required for back office reporting. Consult your Cat dealer for details.		
– Lift Assist	✓				
Cat Payload:					
– On-the-go weighing	✓				
– Semiautomatic calibration	✓				
– Payload/cycle information	✓				
– VisionLink Productivity back office reporting		✓ ⁵			
Cat Advanced Payload:					
– Daily totals		✓			
– Custom lists		✓			
– Smart weight target		✓			
– E-ticket Integration		✓ ⁵			
Other:					
Cat Tiltrotator (TRS) integration		✓			

(continued on next page)

Standard and Optional Equipment (continued)

Standard and optional equipment may vary. Consult your Cat dealer for details.

	Standard	Optional		Standard	Optional
HYDRAULIC SYSTEM			SERVICE AND MAINTENANCE		
Electronic main control valve	✓		Side entry to service platform	✓	
Single type electronic main pump	✓		Grouped engine oil and fuel filters	✓	
Boom and stick regeneration circuits	✓		Ground level engine oil dipstick	✓	
Boom and stick drift reduction valve	✓		Scheduled Oil Sampling (S·O·S SM) ports	✓	
Boom lowering check valve	✓		Integrated vehicle health management system	✓	
Stick lowering check valve (for Reach boom)	✓		UNDERCARRIAGE AND STRUCTURES		
Automatic hydraulic oil warm up	✓		500 mm (20") triple grouser track shoes		✓
Automatic two-speed travel	✓		600 mm (24") triple grouser track shoes		✓
Element type main hydraulic filter	✓		700 mm (28") triple grouser track shoes with additional steps		✓
Dedicated hydraulic circuit for AUX pump		✓	790 mm (31") triple grouser track shoes with additional steps		✓ ¹
SAFETY AND SECURITY			Grease lubricated track link	✓	
Rear and right-side-view cameras	✓		Center track guiding guard		✓
360° visibility		✓	Two-piece segmented track guiding guard		✓
Ground level accessible secondary engine shutoff switch in cab	✓		Bottom without swivel guard	✓	
Lockable disconnect switch	✓		Travel motor guards	✓	
Service platform with anti-skid plate and countersunk bolts	✓		3.77 mt (8,311 lb) counterweight	✓	
Signaling/warning horn	✓		Tie-down points	✓	
Swing alarm		✓	2500 mm (8'2") blade		✓
Hydraulic lock out lever	✓		2600 mm (8'6") blade		✓
Inspection lighting		✓	2700 mm (8'10") blade		✓
2D E-Fence:	✓		¹ Europe only.		
– E-ceiling					
– E-floor					
– E-swing					
– E-wall					
– E-cab avoidance					
Auto hammer stop	✓				

Dealer Installed Kits and Attachments

Attachments may vary. Consult your Cat dealer for details.

CAB

- Radial lower wiper (deluxe cab only)
- Left-hand and right-hand electrical pedal (two-way) for tool control
- Dual exit rear window kit
- Rain protector plus cab light cover
- Front windshield laminated glass (P5A glass, EU demolition regulation)
- Key fob (for use with Bluetooth receiver)

SAFETY AND SECURITY

- 76 mm (3") retractable seat belt

GUARDS

- OPG (not compatible with cab light cover, rain protector)
- Mesh guard full front (not compatible with cab light cover, rain protector)
- Mesh guard lower front half
- Full protecting vandalism guard

Cab Options

	Deluxe	Premium* (2 piece windshield)	Premium* (1 piece windshield)
ROPS	●	●	●
Operator Protective Guards (OPG)	○	○	○
High-resolution 254 mm (10") LCD touchscreen monitor	●	●	●
Auto bi-level air conditioner	●	●	●
Jog dial and shortcut keys for monitor control	●	●	●
Keyless push-to-start engine control	●	●	●
Height-adjustable console	●	●	●
Tilt-up left-side console	●	●	●
Heated air-suspension seat	●	X	X
Heated and ventilated air-suspension seat	X	●	●
51 mm (2") seat belt	●	●	●
Monitor integrated Bluetooth radio with USB/Auxiliary ports**	●	X	X
Monitor integrated Bluetooth radio with USB/Auxiliary ports/Digital Audio Broadcasting (DAB)*	●	●	●
12V DC outlets	●	●	●
Document storage	●	●	●
Overhead storage and rear storage with nets	●	●	●
Beverage holder	●	●	●
Cup holder	●	●	●
Openable two-piece front window	●	●	X
One piece front windshield	X	X	●
Rear window emergency exit	●	●	●
Radial wiper with washer	●	X	X
Parallel wiper	X	●	●
Openable polycarbonate skylight hatch	●	●	X
Laminated roof glass	X	X	●
LED dome light	●	●	●
Floor welcome light	●	●	●
Roof sunscreen	●	●	●
Roller front sunscreen	●	●	●
Roller rear sunscreen	○	●	●
Washable floor mat	●	●	●
Beacon ready	●	●	●
Cat Stick Steer	○	○	○
Auxiliary relay	○	○	○

● Standard

○ Optional

X Not available

*Europe only

**Australia and New Zealand only

317 Environmental Declaration

The following information applies to the machine at the time of final manufacture as configured for sale in the regions covered in this document. The content of this declaration is valid as of the date issued; however, content related to machine features and specifications are subject to change without notice. For additional information, please see the machine's Operation and Maintenance Manual.

For more information on sustainability in action and our progress, please visit <https://www.caterpillar.com/en/company/sustainability>.

Engine

- The Cat® C3.6 single turbo diesel engine meets U.S. EPA Tier 4 Final, EU Stage V, and Japan 2014 emission standards.
- Cat diesel engines are required to use ULSD (ultra-low sulfur diesel fuel with 15 ppm of sulfur or less) or ULSD blended with the following lower-carbon intensity fuels** up to:
 - ✓ 20% biodiesel FAME (fatty acid methyl ester)*
 - ✓ 100% renewable diesel, HVO (hydrotreated vegetable oil) and GTL (gas-to-liquid) fuels

Refer to guidelines for successful application. Please consult your Cat dealer or “Caterpillar Machine Fluids Recommendations” (SEBU6250) for details.

**Engines with no aftertreatment devices can use higher blends, up to 100% biodiesel (for use of blends higher than 20% biodiesel, consult your Cat dealer).*

***Tailpipe greenhouse gas emissions from lower-carbon intensity fuels are essentially the same as traditional fuels.*

Air Conditioning System

- The air conditioning system on this machine contains the fluorinated greenhouse gas refrigerant R134a (Global Warming Potential = 1430). The system contains 0.9 kg (2.0 lb) of refrigerant which has a CO₂ equivalent of 1.418 metric tonnes (1.261 tons).

Paint

- Based on best available knowledge, the maximum allowable concentration, measured in parts per million (PPM), of the following heavy metals in paint are:
 - Barium < 0.01%
 - Cadmium < 0.01%
 - Chromium < 0.01%
 - Lead < 0.01%

Sound Performance

ISO 6395:2008 external 101 dB(A)

ISO 6396:2008 internal 72 dB(A)

- Hearing protection may be needed when operating with an open operator station and cab (when not properly maintained or doors/windows open) for extended periods or in a noisy environment.

Oils and Fluids

- Caterpillar factory fills with ethylene glycol coolants. Cat Diesel Engine Antifreeze/Coolant (DEAC) and Cat Extended Life Coolant (ELC) can be recycled. Consult your Cat dealer for more information.
- Cat Bio HYDO™ Advanced is an EU Ecolabel approved biodegradable hydraulic oil.
- Additional fluids are likely to be present, please consult the Operations and Maintenance Manual or the Application and Installation guide for complete fluid recommendations and maintenance intervals.

Features and Technology

- The following features and technology may contribute to fuel savings and/or carbon reduction. Features may vary. Consult your Cat dealer for details.
 - Advanced hydraulic systems balance power and efficiency
 - Smart mode matches machine power to digging requirements automatically
 - Eco mode supports reduced fuel consumption for light applications
 - One-touch low idle with automatic engine speed control
 - Increase operating efficiency with standard Cat technologies that help lower operator fatigue and operating costs
 - The latest hydraulic oil filter provides longer life with a 3,000-hour replacement interval
 - Remote Flash and Remote Troubleshoot

For more complete information on Cat products, dealer services, and industry solutions, visit us on the web at www.cat.com

© 2024 Caterpillar
All rights reserved

Materials and specifications are subject to change without notice. Featured machines in photos may include additional equipment. See your Cat dealer for available options.

CAT, CATERPILLAR, LET'S DO THE WORK, their respective logos, "Caterpillar Corporate Yellow," the "Power Edge" and Cat "Modern Hex" trade dress as well as corporate and product identity used herein, are trademarks of Caterpillar and may not be used without permission. VisionLink is a trademark of Caterpillar Inc., registered in the United States and in other countries.

AEXQ4106-00 (11-2024)
Build Number: 07H
(Europe, Aus-NZ)

