



313 GC

Hydraulic Excavator

Technical Specifications

Configurations and features may vary by region. Please consult your Cat® dealer for availability in your area.

Table of Contents

Specifications	2
Engine	2
Swing Mechanism	2
Weights	2
Track	2
Drive	2
Air Conditioning System	2
Hydraulic System	2
Service Refill Capacities	2
Standards	2
Sound Performance	2
Operating Weights and Ground Pressures	3
Major Component Weights	4
Dimensions	5
Working Ranges and Forces	6
Blade Working Ranges	7
Reach Boom Lift Capacities	8
Reach Boom Lift Capacities – Blade Up	14
Bucket Specifications and Compatibility	20
Attachments Offering Guide:	
Europe	22
Türkiye	25
Standard and Optional Equipment	27
Dealer Installed Kits and Attachments	29
313 GC Environmental Declaration	30

313 GC Hydraulic Excavator Specifications

Engine

Engine Model	Cat® C3.6	
Net Power		
ISO 9249	54.3 kW	73 hp
ISO 9249 (DIN)	74 hp (metric)	
Engine Power		
ISO 14396	55.4 kW	74 hp
ISO 14396 (DIN)	75 hp (metric)	
Bore	98 mm	4 in
Stroke	120 mm	5 in
Displacement	3.6 L	220 in ³
Biodiesel Capability	Up to B20 ⁽¹⁾	

- Meets U.S. EPA Tier 4 Final, EU Stage V, and Japan 2014 emission standards.
- No engine power derating required below 3000 m (9,840 ft) altitude.
- Advertised power is tested per the specified standard in effect at the time of manufacture.
- Net power advertised is the power available at the flywheel when the engine is equipped with fan, air intake system, exhaust system and alternator.
- Engine speed at 2,400 rpm.

⁽¹⁾Cat diesel engines are required to use ULSD (ultra-low sulfur diesel fuel with 15 ppm of sulfur or less) or ULSD blended with the following lower-carbon intensity fuels** up to:

- ✓ 20% biodiesel FAME (fatty acid methyl ester)*
- ✓ 100% renewable diesel, HVO (hydrotreated vegetable oil) and GTL (gas-to-liquid) fuels

Refer to guidelines for successful application. Please consult your Cat dealer or “Caterpillar Machine Fluids Recommendations” (SEBU6250) for details.

**Engines with no aftertreatment devices can use higher blends, up to 100% biodiesel (for use of blends higher than 20% biodiesel, consult your Cat dealer).*

***Tailpipe greenhouse gas emissions from lower-carbon intensity fuels are essentially the same as traditional fuels.*

Swing Mechanism

Swing Speed*	11.5 rpm	
Maximum Swing Torque	35 kN·m	25,888 lbf·ft

*For CE-marked machine default value may be set lower.

Weights

Operating Weight	13 800 kg	30,400 lb
------------------	-----------	-----------

- Long undercarriage, Reach boom, R3.0 (9'10") stick, General Duty (GD) 0.68 m³ (0.89 yd³) bucket, 700 mm (28") triple grouser shoes and 2470 kg (5,445 lb) counterweight.

Track

Optional Track Shoes Width	500 mm	20 in
Optional Track Shoes Width	600 mm	24 in
Optional Track Shoes Width	700 mm	28 in
Optional Track Shoes Width	770 mm	30 in
Number of Shoes (each side)	46	
Number of Track Rollers (each side)	7	
Number of Carrier Rollers (each side)	2	

Drive

Gradeability	35°/70%	
Maximum Travel Speed	5.4 km/h	3.4 mph
Maximum Drawbar Pull	117 kN	26,303 lbf

Air Conditioning System

The air conditioning system on this machine contains the fluorinated greenhouse gas refrigerant R134a (Global Warming Potential = 1430). The system contains 0.85 kg of refrigerant which has a CO₂ equivalent of 1.216 metric tonnes.

Hydraulic System

Main System – Maximum Flow – Implement	247 L/min	65 gal/min
Maximum Pressure – Equipment – Normal	35 000 kPa	5,075 psi
Maximum Pressure – Travel	35 000 kPa	5,075 psi
Maximum Pressure – Swing	26 000 kPa	3,770 psi
Boom Cylinder – Bore	105 mm	4 in
Boom Cylinder – Stroke	1026 mm	40 in
Stick Cylinder – Bore	115 mm	5 in
Stick Cylinder – Stroke	1147 mm	45 in
Bucket Cylinder – Bore	95 mm	4 in
Bucket Cylinder – Stroke	939 mm	37 in

Service Refill Capacities

Fuel Tank Capacity	258 L	68.2 gal
Cooling System	15 L	4.0 gal
Engine Oil	8 L	2.1 gal
Final Drive (each)	3 L	0.8 gal
Hydraulic System (including tank)	85 L	22.5 gal
Hydraulic Tank	70 L	18.5 gal

Standards

Brakes	ISO 10265:2008
Cab/Rollover Protective Structure (ROPS)	ISO 12117-2:2008
Cab	ISO 10262:1998 Level I
Operator Protective Guards (OPG) (optional)	ISO 10262:1998 Level II

Sound Performance

ISO 6395:2008 (external)	99 dB(A)
ISO 6396:2008 (inside cab)	68 dB(A)

- Hearing protection may be needed when operating with an open operator station and cab (when not properly maintained or doors/windows open) for extended periods or in a noisy environment.

313 GC Hydraulic Excavator Specifications

Operating Weights and Ground Pressures

Base Machine Configurations	500 mm (20") Triple Grouser Shoes		500 mm (20") Triple Grouser Shoes with Rubber Pad		500 mm (20") Rubber Track Shoes	
	Weight	Ground Pressure	Weight	Ground Pressure	Weight	Ground Pressure
	kg (lb)	kPa (psi)	kg (lb)	kPa (psi)	kg (lb)	kPa (psi)
Base Frame with Track Rollers and Carrier Roller						
2470 kg (5,445 lb) Counterweight + Long Undercarriage Base Machine						
Reach Boom + R3.0 m (9'10") Stick + 0.68 m ³ (0.89 yd ³) GD Bucket	13 300 (29,300)	39.7 (5.8)	13 900 (30,600)	41.5 (6.0)	13 500 (29,800)	40.3 (5.8)
Reach Boom + R2.5 m (8'2") Stick + 0.68 m ³ (0.89 yd ³) GD Bucket	13 300 (29,300)	39.7 (5.8)	13 800 (30,400)	41.2 (6.0)	13 400 (29,500)	40.0 (5.8)

All operating weights include a 90% fuel tank with 75 kg (165 lb) operator.

Base Machine Configurations	600 mm (24") Triple Grouser Shoes		600 mm (24") Rubber Track Shoes		700 mm (28") Triple Grouser Shoes		770 mm (30") Triple Grouser Shoes	
	Weight	Ground Pressure	Weight	Ground Pressure	Weight	Ground Pressure	Weight	Ground Pressure
	kg (lb)	kPa (psi)	kg (lb)	kPa (psi)	kg (lb)	kPa (psi)	kg (lb)	kPa (psi)
Base Frame with Track Rollers and Carrier Rollers								
2470 kg (5,445 lb) Counterweight and Long Undercarriage Base Machine								
Reach Boom + R3.0 m (9'10") Stick + 0.68 m ³ (0.89 yd ³) GD Bucket	13 600 (30,000)	33.8 (4.9)	13 800 (30,400)	34.3 (5.0)	13 800 (30,400)	29.4 (4.3)	14 000 (30,900)	27.1 (3.9)
Reach Boom + R2.5 m (8'2") Stick + 0.68 m ³ (0.89 yd ³) GD Bucket	13 500 (29,800)	33.5 (4.9)	13 700 (30,200)	34.0 (4.9)	13 800 (30,400)	29.4 (4.3)	13 900 (30,600)	26.9 (3.9)

All operating weights include a 90% fuel tank with 75 kg (165 lb) operator.

313 GC Hydraulic Excavator Specifications

Major Component Weights

	kg	lb
Base Machine Weight: including upper frame, undercarriage, counterweight, without boom, stick, bucket, boom cylinders, stick cylinder, bucket cylinders, tracks, blade, without 90% fuel tank, operator		
With Long Undercarriage	9080	20,020
With Long Undercarriage (Blade Compatible)	9390	20,690
Track Shoes:		
500 mm (20") Triple Grouser Track Shoes	1540	3,390
500 mm (20") Triple Grouser Track Shoes with Rubber Pad	2050	4,520
500 mm (20") Rubber Track Shoes	1670	3,680
600 mm (24") Triple Grouser Track Shoes	1810	4,000
600 mm (24") Rubber Track Shoes	1970	4,340
700 mm (28") Triple Grouser Track Shoes with Additional Steps	2020	4,440
770 mm (30") Triple Grouser Track Shoes with Additional Steps	2160	4770
Two Boom Cylinders	240	530
Weight of 90% Fuel Tank and 75 kg (165 lb) Operator	270	600
Blades (without lines, cylinders, frame modifications):		
2500 mm (8'2") Blade for use with 500 mm (20") Track Shoes	440	960
2600 mm (8'6") Blade for use with 600 mm (24") Track Shoes	490	1,080
2700 mm (8'10") Blade for use with 700 mm (28") Track Shoes and 790 mm (30") Track Shoes	500	1,110
Counterweight:		
2470 kg (5,445 lb) Counterweight	2470	5,440
Swing Frame	1240	2,730
Undercarriages:		
Base Frame with GD Track Rollers and One Carrier Rollers	2620	5,770
Base Frame with GD Track Rollers and One Carrier Rollers (blade compatible)	2900	6,390
Boom (including lines, pins, stick cylinder):		
Reach Boom 4.65 m (15'3")	1030	2,270
Sticks (including lines, pins, bucket cylinder, bucket linkage):		
Reach Stick R2.5 (8'2")	590	1,300
Reach Stick R3.0 (9'10")	650	1,440
Buckets (without linkages, with tips and side cutters):		
0.53 m ³ (0.69 yd ³) GD Bucket	420	940
0.68 m ³ (0.89 yd ³) GD Bucket	500	1,090
0.76 m ³ (0.99 yd ³) GD Bucket	520	1,150
Two Bucket Pins	20	50
Quick Coupler:		
Pin Grabber Quick Coupler	210	470

313 GC Hydraulic Excavator Specifications

Dimensions

All dimensions are approximate and may vary depending on bucket selection.

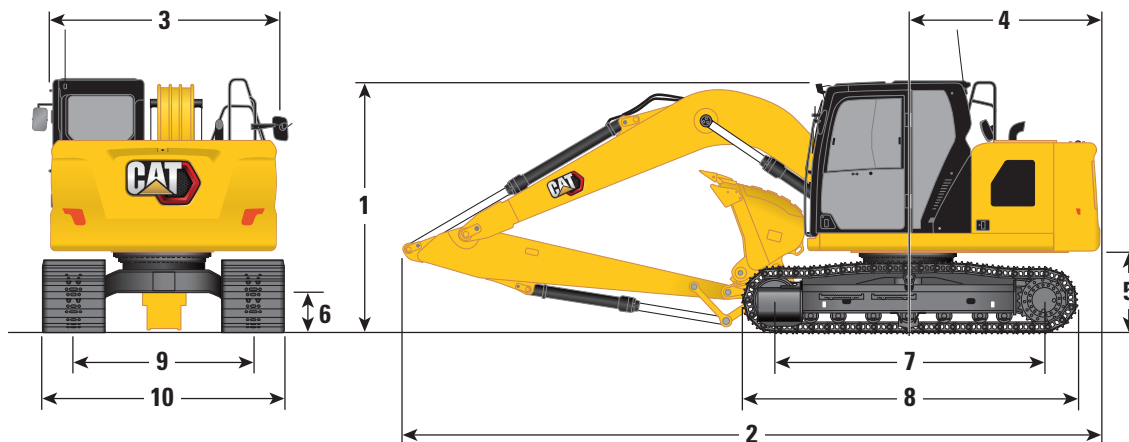

Boom Option

Reach Boom
4.65 m (15'3")

Stick Options

Reach Stick

R2.5 (8'2")

R3.0 (9'10")

1 Machine Height:*

	R2.5 (8'2")		R3.0 (9'10")	
Top of Cab Height	2810 mm	9'3"	2810 mm	9'3"
Top of OPG Height	2960 mm	9'8"	2960 mm	9'8"
Handrails Height	2810 mm	9'3"	2810 mm	9'3"
With Boom/Stick/Bucket Installed (with stick cylinder lines)	2860 mm	9'4"	3200 mm	10'5"
With Boom/Stick Installed (with stick cylinder lines)	2760 mm	9'1"	3190 mm	10'6"
With Boom Installed (with stick cylinder lines)	2340 mm	7'7"	2340 mm	7'7"

2 Machine Length (without blade):

With Boom/Stick/Bucket Installed (with stick cylinder lines)	7700 mm	25'3"	7690 mm	25'2"
With Boom/Stick Installed (with stick cylinder lines)	7690 mm	25'3"	7740 mm	25'4"
With Boom Installed (with stick cylinder lines)	6830 mm	22'4"	6830 mm	22'4"

Machine Length (with blade, blade rear):

With Boom/Stick/Bucket Installed (with stick cylinder lines)	7980 mm	26'2"	7970 mm	26'1"
With Boom/Stick Installed (with stick cylinder lines)	7980 mm	26'2"	8020 mm	26'3"
With Boom Installed (with stick cylinder lines)	7110 mm	23'3"	7110 mm	23'3"

3 Upperframe Width

	2480 mm	8'2"	2480 mm	8'2"
--	---------	------	---------	------

4 Tail Swing Radius – 2470 kg (5,445 lb) counterweight

	2190 mm	7'2"	2190 mm	7'2"
--	---------	------	---------	------

5 Counterweight Clearance

	916 mm	3'0"	916 mm	3'0"
--	--------	------	--------	------

6 Ground Clearance

	446 mm	1'6"	446 mm	1'6"
--	--------	------	--------	------

7 Length to Center of Rollers

	3040 mm	10'0"	3040 mm	10'0"
--	---------	-------	---------	-------

8 Overall Track Length

	3750 mm	12'4"	3750 mm	12'4"
--	---------	-------	---------	-------

9 Track Gauge

	1990 mm	6'6"	1990 mm	6'6"
--	---------	------	---------	------

10 Track Width/Undercarriage Width

500 mm (20") Shoes	2490 mm	8'2"	2490 mm	8'2"
600 mm (24") Shoes	2590 mm	8'6"	2590 mm	8'6"
700 mm (28") Shoes (with steps)	2690 mm	8'10"	2690 mm	8'10"
770 mm (30") Shoes (with steps)	2760 mm	(9'1")	2760 mm	(9'1")

Bucket Type

GD

GD

Bucket Capacity	0.68 m ³	0.89 yd ³	0.68 m ³	0.89 yd ³
Bucket Tip Radius	1240 mm	4'1"	1240 mm	4'1"

*For models with rubber track shoes or rubber pad add 40 mm (1.6") to machine height dimensions.

313 GC Hydraulic Excavator Specifications

Working Ranges and Forces

All dimensions are approximate and may vary depending on bucket selection.

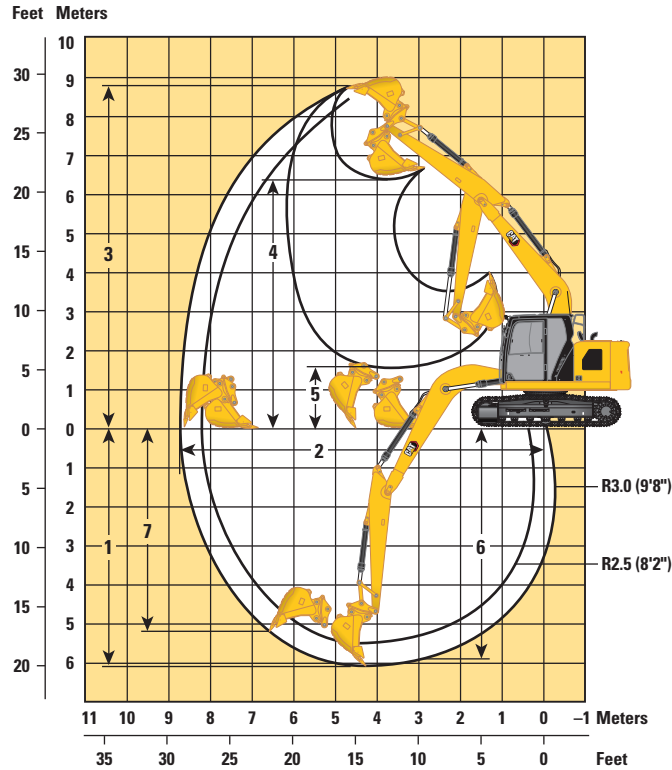

Boom Option

Reach Boom
4.65 m (15'3")

Stick Options

Reach Stick

	R2.5 (8'2")		R3.0 (9'10")	
	GD	GD	GD	GD
1 Maximum Digging Depth	5540 mm	18'2"	6040 mm	19'10"
2 Maximum Reach at Ground Line	8190 mm	26'10"	8660 mm	28'5"
3 Maximum Cutting Height	8560 mm	28'1"	8830 mm	29'0"
4 Maximum Loading Height	6150 mm	20'2"	6420 mm	21'1"
5 Minimum Loading Height	2080 mm	6'10"	1600 mm	5'3"
6 Maximum Depth Cut for 2440 mm (8'0") Level Bottom	5330 mm	17'6"	5860 mm	19'3"
7 Maximum Vertical Wall Digging Depth	4760 mm	15'7"	5190 mm	17'0"
Minimum Working Equipment Radius	2430 mm	8'0"	2570 mm	8'5"
Bucket Digging Force (ISO)	98.45 kN	22,130 lbf	98.67 kN	22,180 lbf
Stick Digging Force (ISO)	66.68 kN	14,990 lbf	59.29 kN	13,330 lbf
Bucket Type	GD		GD	
Bucket Capacity	0.68 m ³	0.89 yd ³	0.68 m ³	0.89 yd ³
Bucket Tip Radius	1240 mm	4'1"	1240 mm	4'1"

313 GC Hydraulic Excavator Specifications

Blade Working Ranges

All dimensions are approximate and may vary depending on bucket selection.

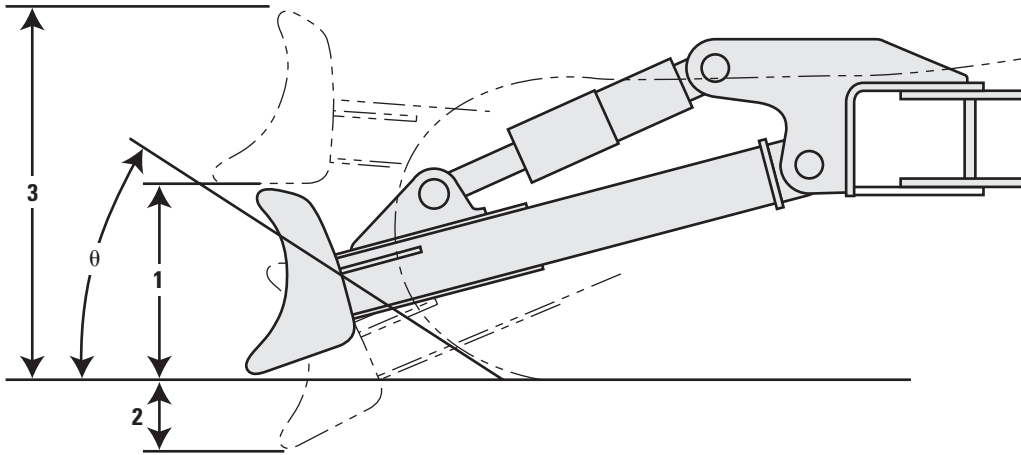

Blade Options	2500 mm (8'2")		2600 mm (8'6")		2700 mm (8'10")	
	1 Blade Height	616 mm	2'0"	616 mm	2'0"	616 mm
2 Maximum Lowering Depth from Ground	550 mm	1'10"	550 mm	1'10"	550 mm	1'10"
3 Maximum Raising Height above Ground	1018 mm	3'4"	1018 mm	3'4"	1018 mm	3'4"
θ Approach Angle	26°		26°		26°	

313 GC Hydraulic Excavator Specifications

Reach Boom Lift Capacities – Counterweight: 2470 kg (5,445 lb) – without Bucket

Long Undercarriage

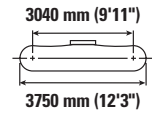
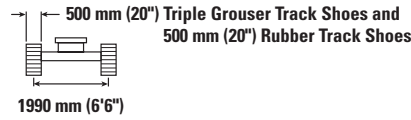
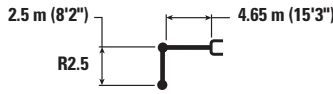

Reach m ft/in	kg lb	1.5 m/5.0 ft		3.0 m/10.0 ft		4.5 m/15.0 ft		6.0 m/20.0 ft		m ft/in		
6.0 m 20'0"	kg lb					*3550 *7,900	*3550 *7,900			*2600 *5,800	*2600 *5,800	5.44 17'6"
4.5 m 15'0"	kg lb					*3800 *8,300	*3800 8,300	*3650 *7,400	2450 5,200	*2450 *5,350	2150 4,800	6.41 20'10"
3.0 m 10'0"	kg lb			*6400 *13,700	*6400 *13,700	*4650 *10,100	3650 7,850	3650 7,800	2350 5,050	*2450 *5,300	1900 4,150	6.93 22'8"
1.5 m 5'0"	kg lb			*7350 *18,000	6100 13,150	5500 11,800	3400 7,350	3550 7,550	2250 4,850	*2550 *5,600	1750 3,850	7.09 23'3"
0.0 m 0'0"	kg lb			*6500 *15,000	5800 12,450	5300 11,300	3250 6,950	3450 7,350	2200 4,650	2800 6,150	1800 3,900	6.93 22'8"
-1.5 m -5'0"	kg lb	*4800 *10,700	*4800 *10,700	*9600 *20,750	5750 12,350	5200 11,150	3150 6,800	3400 7,300	2150 4,600	3100 6,850	2000 4,350	6.41 20'11"
-3.0 m -10'0"	kg lb	*8850 *20,000	*8850 *20,000	*8250 *17,750	5850 12,550	5250 11,250	3200 6,900			4000 8,850	2500 5,550	5.43 17'8"

Reach Boom Lift Capacities – Counterweight: 2470 kg (5,445 lb) – without Bucket

Long Undercarriage

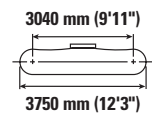
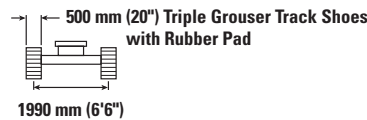
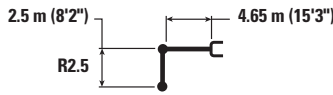

Reach m ft/in	kg lb	1.5 m/5.0 ft		3.0 m/10.0 ft		4.5 m/15.0 ft		6.0 m/20.0 ft		m ft/in		
6.0 m 20'0"	kg lb					*3550 *7,900	*3550 *7,900			*2600 *5,800	*2600 *5,800	5.44 17'6"
4.5 m 15'0"	kg lb					*3800 *8,300	*3800 *8,300	*3650 *7,400	2500 5,400	*2450 *5,350	2250 5,000	6.41 20'10"
3.0 m 10'0"	kg lb			*6400 *13,700	*6400 *13,700	*4650 *10,100	3800 8,150	3750 8,100	2450 5,250	*2450 *5,300	1950 4,300	6.93 22'8"
1.5 m 5'0"	kg lb			*7350 *18,000	6300 13,600	*5700 12,200	3550 7,600	3650 7,850	2350 5,050	*2550 *5,600	1850 4,000	7.09 23'3"
0.0 m 0'0"	kg lb			*6500 *15,000	6000 12,900	5450 11,750	3350 7,200	3550 7,650	2250 4,850	*2850 *6,250	1850 4,050	6.93 22'8"
-1.5 m -5'0"	kg lb	*4800 *10,700	*4800 *10,700	*9600 *20,750	5950 12,800	5400 11,550	3300 7,050	3550 7,600	2250 4,800	3250 7,100	2050 4,500	6.41 20'11"
-3.0 m -10'0"	kg lb	*8850 *20,000	*8850 *20,000	*8250 *17,750	6050 13,000	5450 11,700	3300 7,150			4150 9,200	2600 5,750	5.43 17'8"



ISO 10567:2007



* Indicates that the load is limited by hydraulic lifting capacity rather than tipping load. The above loads are in compliance with hydraulic excavator lift capacity standard ISO 10567:2007. They do not exceed 87% of hydraulic lifting capacity or 75% of tipping load. Weight of all lifting accessories must be deducted from the above lifting capacities. Lifting capacities are based on the machine standing on a firm, uniform supporting surface. The use of a work tool attachment point to handle/lift objects, could affect the machine lift performance.

Lift capacity stays with ±5% for all available track shoes.

Always refer to the appropriate Operation and Maintenance Manual for specific product information.

There may be local regulations and/or government regulations that govern the use of excavators for lifting heavy objects. Obey all local and government regulations.

Regional regulations may require the use of an overload warning device and boom and stick lowering control valves during object handling applications.

Contact your Cat dealer for additional information.

313 GC Hydraulic Excavator Specifications

Reach Boom Lift Capacities – Counterweight: 2470 kg (5,445 lb) – without Bucket

Long Undercarriage

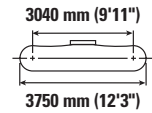
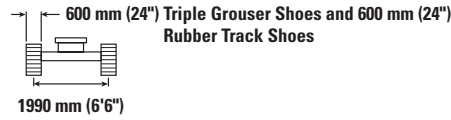
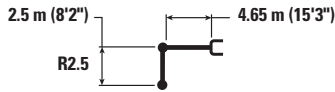

Reach m ft/in	kg lb	1.5 m/5.0 ft		3.0 m/10.0 ft		4.5 m/15.0 ft		6.0 m/20.0 ft		m ft/in		
6.0 m 20'0"	kg lb					*3550 *7,900	*3550 *7,900			*2600 *5,800	*2600 *5,800	5.44 17'6"
4.5 m 15'0"	kg lb					*3800 *8,300	*3800 *8,300	*3650 *7,400	2500 5,300	*2450 *5,350	2200 4,900	6.41 20'10"
3.0 m 10'0"	kg lb			*6400 *13,700	*6400 *13,700	*4650 *10,100	3750 8,000	3700 7,950	2400 5,150	*2450 *5,300	1900 4,200	6.93 22'8"
1.5 m 5'0"	kg lb			*7350 *18,000	6200 13,400	5600 12,000	3450 7,450	3600 7,700	2300 4,950	*2550 *5,600	1800 3,950	7.09 23'3"
0.0 m 0'0"	kg lb			*6500 *15,000	5900 12,700	5400 11,550	3300 7,100	3500 7,500	2200 4,750	*2850 *6,250	1850 4,000	6.93 22'8"
-1.5 m -5'0"	kg lb	*4800 *10,700	*4800 *10,700	*9600 *20,750	5850 12,600	5300 11,400	3200 6,900	3450 7,450	2200 4,700	3150 7,000	2000 4,450	6.41 20'11"
-3.0 m -10'0"	kg lb	*8850 *20,000	*8850 *20,000	*8250 *17,750	5950 12,800	5350 11,500	3250 7,000			4050 9,050	2550 5,650	5.43 17'8"

Reach Boom Lift Capacities – Counterweight: 2470 kg (5,445 lb) – without Bucket

Long Undercarriage

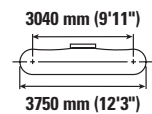
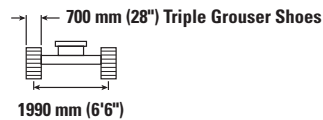
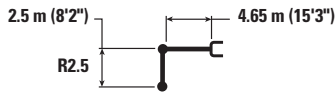

Reach m ft/in	kg lb	1.5 m/5.0 ft		3.0 m/10.0 ft		4.5 m/15.0 ft		6.0 m/20.0 ft		m ft/in		
6.0 m 20'0"	kg lb					*3550 *7,900	*3550 *7,900			*2600 *5,800	*2600 *5,800	5.44 17'6"
4.5 m 15'0"	kg lb					*3800 *8,300	*3800 *8,300	*3650 *7,400	2500 5,400	*2450 *5,350	2250 4,950	6.41 20'10"
3.0 m 10'0"	kg lb			*6400 *13,700	*6400 *13,700	*4650 *10,100	3750 8,100	3750 8,100	2450 5,250	*2450 *5,300	1950 4,250	6.93 22'8"
1.5 m 5'0"	kg lb			*7350 *18,000	6300 13,550	5650 12,150	3500 7,550	3650 7,850	2350 5,000	*2550 *5,600	1850 4,000	7.09 23'3"
0.0 m 0'0"	kg lb			*6500 *15,000	6000 12,850	5450 11,700	3350 7,200	3550 7,650	2250 4,850	*2850 *6,250	1850 4,050	6.93 22'8"
-1.5 m -5'0"	kg lb	*4800 *10,700	*4800 *10,700	*9600 *20,750	5950 12,750	5400 11,550	3250 7,000	3500 7,550	2200 4,750	3200 7,100	2050 4,500	6.41 20'11"
-3.0 m -10'0"	kg lb	*8850 *20,000	*8850 *20,000	*8250 *17,750	6050 13,000	5400 11,650	3300 7,100			4100 9,150	2600 5,750	5.43 17'8"



ISO 10567:2007



* Indicates that the load is limited by hydraulic lifting capacity rather than tipping load. The above loads are in compliance with hydraulic excavator lift capacity standard ISO 10567:2007. They do not exceed 87% of hydraulic lifting capacity or 75% of tipping load. Weight of all lifting accessories must be deducted from the above lifting capacities. Lifting capacities are based on the machine standing on a firm, uniform supporting surface. The use of a work tool attachment point to handle/lift objects, could affect the machine lift performance.

Lift capacity stays with ±5% for all available track shoes.









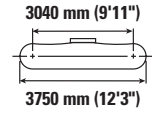
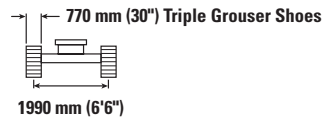
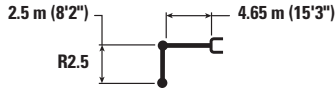

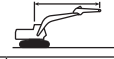
Always refer to the appropriate Operation and Maintenance Manual for specific product information.

313 GC Hydraulic Excavator Specifications

Reach Boom Lift Capacities – Counterweight: 2470 kg (5,445 lb) – without Bucket

Long Undercarriage



Reach	Unit	1.5 m/5.0 ft		3.0 m/10.0 ft		4.5 m/15.0 ft		6.0 m/20.0 ft				m ft/in
												
6.0 m 20'0"	kg lb					*3550 *7,900	*3550 *7,900			*2600 *5,800	*2600 *5,800	5.44 17'6"
4.5 m 15'0"	kg lb					*3800 *8,300	*3800 *8,300	*3650 *7,400	2550 5,450	*2450 *5,350	2250 5,000	6.41 20'10"
3.0 m 10'0"	kg lb			*6400 *13,700	*6400 *13,700	*4650 *10,100	3800 8,200	3800 8,150	2450 5,300	*2450 *5,300	1950 4,300	6.93 22'8"
1.5 m 5'0"	kg lb			*7350 *18,000	6350 13,700	*5700 *12,250	3550 7,650	3700 7,900	2350 5,100	*2550 *5,600	1850 4,050	7.09 23'3"
0.0 m 0'0"	kg lb			*6500 *15,000	6050 13,000	5500 11,850	3400 7,250	3600 7,700	2300 4,900	*2850 *6,250	1850 4,100	6.93 22'8"
-1.5 m -5'0"	kg lb	*4800 *10,700	*4800 *10,700	*9600 *20,750	6000 12,900	5450 11,650	3300 7,100	3550 7,650	2250 4,850	3250 7,150	2050 4,550	6.41 20'11"
-3.0 m -10'0"	kg lb	*8850 *20,000	*8850 *20,000	*8250 *17,750	6100 13,150	5500 11,800	3350 7,200			4150 9,250	2600 5,800	5.43 17'8"



ISO 10567:2007



* Indicates that the load is limited by hydraulic lifting capacity rather than tipping load. The above loads are in compliance with hydraulic excavator lift capacity standard ISO 10567:2007. They do not exceed 87% of hydraulic lifting capacity or 75% of tipping load. Weight of all lifting accessories must be deducted from the above lifting capacities. Lifting capacities are based on the machine standing on a firm, uniform supporting surface. The use of a work tool attachment point to handle/lift objects, could affect the machine lift performance.

Lift capacity stays with ±5% for all available track shoes.

Always refer to the appropriate Operation and Maintenance Manual for specific product information.

313 GC Hydraulic Excavator Specifications

Reach Boom Lift Capacities – Counterweight: 2470 kg (5,445 lb) – without Bucket

Long Undercarriage

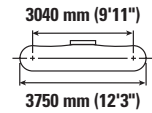
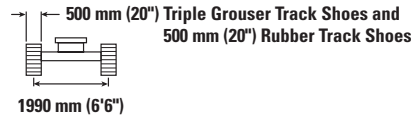
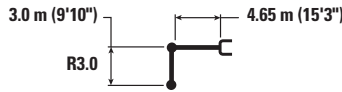

		1.5 m/5.0 ft		3.0 m/10.0 ft		4.5 m/15.0 ft		6.0 m/20.0 ft		7.5 m/25.0 ft		m ft/in		
7.5 m 25'0"	kg lb											*2600 *5,850	*2600 *5,850	4.49 14'1"
6.0 m 20'0"	kg lb							*2250	*2250			*2200 *4,850	*2200 *4,850	6.03 19'6"
4.5 m 15'0"	kg lb							*3350 *7,300	2500 5,300			*2050 *4,500	1950 4,250	6.92 22'6"
3.0 m 10'0"	kg lb			*5350 *11,450	*5350 *11,450	*4200 *9,050	3700 8,000	3650 7,850	2400 5,100			*2050 *4,500	1700 3,700	7.4 24'2"
1.5 m 5'0"	kg lb			*8200 *17,650	6250 13,500	*5300 *11,400	3450 7,400	3550 7,600	2250 4,850	*2400	1600	*2150 *4,750	1600 3,500	7.55 24'9"
0.0 m 0'0"	kg lb			*7250 *16,750	5800 12,450	5300 11,350	3250 6,950	3400 7,350	2150 4,650			*2400 *5,250	1600 3,500	7.4 24'3"
-1.5 m -5'0"	kg lb	*4350 *9,700	*4350 *9,700	*9200 *21,000	5700 12,200	5150 11,050	3100 6,700	3350 7,200	2100 4,500			2750 6,050	1750 3,850	6.91 22'7"
-3.0 m -10'0"	kg lb	*7450 *16,800	*7450 *16,800	*8800 *19,050	5750 12,300	5150 11,100	3100 6,700	3400	2150			3350 7,500	2100 4,700	6.02 19'7"
-4.5 m -15'0"	kg lb			*6400 *13,550	5950 12,800							*4000 *8,800	3300 7,500	4.48 14'4"

Reach Boom Lift Capacities – Counterweight: 2470 kg (5,445 lb) – without Bucket

Long Undercarriage

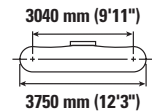
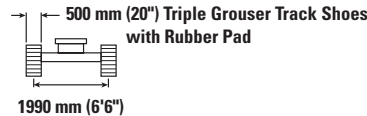
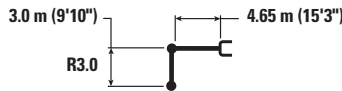

		1.5 m/5.0 ft		3.0 m/10.0 ft		4.5 m/15.0 ft		6.0 m/20.0 ft		7.5 m/25.0 ft		m ft/in		
7.5 m 25'0"	kg lb											*2600 *5,850	*2600 *5,850	4.49 14'1"
6.0 m 20'0"	kg lb							*2250	*2250			*2200 *4,850	*2200 *4,850	6.03 19'6"
4.5 m 15'0"	kg lb							*3350 *7,300	2550 5,450			*2050 *4,500	2000 4,400	6.92 22'6"
3.0 m 10'0"	kg lb			*5350 *11,450	*5350 *11,450	4200 9,050	3850 8,250	*3700 *8,000	2450 5,300			*2050 *4,500	1750 3,850	7.4 24'2"
1.5 m 5'0"	kg lb			*8200 *17,650	6500 13,950	5300 11,400	3550 7,650	3650 7,850	2350 5,050	*2400	1650	*2150 *4,750	1650 3,600	7.55 24'9"
0.0 m 0'0"	kg lb			*7250 *16,750	6000 12,900	5500 11,750	3350 7,200	3550 7,600	2250 4,800			*2400 *5,250	1650 3,650	7.4 24'3"
-1.5 m -5'0"	kg lb	*4350 *9,700	*4350 *9,700	*9200 *21,000	5900 12,650	5350 11,500	3250 6,950	3500 7,500	2200 4,700			*2850 *6,250	1800 4,000	6.91 22'7"
-3.0 m -10'0"	kg lb	*7450 *16,800	*7450 *16,800	*8800 *19,050	5950 12,750	5350 11,500	3250 6,950	3500	2200			3500 7,750	2200 4,900	6.02 19'7"
-4.5 m -15'0"	kg lb			*6400 *13,550	6150 13,250							*4000 *8,800	3450 7,800	4.48 14'4"



ISO 10567:2007



* Indicates that the load is limited by hydraulic lifting capacity rather than tipping load. The above loads are in compliance with hydraulic excavator lift capacity standard ISO 10567:2007. They do not exceed 87% of hydraulic lifting capacity or 75% of tipping load. Weight of all lifting accessories must be deducted from the above lifting capacities. Lifting capacities are based on the machine standing on a firm, uniform supporting surface. The use of a work tool attachment point to handle/lift objects, could affect the machine lift performance.

Lift capacity stays with ±5% for all available track shoes.

Always refer to the appropriate Operation and Maintenance Manual for specific product information.

313 GC Hydraulic Excavator Specifications

Reach Boom Lift Capacities – Counterweight: 2470 kg (5,445 lb) – without Bucket

Long Undercarriage

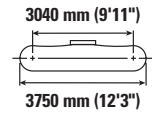
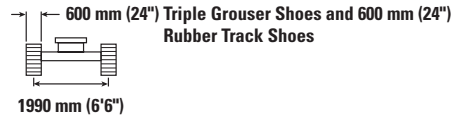
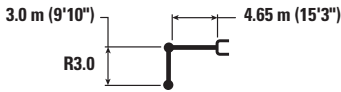

		1.5 m/5.0 ft		3.0 m/10.0 ft		4.5 m/15.0 ft		6.0 m/20.0 ft		7.5 m/25.0 ft		m ft/in		
7.5 m 25'0"	kg lb											*2600 *5,850	*2600 *5,850	4.49 14'1"
6.0 m 20'0"	kg lb							*2250	*2250			*2200 *4,850	*2200 *4,850	6.03 19'6"
4.5 m 15'0"	kg lb							*3350 *7,300	2500 5,400			*2050 *4,500	1950 4,350	6.92 22'6"
3.0 m 10'0"	kg lb			*5350 *11,450	*5350 *11,450	*4200 *9,050	3800 8,150	*3700 *8,000	2450 5,200			*2050 *4,500	1700 3,800	7.4 24'2"
1.5 m 5'0"	kg lb			*8200 *17,650	6400 13,750	*5300 *11,400	3500 7,550	3600 7,750	2300 4,950	*2400	1650	*2150 *4,750	1650 3,550	7.55 24'9"
0.0 m 0'0"	kg lb			*7250 *16,750	5900 12,700	5400 11,550	3300 7,050	3500 7,500	2200 4,750			*2400 *5,250	1650 3,600	7.4 24'3"
-1.5 m -5'0"	kg lb	*4350 *9,700	*4350 *9,700	*9200 *21,000	5800 12,450	5250 11,300	3200 6,850	3450 7,350	2150 4,600			2800 6,200	1800 3,900	6.91 22'7"
-3.0 m -10'0"	kg lb	*7450 *16,800	*7450 *16,800	*8800 *19,050	5850 12,550	5250 11,300	3200 6,850	3450	2200			3450 7,650	2150 4,800	6.02 19'7"
-4.5 m -15'0"	kg lb			*6400 *13,550	6050 13,050							*4000 *8,800	3350 7,650	4.48 14'4"

Reach Boom Lift Capacities – Counterweight: 2470 kg (5,445 lb) – without Bucket

Long Undercarriage

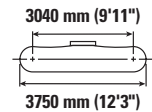
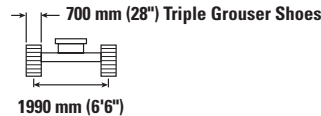
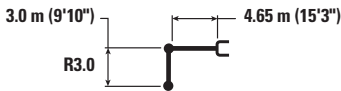

		1.5 m/5.0 ft		3.0 m/10.0 ft		4.5 m/15.0 ft		6.0 m/20.0 ft		7.5 m/25.0 ft		m ft/in		
7.5 m 25'0"	kg lb											*2600 *5,850	*2600 *5,850	4.49 14'1"
6.0 m 20'0"	kg lb							*2250	*2250			*2200 *4,850	*2200 *4,850	6.03 19'6"
4.5 m 15'0"	kg lb							*3350 *7,300	2550 5,450			*2050 *4,500	2000 4,400	6.92 22'6"
3.0 m 10'0"	kg lb			*5350 *11,450	*5350 *11,450	*4200 *9,050	3850 8,250	*3700 *8,000	2450 5,300			*2050 *4,500	1750 3,850	7.4 24'2"
1.5 m 5'0"	kg lb			*8200 *17,650	6450 13,900	*5300 *11,400	3550 7,650	3650 7,850	2350 5,050	*2400	1650	*2150 *4,750	1650 3,600	7.55 24'9"
0.0 m 0'0"	kg lb			*7250 *16,750	6000 12,900	5450 11,750	3350 7,150	3550 7,600	2250 4,800			*2400 *5,250	1650 3,650	7.4 24'3"
-1.5 m -5'0"	kg lb	*4350 *9,700	*4350 *9,700	*9200 *21,000	5900 12,600	5350 11,450	3250 6,950	3500 7,450	2200 4,700			*2850 *6,250	1800 3,950	6.91 22'7"
-3.0 m -10'0"	kg lb	*7450 *16,800	*7450 *16,800	*8800 *19,050	5950 12,750	5350 11,450	3250 6,950	3500	2200			3500 7,750	2200 4,850	6.02 19'7"
-4.5 m -15'0"	kg lb			*6400 *13,550	6150 13,250							*4000 *8,800	3400 7,750	4.48 14'4"



ISO 10567:2007



* Indicates that the load is limited by hydraulic lifting capacity rather than tipping load. The above loads are in compliance with hydraulic excavator lift capacity standard ISO 10567:2007. They do not exceed 87% of hydraulic lifting capacity or 75% of tipping load. Weight of all lifting accessories must be deducted from the above lifting capacities. Lifting capacities are based on the machine standing on a firm, uniform supporting surface. The use of a work tool attachment point to handle/lift objects, could affect the machine lift performance.

Lift capacity stays with ±5% for all available track shoes.

Always refer to the appropriate Operation and Maintenance Manual for specific product information.

313 GC Hydraulic Excavator Specifications

Reach Boom Lift Capacities – Counterweight: 2470 kg (5,445 lb) – without Bucket

Long Undercarriage

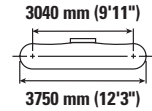
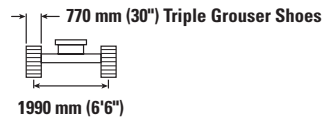
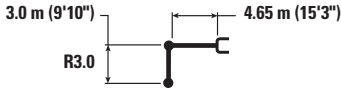

		1.5 m/5.0 ft		3.0 m/10.0 ft		4.5 m/15.0 ft		6.0 m/20.0 ft		7.5 m/25.0 ft		m ft/in		
6.0 m 20'0"	kg lb							*2250	*2250			*2200 *4,850	*2200 *4,850	6.03 19'6"
4.5 m 15'0"	kg lb							*3350 *7,300	2600 5,500			*2050 *4,500	2000 4,450	6.92 22'6"
3.0 m 10'0"	kg lb			*5350 *11,450	*5350 *11,450	*4200 *9,050	3850 8,300	*3700 *8,000	2500 5,350			*2050 *4,500	1750 3,900	7.40 24'2"
1.5 m 5'0"	kg lb			*8200 *17,650	6550 14,050	*5300 *11,400	3600 7,750	3700 7,950	2350 5,100	*2400	1700	*2150 *4,750	1650 3,650	7.55 24'9"
0.0 m 0'0"	kg lb			*7250 *16,750	6050 13,050	5550 11,850	3350 7,250	3600 7,700	2250 4,850			*2400 *5,250	1700 3,700	7.40 24'3"
-1.5 m -5'0"	kg lb	*4350 *9,700	*4350 *9,700	*9200 *21,000	5950 12,750	5400 11,600	3250 7,000	3500 7,550	2200 4,750			*2850 *6,250	1850 4,000	6.91 22'7"
-3.0 m -10'0"	kg lb	*7450 *16,800	*7450 *16,800	*8800 *19,050	6000 12,850	5400 11,600	3250 7,000	3550	2250			3550 7,850	2200 4,900	6.02 19'7"
-4.5 m -15'0"	kg lb			*6400 *13,550	6200 13,350							*4000 *8,800	3450 7,850	4.48 14'4"



ISO 10567:2007



* Indicates that the load is limited by hydraulic lifting capacity rather than tipping load. The above loads are in compliance with hydraulic excavator lift capacity standard ISO 10567:2007. They do not exceed 87% of hydraulic lifting capacity or 75% of tipping load. Weight of all lifting accessories must be deducted from the above lifting capacities. Lifting capacities are based on the machine standing on a firm, uniform supporting surface. The use of a work tool attachment point to handle/lift objects, could affect the machine lift performance.

Lift capacity stays with ±5% for all available track shoes.

Always refer to the appropriate Operation and Maintenance Manual for specific product information.

313 GC Hydraulic Excavator Specifications

Reach Boom Lift Capacities – Counterweight: 2470 kg (5,445 lb) – without Bucket – Blade Up

Long Undercarriage, 2500 mm (8'2") Blade

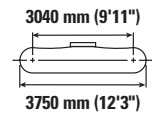
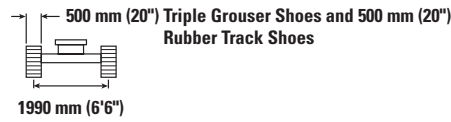
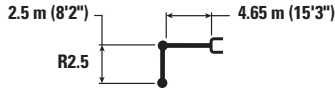

Reach	Unit	1.5 m/5.0 ft		3.0 m/10.0 ft		4.5 m/15.0 ft		6.0 m/20.0 ft		m ft/in		
6.0 m 20'0"	kg lb					*3550 *7,900	*3550 *7,900			*2600 *5,800	*2600 *5,800	5.44 17'6"
4.5 m 15'0"	kg lb					*3800 *8,300	*3800 *8,300	*3650 *7,400	2550 5,450	*2450 *5,350	2300 5,050	6.41 20'10"
3.0 m 10'0"	kg lb			*6400 *13,700	*6400 *13,700	*4650 *10,100	3850 8,250	3650 7,800	2500 5,350	*2450 *5,300	2000 4,350	6.93 22'8"
1.5 m 5'0"	kg lb			*7350 *18,000	6400 13,800	5450 11,750	3600 7,700	3500 7,550	2400 5,100	*2550 *5,600	1850 4,100	7.09 23'3"
0.0 m 0'0"	kg lb			*6500 *15,000	6100 13,100	5250 11,300	3400 7,300	3400 7,350	2300 4,900	2800 6,100	1900 4,150	6.93 22'8"
-1.5 m -5'0"	kg lb	*4800 *10,700	*4800 *10,700	*9600 *20,750	6050 13,000	5200 11,100	3350 7,150	3400 7,300	2250 4,850	3100 6,800	2100 4,600	6.41 20'11"
-3.0 m -10'0"	kg lb	*8850 *20,000	*8850 *20,000	*8250 *17,750	6150 13,200	5200 11,200	3350 7,250			3950 8,800	2650 5,850	5.43 17'8"

Reach Boom Lift Capacities – Counterweight: 2470 kg (5,445 lb) – without Bucket – Blade Up

Long Undercarriage, 2500 mm (8'2") Blade

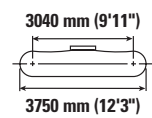
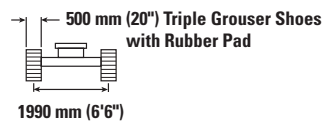
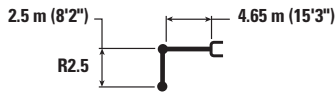

Reach	Unit	1.5 m/5.0 ft		3.0 m/10.0 ft		4.5 m/15.0 ft		6.0 m/20.0 ft		m ft/in		
6.0 m 20'0"	kg lb					*3550 *7,900	*3550 *7,900			*2600 *5,800	*2600 *5,800	5.44 17'6"
4.5 m 15'0"	kg lb					*3800 *8,300	*3800 *8,300	*3650 *7,400	2650 5,650	*2450 *5,350	2350 5,200	6.41 20'10"
3.0 m 10'0"	kg lb			*6400 *13,700	*6400 *13,700	*4650 *10,100	3950 8,500	3750 8,050	2550 5,500	*2450 *5,300	2050 4,500	6.93 22'8"
1.5 m 5'0"	kg lb			*7350 *18,000	6600 14,250	5650 12,150	3700 7,950	3650 7,850	2450 5,300	*2550 *5,600	1950 4,250	7.09 23'3"
0.0 m 0'0"	kg lb			*6500 *15,000	6300 13,550	5450 11,700	3500 7,550	3550 7,650	2400 5,100	*2850 *6,250	1950 4,300	6.93 22'8"
-1.5 m -5'0"	kg lb	*4800 *10,700	*4800 *10,700	*9600 *20,750	6250 13,450	5400 11,550	3450 7,400	3500 7,550	2350 5,050	3200 7,100	2150 4,750	6.41 20'11"
-3.0 m -10'0"	kg lb	*8850 *20,000	*8850 *20,000	*8250 *17,750	6350 13,650	5400 11,650	3500 7,500			4100 9,150	2750 6,050	5.43 17'8"



ISO 10567:2007



* Indicates that the load is limited by hydraulic lifting capacity rather than tipping load. The above loads are in compliance with hydraulic excavator lift capacity standard ISO 10567:2007. They do not exceed 87% of hydraulic lifting capacity or 75% of tipping load. Weight of all lifting accessories must be deducted from the above lifting capacities. Lifting capacities are based on the machine standing on a firm, uniform supporting surface. The use of a work tool attachment point to handle/lift objects, could affect the machine lift performance.

Lift capacity stays with ±5% for all available track shoes.

Always refer to the appropriate Operation and Maintenance Manual for specific product information.

313 GC Hydraulic Excavator Specifications

Reach Boom Lift Capacities – Counterweight: 2470 kg (5,445 lb) – without Bucket – Blade Up

Long Undercarriage, 2600 mm (8'6") Blade

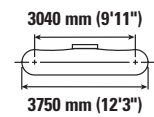
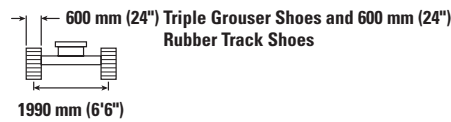
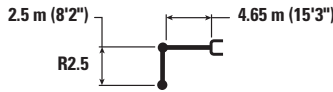

Reach Boom	Unit	1.5 m/5.0 ft		3.0 m/10.0 ft		4.5 m/15.0 ft		6.0 m/20.0 ft		Blade		m ft/in
		Hydraulic	Tipping	Hydraulic	Tipping	Hydraulic	Tipping	Hydraulic	Tipping	Hydraulic	Tipping	
6.0 m 20'0"	kg lb					*3550 *7,900	*3550 *7,900			*2600 *5,800	*2600 *5,800	5.44 17'6"
4.5 m 15'0"	kg lb					*3800 *8,300	*3800 *8,300	*3650 *7,400	2600 5,600	*2450 *5,350	2350 5,150	6.41 20'10"
3.0 m 10'0"	kg lb			*6400 *13,700	*6400 *13,700	*4650 *10,100	3900 8,400	3700 7,950	2550 5,450	*2450 *5,300	2000 4,450	6.93 22'8"
1.5 m 5'0"	kg lb			*7350 *18,000	6550 14,050	5550 11,950	3650 7,850	3600 7,700	2450 5,200	*2550 *5,600	1900 4,150	7.09 23'3"
0.0 m 0'0"	kg lb			*6500 *15,000	6250 13,350	5350 11,500	3450 7,450	3500 7,500	2350 5,050	2850 6,250	1950 4,250	6.93 22'8"
-1.5 m -5'0"	kg lb	*4800 *10,700	*4800 *10,700	*9600 *20,750	6200 13,300	5300 11,300	3400 7,300	3450 7,400	2300 4,950	3150 6,950	2150 4,700	6.41 20'11"
-3.0 m -10'0"	kg lb	*8850 *20,000	*8850 *20,000	*8250 *17,750	6300 13,500	5300 11,450	3450 7,400			4050 9,000	2700 6,000	5.43 17'8"

Reach Boom Lift Capacities – Counterweight: 2470 kg (5,445 lb) – without Bucket – Blade Up

Long Undercarriage, 2700 mm (8'10") Blade

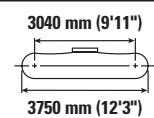
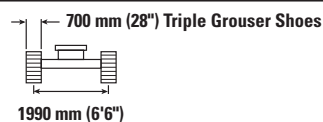
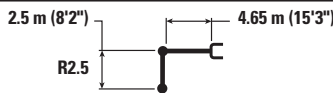

Reach Boom	Unit	1.5 m/5.0 ft		3.0 m/10.0 ft		4.5 m/15.0 ft		6.0 m/20.0 ft		Blade		m ft/in
		Hydraulic	Tipping	Hydraulic	Tipping	Hydraulic	Tipping	Hydraulic	Tipping	Hydraulic	Tipping	
6.0 m 20'0"	kg lb					*3550 *7,900	*3550 *7,900			*2600 *5,800	*2600 *5,800	5.44 17'6"
4.5 m 15'0"	kg lb					*3800 *8,300	*3800 *8,300	*3650 *7,400	2650 5,650	*2450 *5,350	2350 5,250	6.41 20'10"
3.0 m 10'0"	kg lb			*6400 *13,700	*6400 *13,700	*4650 *10,100	3950 8,500	3750 8,050	2550 5,500	*2450 *5,300	2050 4,500	6.93 22'8"
1.5 m 5'0"	kg lb			*7350 *18,000	6650 14,250	5650 12,100	3700 7,950	3650 7,800	2450 5,300	*2550 *5,600	1950 4,250	7.09 23'3"
0.0 m 0'0"	kg lb			*6500 *15,000	6300 13,550	5450 11,650	3500 7,550	3550 7,600	2400 5,100	*2850 *6,250	1950 4,300	6.93 22'8"
-1.5 m -5'0"	kg lb	*4800 *10,700	*4800 *10,700	*9600 *20,750	6300 13,450	5350 11,500	3450 7,400	3500 7,500	2350 5,050	3200 7,050	2150 4,750	6.41 20'11"
-3.0 m -10'0"	kg lb	*8850 *20,000	*8850 *20,000	*8250 *17,750	6400 13,700	5400 11,600	3500 7,500			4100 9,100	2750 6,050	5.43 17'8"



ISO 10567:2007



* Indicates that the load is limited by hydraulic lifting capacity rather than tipping load. The above loads are in compliance with hydraulic excavator lift capacity standard ISO 10567:2007. They do not exceed 87% of hydraulic lifting capacity or 75% of tipping load. Weight of all lifting accessories must be deducted from the above lifting capacities. Lifting capacities are based on the machine standing on a firm, uniform supporting surface. The use of a work tool attachment point to handle/lift objects, could affect the machine lift performance.

Lift capacity stays with ±5% for all available track shoes.









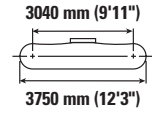
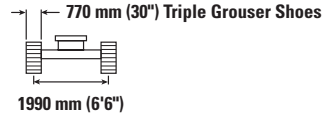
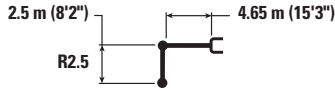

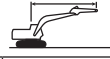
Always refer to the appropriate Operation and Maintenance Manual for specific product information.

313 GC Hydraulic Excavator Specifications

Reach Boom Lift Capacities – Counterweight: 2470 kg (5,445 lb) – without Bucket – Blade Up

Long Undercarriage, 2700 mm (8'10") Blade



		1.5 m/5.0 ft		3.0 m/10.0 ft		4.5 m/15.0 ft		6.0 m/20.0 ft				m ft/in
												
6.0 m 20'0"	kg lb					*3550 *7,900	*3550 *7,900			*2600 *5,800	*2600 *5,800	5.44 17'6"
4.5 m 15'0"	kg lb					*3800 *8,300	*3800 *8,300	*3650 *7,400	2650 5,700	*2450 *5,350	2400 5,300	6.41 20'10"
3.0 m 10'0"	kg lb			*6400 *13,700	*6400 *13,700	*4650 *10,100	4000 8,600	3800 8,100	2600 5,550	*2450 *5,300	2050 4,550	6.93 22'8"
1.5 m 5'0"	kg lb			*7350 *18,000	6700 14,400	*5700 *12,250	3750 8,050	3650 7,900	2500 5,350	*2550 *5,600	1950 4,300	7.09 23'3"
0.0 m 0'0"	kg lb			*6500 *15,000	6400 13,700	5500 11,800	3550 7,650	3600 7,700	2400 5,150	*2850 *6,250	2000 4,350	6.93 22'8"
-1.5 m -5'0"	kg lb	*4800 *10,700	*4800 *10,700	*9600 *20,750	6350 13,600	5400 11,600	3500 7,500	3550 7,600	2400 5,100	3250 7,150	2200 4,800	6.41 20'11"
-3.0 m -10'0"	kg lb	*8850 *20,000	*8850 *20,000	*8250 *17,750	6450 13,850	5450 11,700	3550 7,600			4150 9,200	2750 6,150	5.43 17'8"



ISO 10567:2007



* Indicates that the load is limited by hydraulic lifting capacity rather than tipping load. The above loads are in compliance with hydraulic excavator lift capacity standard ISO 10567:2007. They do not exceed 87% of hydraulic lifting capacity or 75% of tipping load. Weight of all lifting accessories must be deducted from the above lifting capacities. Lifting capacities are based on the machine standing on a firm, uniform supporting surface. The use of a work tool attachment point to handle/lift objects, could affect the machine lift performance.

Lift capacity stays with ±5% for all available track shoes.

Always refer to the appropriate Operation and Maintenance Manual for specific product information.

313 GC Hydraulic Excavator Specifications

Reach Boom Lift Capacities – Counterweight: 2470 kg (5,445 lb) – without Bucket – Blade Up

Long Undercarriage, 2500 mm (8'2") Blade

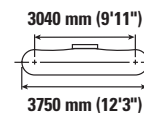

		1.5 m/5.0 ft		3.0 m/10.0 ft		4.5 m/15.0 ft		6.0 m/20.0 ft		7.5 m/25.0 ft		m ft/in		
7.5 m 25'0"	kg lb											*2600 *5,850	*2600 *5,850	4.49 14'1"
6.0 m 20'0"	kg lb							*2250	*2250			*2200 *4,850	*2200 *4,850	6.03 19'6"
4.5 m 15'0"	kg lb							*3350 *7,300	2600 5,550			*2050 *4,500	2050 4,500	6.92 22'6"
3.0 m 10'0"	kg lb			*5350 *11,450	*5350 *11,450	*4200 *9,050	3900 8,350	3650 7,850	2500 5,350			*2050 *4,500	1800 3,900	7.4 24'2"
1.5 m 5'0"	kg lb			*8200 *17,650	6550 14,150	*5300 *11,400	3600 7,750	3550 7,550	2400 5,100	*2400	1700	*2150 *4,750	1700 3,700	7.55 24'9"
0.0 m 0'0"	kg lb			*7250 *16,750	6100 13,100	5250 11,300	3400 7,300	3400 7,300	2300 4,900			*2400 *5,250	1700 3,700	7.4 24'3"
-1.5 m -5'0"	kg lb	*4350 *9,700	*4350 *9,700	*9200 *21,000	6000 12,850	5150 11,050	3300 7,050	3350 7,200	2200 4,750			2750 6,050	1850 4,050	6.91 22'7"
-3.0 m -10'0"	kg lb	*7450 *16,800	*7450 *16,800	*8800 *19,050	6050 12,950	5150 11,050	3300 7,050	3350	2250			3350 7,450	2250 4,950	6.02 19'7"
-4.5 m -15'0"	kg lb			*6400 *13,550	6250 13,450							*4000 *8,800	3450 7,900	4.48 14'4"

Reach Boom Lift Capacities – Counterweight: 2470 kg (5,445 lb) – without Bucket – Blade Up

Long Undercarriage, 2500 mm (8'2") Blade

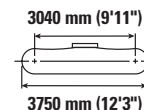
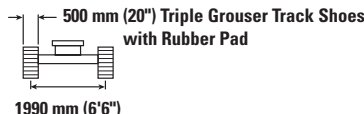

		1.5 m/5.0 ft		3.0 m/10.0 ft		4.5 m/15.0 ft		6.0 m/20.0 ft		7.5 m/25.0 ft		m ft/in		
7.5 m 25'0"	kg lb											*2600 *5,850	*2600 *5,850	4.49 14'1"
6.0 m 20'0"	kg lb							*2250	*2250			*2200 *4,850	*2200 *4,850	6.03 19'6"
4.5 m 15'0"	kg lb							*3350 *7,300	2650 5,700			*2050 *4,500	*2050 *4,500	6.92 22'6"
3.0 m 10'0"	kg lb			*5350 *11,450	*5350 *11,450	*4200 *9,050	4000 8,600	*3700 *8,000	2600 5,550			*2050 *4,500	1850 4,050	7.4 24'2"
1.5 m 5'0"	kg lb			*8200 *17,650	6800 14,600	*5300 *11,400	3750 8,050	3650 7,850	2450 5,300	*2400	1750	*2150 *4,750	1750 3,800	7.55 24'9"
0.0 m 0'0"	kg lb			*7250 *16,750	6300 13,550	5450 11,700	3500 7,550	3550 7,600	2350 5,050			*2400 *5,250	1750 3,850	7.4 24'3"
-1.5 m -5'0"	kg lb	*4350 *9,700	*4350 *9,700	*9200 *21,000	6200 13,300	5350 11,450	3400 7,300	3500 7,450	2300 4,950			*2850 *6,250	1900 4,200	6.91 22'7"
-3.0 m -10'0"	kg lb	*7450 *16,800	*7450 *16,800	*8800 *19,050	6250 13,400	5350 11,450	3400 7,300	3500	2350			3500 7,750	2300 5,150	6.02 19'7"
-4.5 m -15'0"	kg lb			*6400 *13,550	*6400 *13,550							*4000 *8,800	3600 8,200	4.48 14'4"



ISO 10567:2007



* Indicates that the load is limited by hydraulic lifting capacity rather than tipping load. The above loads are in compliance with hydraulic excavator lift capacity standard ISO 10567:2007. They do not exceed 87% of hydraulic lifting capacity or 75% of tipping load. Weight of all lifting accessories must be deducted from the above lifting capacities. Lifting capacities are based on the machine standing on a firm, uniform supporting surface. The use of a work tool attachment point to handle/lift objects, could affect the machine lift performance.

Lift capacity stays with ±5% for all available track shoes.

Always refer to the appropriate Operation and Maintenance Manual for specific product information.

313 GC Hydraulic Excavator Specifications

Reach Boom Lift Capacities – Counterweight: 2470 kg (5,445 lb) – without Bucket – Blade Up

Long Undercarriage, 2600 mm (8'6") Blade

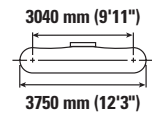
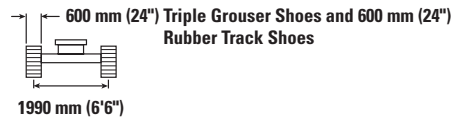
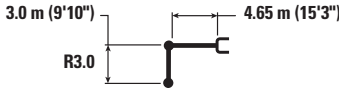

		1.5 m/5.0 ft		3.0 m/10.0 ft		4.5 m/15.0 ft		6.0 m/20.0 ft		7.5 m/25.0 ft		m ft/in		
7.5 m 25'0"	kg lb											*2600 *5,850	*2600 *5,850	4.49 14'1"
6.0 m 20'0"	kg lb							*2250	*2250			*2200 *4,850	*2200 *4,850	6.03 19'6"
4.5 m 15'0"	kg lb							*3350 *7,300	2650 5,650			*2050 *4,500	*2050 *4,500	6.92 22'6"
3.0 m 10'0"	kg lb			*5350 *11,450	*5350 *11,450	*4200 *9,050	3950 8,500	*3700 8,000	2550 5,500			*2050 *4,500	1800 4,000	7.4 24'2"
1.5 m 5'0"	kg lb			*8200 *17,650	6700 14,400	*5300 *11,400	3700 7,950	3600 7,700	2450 5,250	*2400	1750	*2150 *4,750	1700 3,750	7.55 24'9"
0.0 m 0'0"	kg lb			*7250 *16,750	6250 13,400	5350 11,500	3450 7,450	3450 7,450	2350 5,000			*2400 *5,250	1750 3,800	7.4 24'3"
-1.5 m -5'0"	kg lb	*4350 *9,700	*4350 *9,700	*9200 *21,000	6100 13,100	5250 11,250	3350 7,200	3400 7,300	2250 4,900			2800 6,150	1900 4,150	6.91 22'7"
-3.0 m -10'0"	kg lb	*7450 *16,800	*7450 *16,800	*8800 *19,050	6150 13,250	5250 11,250	3350 7,250	3450	2300			3450 7,600	2300 5,050	6.02 19'7"
-4.5 m -15'0"	kg lb			*6400 *13,550	6400 *13,550							*4000 *8,800	3550 8,100	4.48 14'4"

Reach Boom Lift Capacities – Counterweight: 2470 kg (5,445 lb) – without Bucket – Blade Up

Long Undercarriage, 2700 mm (8'10") Blade

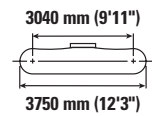
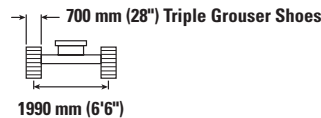
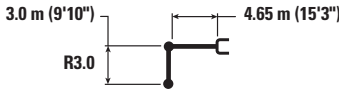

		1.5 m/5.0 ft		3.0 m/10.0 ft		4.5 m/15.0 ft		6.0 m/20.0 ft		7.5 m/25.0 ft		m ft/in		
7.5 m 25'0"	kg lb											*2600 *5,850	*2600 *5,850	4.49 14'1"
6.0 m 20'0"	kg lb							*2250	*2250			*2200 *4,850	*2200 *4,850	6.03 19'6"
4.5 m 15'0"	kg lb							*3350 *7,300	2700 5,750			*2050 *4,500	*2050 *4,500	6.92 22'6"
3.0 m 10'0"	kg lb			*5350 *11,450	*5350 *11,450	*4200 *9,050	4000 8,650	*3700 *8,000	2600 5,550			*2050 *4,500	1850 4,050	7.4 24'2"
1.5 m 5'0"	kg lb			*8200 *17,650	6800 14,600	*5300 *11,400	3750 8,050	3650 7,800	2450 5,300	*2400	1750	*2150 *4,750	1750 3,850	7.55 24'9"
0.0 m 0'0"	kg lb			*7250 *16,750	6350 13,600	5450 11,650	3500 7,550	3500 7,550	2350 5,050			*2400 *5,250	1750 3,850	7.4 24'3"
-1.5 m -5'0"	kg lb	*4350 *9,700	*4350 *9,700	*9200 *21,000	6200 13,300	5300 11,400	3400 7,350	3450 7,450	2300 4,950			*2850 *6,250	1900 4,200	6.91 22'7"
-3.0 m -10'0"	kg lb	*7450 *16,800	*7450 *16,800	*8800 *19,050	6250 13,450	5300 11,400	3400 7,350	3500	2350			3500 7,700	2350 5,150	6.02 19'7"
-4.5 m -15'0"	kg lb			*6400 *13,550	6400 *13,550							*4000 *8,800	3600 8,200	4.48 14'4"



ISO 10567:2007



* Indicates that the load is limited by hydraulic lifting capacity rather than tipping load. The above loads are in compliance with hydraulic excavator lift capacity standard ISO 10567:2007. They do not exceed 87% of hydraulic lifting capacity or 75% of tipping load. Weight of all lifting accessories must be deducted from the above lifting capacities. Lifting capacities are based on the machine standing on a firm, uniform supporting surface. The use of a work tool attachment point to handle/lift objects, could affect the machine lift performance.

Lift capacity stays with ±5% for all available track shoes.

Always refer to the appropriate Operation and Maintenance Manual for specific product information.

313 GC Hydraulic Excavator Specifications

Reach Boom Lift Capacities – Counterweight: 2470 kg (5,445 lb) – without Bucket – Blade Up

Long Undercarriage, 2700 mm (8'10") Blade

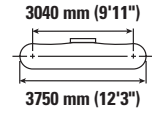
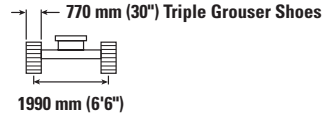
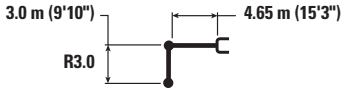

Reach	Unit	1.5 m/5.0 ft		3.0 m/10.0 ft		4.5 m/15.0 ft		6.0 m/20.0 ft		7.5 m/25.0 ft		m ft/in		
		kg lb	kg lb	kg lb	kg lb	kg lb	kg lb	kg lb	kg lb	kg lb	kg lb	kg lb	kg lb	
7.5 m 25'0"	kg lb											*2600 *5,850	*2600 *5,850	4.49 14'1"
6.0 m 20'0"	kg lb							*2250 *2250				*2200 *4,850	*2200 *4,850	6.03 19'6"
4.5 m 15'0"	kg lb							*3350 *7,300	2700 5,800			*2050 *4,500	*2050 *4,500	6.92 22'6"
3.0 m 10'0"	kg lb			*5350 *11,450	*5350 *11,450	*4200 *9,050	4050 8,700	*3700 *8,000	2600 5,600			*2050 *4,500	1850 4,100	7.40 24'2"
1.5 m 5'0"	kg lb			*8200 *17,650	6850 14,750	*5300 *11,400	3800 8,100	3700 7,900	2500 5,350	*2400 1800		*2150 *4,750	1750 3,850	7.55 24'9"
0.0 m 0'0"	kg lb			*7250 *16,750	6400 13,750	5500 11,800	3550 7,650	3550 7,650	2400 5,150			*2400 *5,250	1800 3,900	7.40 24'3"
-1.5 m -5'0"	kg lb	*4350 *9,700	*4350 *9,700	*9200 *21,000	6250 13,450	5350 11,550	3450 7,400	3500 7,500	2350 5,000			*2850 *6,250	1950 4,250	6.91 22'7"
-3.0 m -10'0"	kg lb	*7450 *16,800	*7450 *16,800	*8800 *19,050	6300 13,550	5400 11,550	3450 7,400	3550 7,400	2350 5,000			3500 7,800	2350 5,200	6.02 19'7"
-4.5 m -15'0"	kg lb			*6400 *13,550	*6400 *13,550							*4000 *8,800	3650 8,250	4.48 14'4"



ISO 10567:2007



* Indicates that the load is limited by hydraulic lifting capacity rather than tipping load. The above loads are in compliance with hydraulic excavator lift capacity standard ISO 10567:2007. They do not exceed 87% of hydraulic lifting capacity or 75% of tipping load. Weight of all lifting accessories must be deducted from the above lifting capacities. Lifting capacities are based on the machine standing on a firm, uniform supporting surface. The use of a work tool attachment point to handle/lift objects, could affect the machine lift performance.

Lift capacity stays with ±5% for all available track shoes.

Always refer to the appropriate Operation and Maintenance Manual for specific product information.

313 GC Hydraulic Excavator Specifications

Bucket Specifications and Compatibility

										2470 kg (5,445 lb) Counterweight	
		mm	in	m ³	yd ³	kg	lb	%	Reach Boom		
									R2.5 (8'2")	R3.0 (9'10")	
Pin-On (No Quick Coupler)											
General Duty	312	600	24	0.31	0.40	316	696	100	●	●	
	312	900	36	0.53	0.69	414	914	100	●	●	
	312	1000	39	0.60	0.78	438	967	100	●	●	
	312	1100	43	0.68	0.89	474	1,045	100	●	⊙	
General Duty (without Adjuster Gp)	312	450	18	0.20	0.26	266	587	100	●	●	
	312	600	24	0.31	0.40	310	684	100	●	●	
	312	750	30	0.41	0.54	358	790	100	●	●	
	312	900	36	0.53	0.69	407	898	100	●	●	
Heavy Duty	312	450	18	0.20	0.27	279	615	100	●	●	
	312	1200	48	0.76	0.99	513	1,131	100	⊙	⊖	
Ditch Cleaning	312	1800	72	0.68	0.89	540	1,191	100	⊙	⊖	
Ditch Cleaning Tilt	312	1800	72	0.60	0.78	724	1,597	100	⊙	⊖	
								kg	1850	1640	
Maximum load pin-on (payload + bucket)								lb	4,075	3,612	
With Cat Pin Grabber Coupler											
General Duty	312	600	24	0.31	0.40	316	696	100	●	●	
	312	900	36	0.53	0.69	414	914	100	●	⊙	
	312	1000	39	0.60	0.78	438	967	100	●	⊖	
	312	1100	43	0.68	0.89	474	1,045	100	⊙	○	
	312	1200	48	0.76	1.00	504	1,110	100	⊖	○	
General Duty	312	450	18	0.20	0.26	266	587	100	●	●	
	312	600	24	0.31	0.40	310	684	100	●	●	
	312	750	30	0.41	0.54	358	790	100	●	●	
	312	900	36	0.53	0.69	407	898	100	●	⊙	
	312	1050	42	0.65	0.84	457	1,006	100	⊙	⊖	
Heavy Duty	312	450	18	0.20	0.27	279	615	100	●	●	
	312	1200	48	0.76	0.99	513	1,131	100	⊖	○	
Ditch Cleaning	312	1800	72	0.68	0.89	540	1,191	100	⊖	○	
Ditch Cleaning Tilt	312	1800	72	0.60	0.78	724	1,597	100	⊖	○	
								kg	1649	1439	
Maximum load with coupler (payload + bucket)								lb	3,635	3,172	

The above loads are in compliance with hydraulic excavator standard EN474-5:2006 + A3:2013, they do not exceed 87% of hydraulic lifting capacity or 75% of tipping capacity with front linkage fully extended at ground line with bucket curled.

Capacity based on ISO 7451:2007.

Bucket weight with General Duty tips.

Maximum Material Density:

- 2100 kg/m³ (3,500 lb/yd³)
- ⊙ 1800 kg/m³ (3,000 lb/yd³)
- ⊖ 1500 kg/m³ (2,500 lb/yd³)
- 1200 kg/m³ (2,000 lb/yd³)

Caterpillar recommends using appropriate work tools to maximize the value customers receive from our products. Use of work tools, including buckets, which are outside of Caterpillar's recommendations or specifications for weight, dimensions, flows, pressures, etc. may result in less-than-optimal performance, including but not limited to reductions in production, stability, reliability, and component durability. Improper use of a work tool resulting in sweeping, prying, twisting and/or catching of heavy loads will reduce the life of the boom and stick.

(continued on next page)

313 GC Hydraulic Excavator Specifications

Bucket Specifications and Compatibility (continued)

										2470 kg (5,445 lb) Counterweight	
		mm	in	m ³	yd ³	kg	lb	%	Reach Boom		
									R2.5 (8'2")	R3.0 (9'10")	
With CW20 Coupler											
General Duty	312	600	24	0.31	0.40	341	752	100	●	●	
	312	900	36	0.53	0.69	426	940	100	●	⊙	
	312	1100	43	0.68	0.89	487	1,073	100	⊖	○	
	312	1200	48	0.76	1.00	516	1,137	100	⊖	○	
Heavy Duty	312	1200	48	0.76	1.00	526	1,159	100	⊖	○	
General Duty – Leveling Edge	312	690	27	0.40	0.52	413	910	100	●	●	
	312	600	24	0.33	0.43	395	870	100	●	●	
	312	790	31	0.47	0.61	455	1,003	100	●	●	
	312	996	39	0.63	0.83	517	1,140	100	⊙	⊖	
Ditch Cleaning	312	1184	47	0.80	1.05	603	1,328	100	○	◇	
	312	1800	72	0.68	0.89	516	1,138	100	⊖	○	
	312	1800	72	0.90	1.18	554	1,221	100	○	◇	
Maximum load with coupler (payload + bucket)									kg	1643	1434
									lb	3,623	3,160
With CW20S Coupler											
General Duty	312	450	18	0.20	0.26	301	664	100	●	●	
	312	500	20	0.24	0.31	310	684	100	●	●	
	312	600	24	0.31	0.40	329	726	100	●	●	
	312	750	30	0.41	0.54	377	830	100	●	●	
	312	900	36	0.53	0.69	426	940	100	●	⊙	
	312	1000	39	0.60	0.78	451	995	100	●	⊖	
	312	1100	43	0.68	0.89	487	1,073	100	⊙	○	
	312	1200	48	0.76	1.00	516	1,137	100	⊖	○	
Heavy Duty	312	500	20	0.24	0.31	313	689	100	●	●	
	312	1200	48	0.76	1.00	524	1,154	100	○	○	
Ditch Cleaning	312	1800	72	0.68	0.89	548	1,207	100	○	○	
	312	2000	78	1.00	1.31	630	1,389	100	◇	X	
Ditch Cleaning Tilt	312	1800	72	0.60	0.78	822	1,812	100	○	◇	
Maximum load with coupler (payload + bucket)									kg	1665	1456
									lb	3,672	3,209

The above loads are in compliance with hydraulic excavator standard EN474-5:2006 + A3:2013, they do not exceed 87% of hydraulic lifting capacity or 75% of tipping capacity with front linkage fully extended at ground line with bucket curled.

Capacity based on ISO 7451:2007.

Bucket weight with General Duty tips.

Maximum Material Density:

- 2100 kg/m³ (3,500 lb/yd³)
- ⊙ 1800 kg/m³ (3,000 lb/yd³)
- ⊖ 1500 kg/m³ (2,500 lb/yd³)
- 1200 kg/m³ (2,000 lb/yd³)
- ◇ 900 kg/m³ (1,500 lb/yd³)

Caterpillar recommends using appropriate work tools to maximize the value customers receive from our products. Use of work tools, including buckets, which are outside of Caterpillar's recommendations or specifications for weight, dimensions, flows, pressures, etc. may result in less-than-optimal performance, including but not limited to reductions in production, stability, reliability, and component durability. Improper use of a work tool resulting in sweeping, prying, twisting and/or catching of heavy loads will reduce the life of the boom and stick.

313 GC Hydraulic Excavator Specifications

Attachments Offering Guide – Europe

Not all Attachments are available in all regions. Consult your Cat dealer for configurations available in your region.

Match

* Working range front only

No Match

1200 kg/m³ (2,000 lb/yd³)

PIN-ON ATTACHMENTS

Counterweight		2470 kg (5,445 lb)	
Boom Type		Reach	
Stick Length		2.50 m (8'2")	3.00 m (9'10")
Hydraulic Hammers	H110 GC S	✓	✓
	H110 S	✓	✓
	H115 GC S	✓	✓
	H115 S	✓	✓
Demolition and Sorting Grapples	G312 GC	✓	✓
	G313 GC	✓	✓*
	G314	✓	
Mobile Scrap and Demolition Shears	S3015 Flat Top	✓	
Compactors (Vibratory Plate)	CVP75	✓	✓
Rotary Cutters	RC10	✓	✓
Orange Peel Grapples	GSV520 GC-400	○	

CAT PIN GRABBER COUPLER ATTACHMENTS

Counterweight		2470 kg (5,445 lb)	
Boom Type		Reach	
Stick Length		2.50 m (8'2")	3.00 m (9'10")
Hydraulic Hammers	H110 GC S	✓	✓
	H110 S	✓	✓
	H115 GC S	✓	✓*
	H115 S	✓	✓
Demolition and Sorting Grapples	G312 GC	✓	
Compactors (Vibratory Plate)	CVP75	✓	✓
Rotary Cutters	RC10	✓	✓

CW-20s DEDICATED COUPLER ATTACHMENTS

Counterweight		2470 kg (5,445 lb)	
Boom Type		Reach	
Stick Length		2.50 m (8'2")	3.00 m (9'10")
Hydraulic Hammers	H110 GC S	✓	✓
	H110 S	✓	✓
	H115 GC S	✓*	
	H115 S	✓	✓
Demolition and Sorting Grapples	G312 GC	✓	✓*
	G313 GC	✓*	
Compactors (Vibratory Plate)	CVP75	✓	✓
Rotary Cutters	RC10	✓	✓

(continued on next page)

313 GC Hydraulic Excavator Specifications

Attachments Offering Guide – Europe (continued)

Not all Attachments are available in all regions. Consult your Cat dealer for configurations available in your region.

Match

* Working range front only

No Match

CW-20 DEDICATED COUPLER ATTACHMENTS

Counterweight		2470 kg (5,445 lb)	
Boom Type		Reach	
Stick Length		2.50 m (8'2")	3.00 m (9'10")
Hydraulic Hammers	H110 GC S	✓	✓
	H110 S	✓	✓
	H115 GC S	✓	
	H115 S	✓	✓
Demolition and Sorting Grapples	G312 GC	✓	✓*
	G312 GC Fixed CAN	✓	✓*
	G313 GC	✓*	
	G312 GC Fixed CAN	✓	
Compactors (Vibratory Plate)	CVP75	✓	✓
Rotary Cutters	RC10	✓	✓

HCCW20 COUPLER ATTACHMENTS

Counterweight		2470 kg (5,445 lb)	
Boom Type		Reach	
Stick Length		2.20 m (7'3")	2.50 m (8'2")
Hydraulic Hammers	H110 GC S	✓*	
	H110 S	✓	
	H115 S	✓*	
Compactors (Vibratory Plate)	CVP75	✓	✓
Rotary Cutters	RC10	✓	✓

S60 DEDICATED COUPLER ATTACHMENTS

Counterweight		2470 kg (5,445 lb)	
Boom Type		Reach	
Stick Length		2.50 m (8'2")	3.00 m (9'10")
Hydraulic Hammers	H110 GC S	✓	✓
	H110 S	✓	✓
	H115 GC S	✓	✓
	H115 S	✓	✓
Demolition and Sorting Grapples	G312 GC	✓	✓*
	G313 GC	✓*	
	G314	✓*	
Mobile Scrap and Demolition Shears	S3015 Flat Top	✓*	
Compactors (Vibratory Plate)	CVP75	✓	✓
Rotary Cutters	RC10	✓	✓

(continued on next page)

313 GC Hydraulic Excavator Specifications

Attachments Offering Guide – Europe (continued)

Not all Attachments are available in all regions. Consult your Cat dealer for configurations available in your region.

Match

* Working range front only

No Match

HCS60 DEDICATED COUPLER ATTACHMENTS

Counterweight		2470 kg (5,445 lb)	
Boom Type		Reach	
Stick Length		2.50 m (8'2")	3.00 m (9'10")
Hydraulic Hammers	H110 S	✓	✓
	H115 S	✓	✓
Demolition and Sorting Grapples	G312 GC	✓	
Compactors (Vibratory Plate)	CVP75	✓	✓
Rotary Cutters	RC10	✓	✓

HCS65 DEDICATED COUPLER ATTACHMENTS

Counterweight		2470 kg (5,445 lb)	
Boom Type		Reach	
Stick Length		2.50 m (8'2")	3.00 m (9'10")
Hydraulic Hammers	H110 S	✓	✓
	H115 S	✓	✓
Demolition and Sorting Grapples	G312 GC	✓*	
Compactors (Vibratory Plate)	CVP75	✓	✓
Rotary Cutters	RC10	✓	✓

BOOM-MOUNT ATTACHMENTS

Counterweight		2470 kg (5,445 lb)	
Boom Type		Reach	
Mobile Scrap and Demolition Shears	S3025 Flat Top		✓

313 GC Hydraulic Excavator Specifications

Attachments Offering Guide – Türkiye

Not all Attachments are available in all regions. Consult your Cat dealer for configurations available in your region.

Match

* Working range front only

No Match

1200 kg/m³ (2,000 lb/yd³)

PIN-ON ATTACHMENTS

Counterweight	2470 kg (5,445 lb)	
Boom Type	Reach	
Stick Length	2.50 m (8'2")	
Hydraulic Hammers	H110 GC	✓
	H110 GC Side Mount	✓
	H110 GC S	✓
	H110 S	✓
	H115 GC	✓
	H115 GC S	✓
	H115 S	✓
Demolition and Sorting Grapples	G312 GC	✓
	G313 GC	✓
	G314	✓
Mobile Scrap and Demolition Shears	S3015 Flat Top	✓
Compactors (Vibratory Plate)	CVP75	✓
Orange Peel Grapples	GSV520 GC-400	○

CAT PIN GRABBER COUPLER ATTACHMENTS

Counterweight	2470 kg (5,445 lb)	
Boom Type	Reach	
Stick Length	2.50 m (8'2")	
Hydraulic Hammers	H110 GC	✓
	H110 GC Side Mount	✓
	H110 GC S	✓
	H110 S	✓
	H115 GC	✓
	H115 GC S	✓
	H115 S	✓
Demolition and Sorting Grapples	G312 GC	✓
Compactors (Vibratory Plate)	CVP75	✓

(continued on next page)

313 GC Hydraulic Excavator Specifications

Attachments Offering Guide – Türkiye (continued)

Not all Attachments are available in all regions. Consult your Cat dealer for configurations available in your region.

Match * Working range front only

CW-20s DEDICATED COUPLER ATTACHMENTS

Counterweight	2470 kg (5,445 lb)	
Boom Type	Reach	
Stick Length	2.50 m (8'2")	
Hydraulic Hammers	H110 GC	✓
	H110 GC S	✓
	H110 S	✓
	H115 GC	✓*
	H115 GC S	✓*
	H115 S	✓
Demolition and Sorting Grapples	G312 GC	✓
	G313 GC	✓*
Compactors (Vibratory Plate)	CVP75	✓

CW-20 DEDICATED COUPLER ATTACHMENTS

Counterweight	2470 kg (5,445 lb)	
Boom Type	Reach	
Stick Length	2.50 m (8'2")	
Hydraulic Hammers	H110 GC	✓
	H110 GC S	✓
	H110 S	✓
	H115 GC	✓*
	H115 GC S	✓
	H115 S	✓
Demolition and Sorting Grapples	G312 GC	✓
	G312 GC Fixed CAN	✓
	G313 GC	✓*
	G312 GC Fixed CAN	✓
Compactors (Vibratory Plate)	CVP75	✓

BOOM-MOUNT ATTACHMENTS

Counterweight	2470 kg (5,445 lb)	
Boom Type	Reach	
Mobile Scrap and Demolition Shears	S3025 Flat Top	✓

Standard and Optional Equipment

Standard and optional equipment may vary. Consult your Cat dealer for details.

	Standard	Optional		Standard	Optional
BOOM, STICKS AND LINKAGE			CAT TECHNOLOGY		
4.65 m (15'3") Reach boom	✓		Cat Equipment Management:		
3.0 m (9'10") Reach stick		✓ ¹	– VisionLink®	✓ ⁴	
2.5 m (8'2") Reach stick		✓ ²	– VisionLink Productivity		✓ ⁵
Bucket linkage, with lifting eye	✓ ¹		– Remote Flash	✓	
Bucket linkage, without lifting eye	✓ ³		ELECTRICAL SYSTEM		
CAB			Maintenance free battery	✓	
ROPS	✓		Centralized electrical disconnect switch	✓	
Operator Protective Guards (OPG)		✓	LED chassis light, left-side boom light, cab lights	✓	
High-resolution 203 mm (8") LCD touchscreen monitor	✓		LED right-side boom light		✓
Auto bi-level air conditioner	✓		Programmable time-delay LED working lights	✓	
Jog dial and shortcut keys for monitor control	✓		360° lighting ¹		✓
Keyless push-to-start engine control	✓		ENGINE		
Height-adjustable console, three steps with tool	✓		Cat® C3.6 single turbo diesel engine	✓	
Fixed left-side console	✓		Two selectable modes: Power, Smart	✓	
Air-suspension seat	✓		Automatic engine speed control	✓	
51 mm (2") seat belt	✓		Auto engine shutdown	✓	
Bluetooth® radio with USB/Auxiliary ports/Digital Audio Broadcasting (DAB)	✓		52° C (125° F) high-ambient cooling capacity without de-rate	✓	
12V DC outlets	✓		–18° C (0° F) cold start capability	✓	
Document storage	✓		Electric fuel priming pump	✓	
Beverage holder	✓		Variable speed fan	✓	
Cup holder	✓		Single fuel filtration system	✓	
Openable two-piece front window	✓		Double element air filter with integrated pre-cleaner	✓	
Rear window emergency exit	✓				
Radial wiper with washer	✓				
Openable polycarbonate skylight hatch	✓				
LED dome light	✓				
Roller front sunscreen	✓				
Roller rear sunscreen		✓ ¹			
Washable floor mat	✓				
Beacon ready	✓				

(continued on next page)

¹Europe only

²Standard for Kingdom of Saudi Arabia and Türkiye

³Kingdom of Saudi Arabia and Türkiye only

⁴Provides core telematics data to manage health, maintenance insights, and condition monitoring. Other plans available for more comprehensive data reporting. Consult your Cat dealer for details.

⁵VisionLink subscription required. Consult your Cat dealer for details.

313 GC Standard and Optional Equipment

Standard and Optional Equipment (continued)

Standard and optional equipment may vary. Consult your Cat dealer for details.

	Standard	Optional		Standard	Optional
HYDRAULIC SYSTEM			UNDERCARRIAGE AND STRUCTURES		
Boom and stick regeneration circuits	✓		Grease lubricated track link	✓	
Automatic hydraulic oil warm up	✓		500 mm (20") triple grouser track shoes		✓ ²
Automatic two-speed travel	✓		500 mm (20") triple grouser track shoes with rubber pad		✓ ¹
Electric main control valve	✓		500 mm (20") rubber track shoes		✓ ¹
Boom and stick drift reduction valve	✓		600 mm (24") triple grouser track shoes		✓ ¹
Swing drive, without fine swing control function	✓		600 mm (24") rubber track shoes		✓ ¹
Boom and stick lowering check valves	✓ ¹		700 mm (28") triple grouser track shoes		✓ ¹
Medium-pressure line		✓ ¹	770 mm (30") triple grouser track shoes		✓ ¹
High-pressure line		✓ ²	2500 mm (8'2") blade		✓ ¹
Quick coupler line		✓ ¹	2600 mm (8'6") blade		✓ ¹
SAFETY AND SECURITY			2700 mm (8'10") blade		✓ ¹
Operator Protective Guards (OPG)		✓ ¹	2470 kg (5,445 lb) counterweight	✓	
Rear and right-side-view cameras	✓		Center track guiding guards	✓	
Hydraulic lock out lever	✓		Bottom guards	✓	
Ground level engine shutoff switch	✓		Travel motor guards	✓	
Service platform with anti-skid plate and countersunk bolts	✓		Tie-down points on base frame	✓	
Signaling/warning horn	✓				
Swing alarm		✓			
Inspection lighting		✓			
Auto Hammer Stop	✓				
SERVICE AND MAINTENANCE					
Grouped engine oil and fuel filters	✓				
Side entry to service platform	✓				
Ground level engine oil dipstick	✓				
Lockable disconnect switch	✓				
Scheduled Oil Sampling (S·O·S SM) ports	✓				
Integrated vehicle health management system	✓				

¹Europe only

²Standard for Kingdom of Saudi Arabia and Türkiye

Dealer Installed Kits and Attachments

Attachments may vary. Consult your Cat dealer for details.

CAB

- Radial lower wiper
- Left-hand and right-hand electrical pedal (two-way) for tool control
- Dual exit rear window kit
- Rain protector plus cab light cover
- Polycarbonate roof hatch
- Front windshield laminated glass (P5A glass, EU demolition regulation)
- Key fob (for use with Bluetooth receiver)

SAFETY AND SECURITY

- 76 mm (3") retractable seat belt
- Bluetooth receiver

GUARDS

- Operator Protective Guards (OPG) (not compatible with cab light cover, rain protector)
- Mesh guard full front (not compatible with cab light cover, rain protector)
- Mesh guard lower half front
- Full protecting vandalism guard

313 GC Environmental Declaration

The following information applies to the machine at the time of final manufacture as configured for sale in the regions covered in this document. The content of this declaration is valid as of the date issued; however, content related to machine features and specifications are subject to change without notice. For additional information, please see the machine's Operation and Maintenance Manual.

For more information on sustainability in action and our progress, please visit <https://www.caterpillar.com/en/company/sustainability>.

Engine

- The Cat® C3.6 engine meets U.S. EPA Tier 4 Final, EU Stage V, and Japan 2014 emission standards.
- Cat diesel engines are required to use ULSD (ultra-low sulfur diesel fuel with 15 ppm of sulfur or less) or ULSD blended with the following lower-carbon intensity fuels** up to:
 - ✓ 20% biodiesel FAME (fatty acid methyl ester)*
 - ✓ 100% renewable diesel, HVO (hydrotreated vegetable oil) and GTL (gas-to-liquid) fuels

Refer to guidelines for successful application. Please consult your Cat dealer or "Caterpillar Machine Fluids Recommendations" (SEBU6250) for details.

**Engines with no aftertreatment devices can use higher blends, up to 100% biodiesel (for use of blends higher than 20% biodiesel, consult your Cat dealer).*

***Tailpipe greenhouse gas emissions from lower-carbon intensity fuels are essentially the same as traditional fuels.*

Air Conditioning System

- The air conditioning system on this machine contains the fluorinated greenhouse gas refrigerant R134a (Global Warming Potential = 1430). The system contains 0.85 kg (1.9 lb) of refrigerant which has a CO₂ equivalent of 1.216 metric tonnes (1.340 tons).

Paint

- Based on best available knowledge, the maximum allowable concentration, measured in parts per million (PPM), of the following heavy metals in paint are:
 - Barium < 0.01%
 - Cadmium < 0.01%
 - Chromium < 0.01%
 - Lead < 0.01%

Sound Performance

ISO 6395:2008 (external) 99 dB(A)

ISO 6396:2008 (inside cab) 68 dB(A)

- Hearing protection may be needed when operating with an open operator station and cab (when not properly maintained or doors/windows open) for extended periods or in a noisy environment.

Oils and Fluids

- Caterpillar factory fills with ethylene glycol coolants. Cat Diesel Engine Antifreeze/Coolant (DEAC) and Cat Extended Life Coolant (ELC) can be recycled. Consult your Cat dealer for more information.
- Cat Bio HYDO™ Advanced is an EU Ecolabel approved biodegradable hydraulic oil.
- Additional fluids are likely to be present, please consult the Operations and Maintenance Manual or the Application and Installation guide for complete fluid recommendations and maintenance intervals.

Features and Technology

- The following features and technology may contribute to fuel savings and/or carbon reduction. Features may vary. Consult your Cat dealer for details.
 - Advanced hydraulic systems balance power and efficiency
 - Smart mode matches machine power to digging requirements automatically
 - Eco mode supports reduced fuel consumption for light applications
 - One-touch low idle with automatic engine speed control
 - Increase operating efficiency with standard Cat technologies that help lower operator fatigue and operating costs.
 - Extended service intervals help decrease maintenance costs
 - Remote Flash and Remote Troubleshoot

Recycling

- The materials included in machines are categorized as below with approximate weight percentage. Because of variations of product configurations, the following values in the table may vary.

Material Type	Weight Percentage
Steel	82.77%
Iron	4.18%
Nonferrous Metal	1.88%
Mixed Metal	0.30%
Mixed-Metal and Nonmetal	2.50%
Plastic	0.16%
Rubber	3.30%
Mixed Nonmetallic	0.85%
Fluid	2.47%
Other	1.59%
Uncategorized	0.00%
Total	100%

- A machine with higher recyclability rate will ensure more efficient usage of valuable natural resources and enhance End-of-Life value of the product. According to ISO 16714:2008 (Earthmoving machinery – Recyclability and recoverability – Terminology and calculation method), recyclability rate is defined as percentage by mass (mass fraction in percent) of the new machine potentially able to be recycled, reused, or both.

All parts in the bill of material are first evaluated by component type based on a list of components defined by the ISO 16714:2008 and Japan CEMA (Construction Equipment Manufacturers Association) standards. Remaining parts are further evaluated for recyclability based on material type.

Because of variations of product configurations, the following value in the table may vary.

Recyclability – 95%

For more complete information on Cat products, dealer services, and industry solutions, visit us on the web at www.cat.com

© 2024 Caterpillar
All rights reserved

Materials and specifications are subject to change without notice. Featured machines in photos may include additional equipment. See your Cat dealer for available options.

CAT, CATERPILLAR, LET'S DO THE WORK, their respective logos, "Caterpillar Corporate Yellow," the "Power Edge" and Cat "Modern Hex" trade dress as well as corporate and product identity used herein, are trademarks of Caterpillar and may not be used without permission. VisionLink is a trademark of Caterpillar Inc., registered in the United States and in other countries.

AEXQ4094-00 (11-2024)
Build Number: 07H
(Europe, KSA, Türkiye)

